

**C21\_ Curriculum**

**DIPLOMA IN MECHANICAL ENGINEERING**



**OFFERED BY**

**STATE BOARD OF TECHNICAL EDUCATION & TRAINING,**

**TELANGANA: HYDERABAD**

### IV SEMESTER

	Course Code	Course Name	Teaching Scheme					Examination Scheme							
			Instruction periods per week			Total Periods per semester	Credits	Continuous internal Evaluation(CIE)			Semester end examination (SEE)		Total Marks	Min marks for passing including CIE	
			L	T	P			Mid Sem1	Mid Sem 2	Internal Evaluation	Max marks	Min marks			
1	SC-401	Advanced Engineering Mathematics	4	1	0	75	3	20	20	20	40	14	100	35	
2	ME-402	Design of Machine Elements	4	1	0	75	3	20	20	20	40	14	100	35	
3	ME-403	Heat Power Engineering	4	1	0	75	3	20	20	20	40	14	100	35	
4	ME-404	Advanced Manufacturing Technology	4	1	0	75	3	20	20	20	40	14	100	35	
5	EE-415	Basic Electrical Engineering	4	1	0	75	3	20	20	20	40	14	100	35	
6	ME-406	Production Drawing	1	0	2	45	1.5	20	20	20	40	20	100	50	
7	EE-417	Basic Electrical Engineering Lab	1	0	2	45	1.5	20	20	20	40	20	100	50	
8	ME-408	Thermal Engineering lab	1	0	2	45	1.5	20	20	20	40	20	100	50	
9	ME-409	Solid Modeling Lab													
10	HU-410	Employability Skills Lab	1	0	2	45	1.5	20	20	20	40	20	100	50	
11	ME-411	Skill Upgradation	0	0	8	120	2.5	0	0	<b>Rubrics</b>			--	-	
Activities: student performance is to be assessed through Rubrics															

## SC-401 - ADVANCED ENGINEERING MATHEMATICS

Course Title	Advanced Engineering Mathematics	Course Code	SC-401
SEMESTER	IV	Course Group	Foundation
Teaching Scheme in periods ( L : T : P )	4:1:0	Credits	3
Methodology	Lecture + Tutorial	Total Contact Periods	75
CIE	60 Marks	SEE	40 Marks

### Pre requisites:

This course requires the knowledge of Engineering Mathematics at Diploma first year level and Applied Engineering Mathematics at Diploma 3<sup>rd</sup> Semester level.

### Course Outcomes:

**At the end of the course, the student will have the ability to:**

CO 1	Solve simple Homogeneous Linear Differential Equations
CO 2	Solve simple Non-Homogeneous Linear Differential Equations and apply them in solving engineering problems.
CO 3	Express $f(x)$ as a Fourier series in the given interval $(c, c + 2\pi)$
CO 4	Express $f(x)$ as a Fourier Half-Range Cosine series and Sine series in $(0, \pi)$
CO 5	Find Laplace transforms of simple functions.
CO 6	Find Inverse Laplace transforms of simple functions and solve Linear Differential Equations using Laplace Transformations.

### Course Contents:

#### Unit – I

**Duration: 07 Periods (L: 5 – T: 2 )**

#### Homogeneous Linear Differential equations with constant coefficients

Homogenous linear differential equations with constant coefficients of order two and higher with emphasis on second order.

#### Unit – II

**Duration: 16 Periods (L: 13 – T: 3)**

#### Non-Homogeneous Linear Differential equations with constant coefficients

Non-homogenous linear differential equations with constant coefficients of the form  $(D)y = X$ , where  $X$  is in the form  $k(a \text{ constant}) e^{ax}$ ,  $\sin(ax)$ ,  $\cos(ax)$ ,  $x^n$ , ( $n= 1,2,3$ ) Complimentary Function (CF), Particular Integral (PI) and General Solution (GS).

### Unit-III

**Duration: 14 Periods (L: 11 – T: 3)**

#### Fourier series

Orthogonality of trigonometric functions, Representation of a function in Fourier series over the interval  $(c, c+2\pi)$ , Euler's formulae, sufficient conditions for existence of Fourier series for a function  $f(x)$ . Even, Odd functions and Fourier series over the Interval  $(0, 2\pi)$  and  $(-\pi, \pi)$

### Unit – IV

**Duration: 08 Periods (L: 7 – T:1 )**

#### Fourier Half-range series

Representation of a function  $f(x)$  as a Fourier Half-range Sine series and Cosine series over the interval  $(0, \pi)$

### Unit – V

**Duration: 14 Periods (L: 11 – T: 3)**

#### Laplace Transformations:

Definition, sufficient conditions for existence of Laplace Transform, Laplace Transform of elementary functions, linearity property, Change of scale property, First shifting theorem, multiplication by  $t^n$ , division by  $t$ , Laplace Transform of derivatives and integrals, unit step function, Laplace Transform of second shifting theorem

### Unit – VI

**Duration: 16 Periods (L: 13 – T: 3)**

#### Inverse Laplace transforms:

Inverse Laplace transforms- shifting theorems and change of scale property, multiplication by  $s^n$  and division by  $s$  – Inverse Laplace Transform using partial fractions – convolution theorem (no proof) – application of Laplace Transformations to solve ordinary differential equations of second order with initial conditions.

#### Recommended Books:

1. Higher Engineering Mathematics, B.S. Grewal.
2. Laplace Transforms - Murray R. Spiegel.
3. Ordinary Differential Equations – R. S. Aggarwal.
4. Fourier Series – A.R. Vasishtha and Gupta.

#### Suggested E-Learning references:

1. [www.freebookcentre.net/mathematics/introductory-mathematics-books.html](http://www.freebookcentre.net/mathematics/introductory-mathematics-books.html)
2. E-books:www.mathebook.net

#### Suggested Learning Outcomes

At the end of the course, the student will have the ability to:

### Unit-I

#### 1.0 Solve Homogeneous linear differential equations with constant coefficients in engineering situations

- 1.1 Solve Differential equations of the type  $(aD^2 + bD + c) y = 0$  when the roots of the Auxiliary Equation (A.E) are real & different, real & repeated and complex.
- 1.2 Solve the higher order homogeneous linear differential equations with constant coefficients.

### Unit-II

#### 2.0 Solve Non-Homogeneous linear differential equations with constant coefficients in engineering situations

- 2.1 Apply the concept of complementary function, particular Integral to get general solution of a differential equation.
- 2.2 Solve  $n^{\text{th}}$  order differential equation of the type  $f(D) y = X$  where  $f(D)$  is a polynomial of second order and  $X$  is a function of the form  $k, e^{ax}, \sin(ax), \cos(ax), x^n$ .
- 2.3 Solve simple problems on the above types of 2.2

### Unit-III

#### 3.0 Understand the Fourier series expansion of functions

- 3.1 Know the orthogonality of functions in an interval.
- 3.2 Identify Fourier series of a function in the interval  $(C, C+2\pi)$  and use the Euler's Formulae for determining the Fourier coefficients.
- 3.3 Write sufficient conditions for the existence of Fourier series for a function.
- 3.4 Expand Fourier series of simple functions in the range  $(0, 2\pi)$  and  $(-\pi, \pi)$ .
- 3.5 Expand Fourier series for even and odd functions in the interval  $(-\pi, \pi)$
- 3.6 Solve simple problems on even and odd functions in the interval  $(0, 2\pi)$  and  $(-\pi, \pi)$

### Unit- IV

#### 4.0 Understand the Half – Range Fourier series expansion of functions

- 4.1 Expand Half – Range Cosine series of a function in the range  $(0, \pi)$ .
- 4.2 Expand Half – Range Sine series of a function in the range  $(0, \pi)$ .
- 4.3 Solve simple problems on Half – Range Cosine and Sine series over the interval  $(0, \pi)$

## Unit-V

### 5.0 Understand Laplace transforms

- 5.1 Apply the definition of Laplace Transform and find Laplace transform of standard functions
- 5.2 Identify the sufficient conditions for existence of Laplace Transform.
- 5.3 Use the properties of Laplace Transform – Linearity property, First shifting theorem, Change of Scale property in solving simple problems.
- 5.4 Apply formulae for Laplace transform of  $t^n f(t)$ ,  $\frac{f(t)}{t}$ ,  $f^n(t)$ ,  $\int_0^t f(u)du$  in terms of Laplace transform of  $f(t)$  to solve simple problems
- 5.5 Identify unit step function and write the Laplace Transform of unit step function
- 5.6 Apply Second shifting theorem in solving simple problems.

## Unit-VI

### 6.0 Use Laplace transforms and Inverse Laplace transforms to solve differential equation in engineering problems

- 6.1 Define inverse Laplace Transform and write inverse Laplace Transforms of standard functions.
- 6.2 Solve simple problems on Inverse Laplace Transforms.
- 6.3 Write Shifting theorems and Change of scale property of inverse Laplace Transform.
- 6.4 Solve simple problems on 6.2
- 6.5 Write inverse Laplace Transforms corresponding to Laplace Transform of the functions  $t^n f(t)$ ,  $\frac{f(t)}{t}$ ,  $f^n(t)$ ,  $\int_0^t f(u)du$
- 6.6 Solve simple problems on 6.5
- 6.7 Define convolution of two functions and state convolution theorem.
- 6.8 Solve simple problems on Convolution theorem.
- 6.9 Use Laplace and inverse Laplace Transforms to solve simple differential equations of Second order.

### Suggested Student Activities:

1. Student visits Library to refer Standard Books on Mathematics and collect related material.
2. Quiz
3. Group discussion
4. Surprise tests

5. Seminars
6. Home Assignments.
7. Mathematics for preparing competitive exams and solving old question papers on Arithmetical ability.

**CO-PO Mapping Matrix**

CO	PO 1	PO 2	PO 3	PO 4	PO 5	PO 6	PO 7	Mapped POs
CO1	3	2					3	1,2, 7
CO2	3	2					3	1,2, 7
CO3	3	2					3	1,2, 7
CO4	3	2					3	1,2, 7
CO5	3	2					3	1,2, 7
CO6	3	2					3	1,2, 7

**QUESTION PAPER PATTERN FOR MID SEMESTER EXAMS**

**MID SEM-I EXAM**

S.No	Unit No	R	U	A	Remarks
1	Unit-I	1,2	5(a)	7(a)	
			5(b)	7(b)	
2	Unit-II	3,4	6(a)	8(a)	
			6(b)	8(b)	
Total Questions		4	4	4	

**MID SEM-II EXAM**

S.No	Unit No	R	U	A	Remarks
1	Unit-III	1,2	5(a)	7(a)	
			5(b)	7(b)	
2	Unit-IV	3,4	6(a)	8(a)	
			6(b)	8(b)	
Total Questions		4	4	4	

The length of answer for each question framed in respect of Part-A, B&C shall not exceed  $\frac{1}{4}$  of a page, 1 page and 2 pages respectively

Unit No	Questions to be set for SEE				
	R		U	A	
I	Q4	Q1	Q9(a)	Q13(a)	
II					
III		Q2	Q10(a)	Q14(a)	
IV					
V		Q3	Q5,Q6	Q9(b), Q11(a), Q11(b)	Q13(b), Q15(a), Q15(b)
VI			Q7,Q8	Q10(b), Q12(a), Q12(b)	Q14(b), Q16(a), Q16(b)
Total Questions		8	8	8	

**BOARD DIPLOMA EXAMINATIONS (C21)**  
**MID SEM –I, IV SEMESTER**  
**SC-401- ADVANCED ENGINEERING MATHEMATICS**

**TIME: 1: 00 Hour**

**Max. Marks: 20**

**PART-A**

Instructions: 1. Answer **ALL** questions 04 X 01 = 04

2 Each question carries **ONE** mark

1. Write the General solution of  $(aD^2+bD+c)y = 0$ , whose roots of auxiliary equation are real and distinct.
2. Find the roots of auxiliary equation of the differential equation  $(D^2 + 2D + 1)y = 0$
3. Find the Particular Integral of  $(D^2 - 4D + 1)y = e^{8x}$
4. Find the P.I of  $(D^2 - 9)y = \cos 3x$

**PART-B**

Instructions: 1. Answer **ALL** questions 02 X 03 = 06

2. Each question carries **THREE** marks

5 a) Solve  $(D^2 + 4D + 13)y = 0$

OR

5 b) Solve  $(D^2 + 16)y = 0$

6 a) Solve  $(D^2 + 4D + 4)y = 5 + e^{-2x}$

OR

6 b) Find P.I of  $(D^3 + D)y = \sin 2x$

**PART- C**

Instructions: 1. Answer **ALL** questions 02 X 05 = 10

2. Each question carries **FIVE** marks

7 a) Solve  $(D^3 - 2D^2 - 4D + 8)y = 0$

OR

7 b) Solve  $(D^3 - 6D^2 + 11D - 6)y = 0$

8 a) Solve  $(D^2 + 36)y = \sin^2 x$

OR

8 b) Solve :  $(D^2 - 3D + 2)y = x + x^2$





**BOARD DIPLOMA EXAMINATION, (C-21)**  
**IV SEMESTER END EXAMINATION**  
**SC-401- ADVANCED ENGINEERING MATHEMATICS**

Time: 2 hours

[Total Marks: 40]

**PART-A**

Instructions: 1. Answer **ALL** questions 08 X 01 = 08

2 Each question carries **ONE** mark

1. Find the roots of auxiliary equation of the differential equation  $(D^2 + 4D)y = 0$ .
2. Define Fourier Series for the function  $f(x)$  in the interval  $(c, c+2\pi)$
3. Find the Particular Integral of  $(D^2 - 4D + 1)y = e^x$
4. Find  $L(e^{2t} + \cos 3t)$
5. Find  $L(t + 5\cos ht)$
6. State the First Shifting theorem of Laplace Transforms.
7. Find  $L^{-1}\left(\frac{1}{s-3} + \frac{s}{s^2+4}\right)$
8. Find  $L^{-1}\left(\frac{1}{2s+5}\right)$

**PART-B**

Instructions: 1. Answer **ALL** questions 04 X 03 = 12

2. Each question carries **THREE** marks

9a) Solve  $(D^2 + D + 1)y = 4e^{3x}$

OR

9 b) Find  $L(t\cos 3t)$

10 a) Find Half Range Sine Series of  $f(x) = x$  in  $(0, \pi)$

OR

10 b) Find  $L^{-1}\left(\frac{s+1}{s^2+6s-7}\right)$

11 a) If  $L\{f(t)\} = \frac{20-4s}{s^2-4s+20}$ , find  $L\{f(3t)\}$

OR

11 b) Find  $\int_0^\infty t \cdot e^{-2t} \sin 3t dt$  using Laplace Transform Technique

12 a) Show that  $L^{-1}\left(\frac{1}{s(s^2+a^2)}\right) = \frac{1-\cos at}{a^2}$

OR

12 b) Find  $L^{-1}\left(\frac{s}{(s+2)^2+4}\right)$

**PART- C**

Instructions: 1. Answer **ALL** questions

04 X 05 = 20

2. Each question carries **FIVE** marks

13 a) Solve:  $(D^2 + D - 2) y = x + \sin x$

OR

13 b) Find  $L[te^t \sin 3t]$

14 a) Expand  $f(x) = x^2$  as a Fourier series in the interval  $(-\pi, \pi)$

OR

14 b) Find  $L^{-1}\left(\frac{s}{(s+1)^2(s^2+1)}\right)$

15 a) Find  $L\left(\frac{\sin 3t \cdot \cos t}{t}\right)$

OR

15 b) Evaluate  $L\left\{\int_0^t \frac{\sin t}{t} dt\right\}$

16 a) Find  $L^{-1}\left(\frac{1}{(s+1)(s+2)}\right)$  using Convolution theorem.

OR

16 b) Solve the differential equation  $y'' - 2y' - 8y = \sin t$ , when  $y(0) = 3$ ,  $y'(0) = 6$  by Laplace Transform method.

## ME-402-DESIGN OF MACHINE ELEMENTS

Course Title	Design of Machine Elements	Course Code	ME-402
SEMESTER	IV	Course Group	Core
Teaching Scheme in periods ( L : T : P )	4:1:0	Credits	3
Methodology	Lecture + Tutorial	Total Contact Periods	75
CIE	60 Marks	SEE	40 Marks

**Prerequisites:** Knowledge of solid mechanics

### COURSE OUTCOMES

	At the end of the course the student should be able to
CO1	Understand the concept of design procedure and to estimate the size of screwed fastener for given application.
CO2	Design of shafts to transmit the desired power and compare solid and hollow shafts for their strength and rigidity.
CO3	Design keys and couplings based on different modes of failure
CO4	Estimate the size of belt for a given power transmission and select a suitable gear train to transmit the desired velocity ratio.
CO5	Design sliding contact bearings and select a rolling contact bearing for given application.
CO6	State the applications of cams and construct their profiles.

### Blue Print of Marks for SEE:

Unit No	Unit Name	Periods	Questions to be set for SEE (QNo)				
			R	U	A		
1	A) Introduction B) Design of Of Bolts Nuts, Screws	13	4	1	9(a)	13(a)	
2	Shafts	12					
3	Keys and Couplings	12		2	10(a)	14(a)	
4	Belts and gear drives	13					
5	Bearings	12		3	5,6	9(b),11(a), 11(b)	13(b),15(a), 15(b)
6	Cams	13			7,8	10(b),12(a), 12(b)	14(b),16(a), 16(b)
Total		75		8	8	8	

**Legend: R; Remembering, U: Understanding A: Applying**  
**COURSE CONTENT**

**Duration: 13 Periods (L: 10.0 – T: 3.0)**

**1.A Introduction**

Design philosophy, Factors governing the design of machine element

Design procedure: General sequence of steps in designing a machine element.

Need of standard data for design purpose, use of machine design data, hand books and other data manuals.

**1.B Bolts, Nuts & Screws**

Thread nomenclature, specifications. Types of screw fasteners, Strength of screwed fasteners and failure due to different reasons Stresses due to initial tightening and external forces, Stress due to combination of forces

Design of a Nut – Hexagonal and square nuts only.

Design and draw an Eye bolt for a given load and using empirical proportions, Applications of eye-bolt and Numerical problems

**2. Shafts**

**Duration: 12 Periods (L: 10.0 – T: 2.0)**

Functions, Materials, Types

Standard sizes of shafts as per I.S

Design of diameters for solid and hollow shafts to transmit a given power at given rpm.

a) Based on strength

b) Based on rigidity.

Comparison of solid and hollow shafts, Design of axle, Numerical problems.

**3. Keys and Couplings**

**Duration: 12 Periods (L: 10.0 – T: 2.0)**

➤ **Keys**

Function of keys, types of keys, Splines, Specification of splines. Materials of keys and splines. Key failure, Effect of key way on the shaft strength. Design of a rectangular sunk key considering its failure against shear and crushing and using empirical proportions for given diameter of the shaft. Proportions of a spline for a given application using tables.

➤ **Couplings**

Function, types of couplings. Design and draw a muff coupling (solid) and rigid flange coupling for a given torque using empirical formulae.

**4. Belt and Gear Drives**

**Duration: 13 Periods (L: 10.0 – T: 3.0)**

Factors to be considered while selecting the type of drive -Belt drive, types of belt drives; belt materials, belt joints- length of open and crossed belts (without proof).

Slip and Creep-Expression for the ratio of belt tensions (without proof), Concept of centrifugal tension – Relation between centrifugal tension and the tension on tight side for transmitting maximum power (derivation omitted) - Permissible stress in the belt per unit width, per unit cross section-Calculation of belt thickness and width for given permissible stress for open and crossed belts.

Gear tooth terminology–Involute and Cycloidal profiles- advantages of involute profile-Gear Material-Simple, compound, reverted & Epi-cyclic gear trains-simple problems on gear terminology- number of teeth for simple, compound and reverted gear trains for a given speed ratio.

## 5. Bearings

**Duration: 12 Periods (L: 10.0 – T: 2.0)**

Functions, types of bearings, lubrication types, Journal bearing – terminology, performance - McKee's Equation, Bearing Modulus, power lost in friction and heat generated.

Thrust bearing- Torque equations for flat pivot and flat collar bearings under conditions of uniform pressure and uniform wear(without proof),Power lost in friction.

Rolling contact bearings – advantages and disadvantages-Components of rolling contact bearing, ball and roller bearings-types, applications-Rating life of antifriction bearing, Static load carrying capacity, Basic load rating, equivalent radial load - Load-Life relationship ( without derivations),

Market or commercial specifications of ball and roller bearings as per SKF and BIS standards

## 6. Cams

**Duration: 13 Periods (L: 10.0 – T: 3.0)**

Functions of cam - Classification of cams and followers – uses. Working principle of plate and cylindrical cams - Nomenclature of cam profile, base-circle, cam angles, trace point - Motion of follower – Uniform velocity, uniform acceleration and retardation and simple harmonic motion – angular displacement of cam or time vs. Displacement of follower diagram only - Construction of cam profile of a plate cam with knife edged, flat & roller follower for all three types of motions stated above - Problems on drawing of cam profiles as stated above for the follower axis passes through the axis of the cam shaft (offset followers not included).

## REFERENCES

1. Machine Design - Joseph Edward Shigley.
2. Machine Design - R.S.Khurmi & J.K. Gupta
3. Design of Machine Elements - Pandya and Shah.
4. Design of Machine Elements – V B Bhandari
5. Machine Design Data Handbook by H A Patil

## **ELECTRONIC RESOURCES**

1. <https://nptel.ac.in/courses/>
2. [An Online Mechanical Engineering Resource | The Engineer's Reference](#)
3. <https://www.slideshare.net/>
4. [Machine element - Wikipedia](#)
5. Course: Machine Design (iasri.res.in)

## **SUGGESTED LEARNING OUTCOMES**

*Upon completion of the course the student shall be able to*

### **1.A Introduction**

- 1.1. Understand the basic requirements of design.
- 1.2. Describe the phases of design process
- 1.3. List the factors governing the design.
- 1.4. Use of relevant Indian Standard Codes.

### **1.B Bolts, Nuts & Screws**

- 1.5. Explain screw thread nomenclature and specifications of screw threads
- 1.6. List the different threaded fasteners with legible sketches.
- 1.7. Explain the strength of screwed fasteners
- 1.8. List the stresses in bolts
- 1.9. Design the size of bolt for a given load
- 1.10. Design a Hexagonal and a Square Nut
- 1.11. Design the size of eye bolt for a given load.
- 1.12. Draw an eye bolt showing the proportions.

### **2. Shafts**

- 2.1. Define the terms shaft and axle
- 2.2. State the functions of shaft
- 2.3. List the types of shafts
- 2.4. List the standard sizes of shafts as per I.S
- 2.5. Write the formula for power transmitted by the shaft
- 2.6. Design the shaft subjected to only torsion
- 2.7. Design the shaft subjected to only bending load (Design of axle)
- 2.8. Design the shaft subjected to bending and torsion based on Rankine and Guest theories
- 2.9. Design the shaft against the rigidity.
- 2.10. Compare the strength and rigidity of solid and hollow shafts

### **3. Keys and Couplings**

- 3.1. Explain the types and function of keys and splines.
- 3.2. Name the recommended materials used for keys and splines.
- 3.3. Design the keys based on different modes of failure and also based on empirical relations
- 3.4. Write all the proportions of a spline for a given application referring tables.
- 3.5. Write the specifications of parallel, gib-head and taper sunk keys as per B.I.S.
- 3.6. Explain the function of a coupling
- 3.7. Classify the couplings
- 3.8. Design the muff coupling for a shaft of given Torque and using empirical relations.
- 3.9. Design the cast iron flange-coupling (rigid type) for a given torque
- 3.10. Draw the above couplings according to the standard specifications

### **4. Belt and Gear Drives**

- 4.1. List the different power drives.
- 4.2. Compare the flexible drives with the rigid drives
- 4.3. Classify the belt drives
- 4.4. List the belt materials
- 4.5. Define the slip and creep in belts.
- 4.6. Explain the effect of slip and creep on power transmission
- 4.7. Write the expression for the length of open and cross belts
- 4.8. Write the expression for ratio of belt tensions
- 4.9. Write the expression for centrifugal tension in the belt
- 4.10. Explain the effect of centrifugal tension on power transmission
- 4.11. Design the belt cross-sectional dimensions (V-belts are excluded)
- 4.12. Solve the numerical problems related to the above cases.
- 4.13. Explain the nomenclature of spur gear tooth.
- 4.14. Identify various tooth profiles of gear.
- 4.15. Advantages of involute profile
- 4.16. Explain the terminology related to gear drive
- 4.17. List the gear material
- 4.18. List different types of gear trains
- 4.19. List all the advantages and disadvantages of gear drives.
- 4.20. Explain different types of gear trains



4.21. Solve the simple problems related to gear terminology and gear trains.

## **5. Bearings**

- 5.1. State the function of bearing.
- 5.2. Classify the bearings—sliding and rolling contact.
- 5.3. State the advantages and disadvantages of sliding contact bearings
- 5.4. List the types of lubrication.
- 5.5. Explain the construction and working principle of journal bearing
- 5.6. Explain friction in journal bearing and give McKee's equation.
- 5.7. Explain the terms in McKee's equation.
- 5.8. Design a simple journal bearing.
- 5.9. Calculate heat generated and dissipated in journal bearing
- 5.10. Write the expressions for the load and torque carried by thrust and collar bearings under uniform pressure and wear conditions (without proof)
- 5.11. Calculate heat generated and dissipated in collar bearing based on uniform pressure and uniform wear conditions
- 5.12. Solve the numerical problems.
- 5.13. Explain the nomenclature of rolling contact bearing.
- 5.14. Explain the types of ball and roller bearings
- 5.15. List the Advantages and disadvantages of anti-friction bearings
- 5.16. List all the differences between sliding contact and roller bearings
- 5.17. Properties of the bearing material
- 5.18. Define the terms- Rating life, Basic load rating and equivalent radial load
- 5.19. Give the load – life relation for rolling contact bearings ( problems omitted )
- 5.20. Specify a bearing

## **6. Cams**

- 6.1. State the function of cam
- 6.2. Classify the cams.
- 6.3. Explain the cam profile.
- 6.4. Define terms related to cam profile.
- 6.5. Draw angular - displacement diagram for lift motion for:
  - a) Uniform velocity.
  - b) S.H.M.
  - c) Uniform acceleration & retardation.
- 6.6. Draw simple cam profiles in above three cases for knife edged, flat and roller followers. (Offset followers are omitted)

### **SUGGESTED STUDENT ACTIVITIES**

1. Student has to identify the machines and inspects the available equipment in the workshops/lab to identify different machine elements.
2. Identify the purpose of Gear trains used in automobiles, machine tools etc.
3. Draw the Involute and Cycloidal Gear tooth profile.
4. Recognise the need of cams and Draw the cam profiles
5. Collect the pictures and recoed videos of various types of machine elements which practically exist in machinery and automobiles.
6. Quiz & Group discussion, Surprise test.
7. Any Case studies- Example- Identifying any new ideas adopted for existing design.

<b>COURSE OUTCOMES</b>		<b>CL</b>	<b>Linked POs</b>	<b>Teaching Periods</b>
CO1	Understand the concept of design procedure and to estimate the size of screwed fastener for given application.	R, U, A	1,2,3,5,7	13
CO2	Design of shafts to transmit the desired power and compare solid and hollow shafts for their strength and rigidity.	R, U, A	1,2,3,7	12
CO3	Design keys and couplings based on different modes of failure	U, A	1,2,3,7	12
CO4	Estimate the size of belt for a given power transmission and select a suitable gear train to transmit the desired velocity ratio.	R, U, A	1,2,3,7	13
CO5	Design sliding contact bearings and select a rolling contact bearing for given application.	R, U, A	1,2,3,7	12
CO6	State the applications of cams and construct their profiles.	U, A	1,2,3,7	13
			<b>Total Periods</b>	<b>75</b>

**Legends: R = Remember; U= Understand; A= Apply and above levels (Bloom's revised taxonomy)**

### CO-PO Matrix

CO	PO1	PO2	PO3	PO4	PO5	PO6	PO7	Mapping Pos
CO1	3	2	2	-	1	-	1	1,2,3,5,7
CO2	2	3	3	-	-	-	1	1,2,3,7
CO3	2	3	3	-	-	-	1	1,2,3,7
CO4	2	3	2	-	-	-	1	1,2,3,7
CO5	2	3	2	-	-	-	1	1,2,3,7
CO6	1	2	2	-	-	-	1	1,2,3,7

Level 3- Highly Addressed, Level 2-Moderately Addressed, Level 1-Lowly Addressed .

### Course Content and Blue Print of Marks for MID - I

SL.NO	UNIT NAME	R	U	A	REMARKS
1	Introduction, Bolts, Nuts, Screws	1,2	5(a) 5(b)	7(a) 7(b)	
2	Shafts	3,4	6(a) 6(b)	8(a) 8(b)	
Total Questions		4	4	4	

### Course Content and Blue Print of Marks for MID – II

SL.NO	UNIT NAME	R	U	A	REMARKS
1	Keys, Couplings	1,2	5(a) 5(b)	7(a) 7(b)	
2	Belts and gear drives	3,4	6(a) 6(b)	8(a) 8(b)	
Total Questions		4	4	4	

Legend	Remembering (R)	1 Mark
	Understanding (U)	3 Marks
	Application (A)	5 Marks

**C21-MID-I Examination**  
**Model Paper-**  
**ME-402 DESIGN OF MACHINE ELEMENTS**

TIME : 1 Hour

Max. Marks: 20

PART – A

Marks: 04 X 1 M = 4M

*NOTE: 1) Answer All questions and each question carries one mark.*

*2) Answers should be brief and straight to the point*

1. Define Machine design.
2. Define pitch of screw thread.
3. What is the function of shaft.
4. Define Torsional stiffness of a shaft.

**PART – B**

**Answer all questions**

**2 x 3 M = 6M**

5(a). What are the factors to be considered for design of machine element. List out.

OR

5(b) Compute the safe tensile load for a bolt of M36 if the permissible tensile stress is 90 N/mm<sup>2</sup>

6(a) what are the advantages of Hollow shaft over solid shaft

(OR)

6(b). A hollow steel shaft has 200mm external diameter and 125 mm internal diameter. Shear stress at outer surface is 64 N/mm<sup>2</sup>. Calculate the shear stress at inner surface.

PART – C

**Answer all questions**

**2 x 05 = 10M**

7(a). An eye bolt is to be used for lifting a load of 100KN. Design the bolt, If the tensile stress is not to exceed 100 N/mm<sup>2</sup>.

(OR)

7(b). The cylinder head of steam engine is subjected to a pressure of 1 N/mm<sup>2</sup>. It is held in a position by means of 12 bolts. The effective diameter of cylinder is 300mm. A soft copper gasket (k=0.5) is used to make the joint leak proof. Determine the size of bolt so that the stress in bolt does not exceed 100MPa.

8(a) A solid circular shaft is used to transmit a torque of 9.6N-m.. The angle of twist over a length of 2m is 2°. Estimate the required diameter of the shaft and shear stress induced in the material. Take  $G = 0.8 \times 10^5$  N/mm<sup>2</sup>.

(OR)

8(b) A hollow shaft has 200mm external diameter and 125 mm internal diameter. Shear stress at outer surface is 64 N/mm<sup>2</sup>. Calculate the shear stress at inner surface.

**C21-MID –II Examination**  
**Model Paper**  
**ME-402 DESIGN OF MACHINE ELEMENTS**

TIME : 1 Hour

Max. Marks: 20

**PART – A**

Marks: 04 X1 M = 04M

*NOTE : 1) Answer All questions and each question carries one mark.  
2) Answers should be brief and straight to the point*

1. State the effect of keyway on the strength of a shaft.
2. What are splines.
3. Define creep of belt.
4. Define diametral pitch.

**PART – B**

**Answer all questions**

**2 x 3 M = 06M**

5(a) Draw the neat sketch of Gib Head Key with Proportions..  
(OR)

5(b) Write the differences between rigid couplings and flexible couplings.

6(a) State the advantages and disadvantages of belt drive over gear drive.  
(OR)

6(b) Explain the following terms (a) Circular pitch (b) Pitch circle.

**PART – C**

**Answer all questions**

**2 x 5 = 10M**

7 (a) Design a rectangular sunk key for a shaft of 60mm diameter. The permissible shear stress is  $35 \text{ N/mm}^2$  and compression stress is  $75 \text{ N/mm}^2$ .  
(OR)

7(b) Design a shaft and bolts for cast iron flange coupling to connect two shafts in order to transmit 9 kW at 800 rpm. The permissible shear and crushing stress for shaft and bolt material are  $35 \text{ N/mm}^2$  and  $60 \text{ N/mm}^2$ .

8 (a) A belt is required to transmit 15 KW from a pulley of 1000mm diameter at 420 rpm. The angle of lap is  $160^\circ$  and coefficient of friction is 0.3. If the safe working stress of belt material is  $1.2 \text{ N/mm}^2$ , find the width of belt. Thickness of belt is 10mm.  
(OR)

8 (b) Explain about compound gear train with a neat sketch

**BOARD DIPLOMA EXAMINATION**

**C21-End Semester Examination**

**Model Paper**

**ME-402 DESIGN OF MACHINE ELEMENTS**

TIME : 2 Hrs

Max. Marks: 40

**PART – A**

Marks: 08 X1 M = 08M

*NOTE : 1) Answer **All** questions and each question carries one marks.*

*2) Answers should be brief and straight to the point and shall not exceed **three** simple sentences*

1. Define machine design.
2. State the advantage of a leather as a belt material.
3. Define the term base circle.
4. What is the need for joining of shafts with couplings.
5. What is journal bearing.
6. Write the applications of bearings.
7. State three main parts of a cam mechanism.
8. List out the followers of cam.

**PART – B**

**Answer all questions**

4 x 3 M = 12M

9(a) What are the steps involved in design of a machine element.

(OR)

9(b) What is bearing . How are they classified.

10(a) A gear of 48 teeth has pitch circle diameter of 384mm. What is its module and circular pitch.

(OR)

10(b) What is a cam. List out types of cams.

11(a) what are equivalent static load and equivalent dynamic load.

(OR)

11(b) Write the advantages and disadvantages of sliding contact bearings.

12(a) Define the following

- (i) Lift or stroke
- (ii) Dwell

12(b) Write the information required to draw cam profile.

**PART-C**

4X5=20M

13(a) A solid shaft is subjected simultaneously to a torque of 28 KNm and bending moment of 22KNm. Find the diameter of shaft if the maximum shear stress is  $30 \text{ N/mm}^2$  and normal stress is  $50 \text{ N/mm}^2$ .

(OR)

13(b) A Flat collar bearing has internal and external diameter of 60 mm and 100 mm respectively and coefficient of friction is 0.05. Assuming the pressure is uniform at  $0.14 \text{ N/mm}^2$ . Calculate the power lost in friction at a speed of 5rev/sec.

14(a) The diameter of the pulley on the driving shaft running at 150 rpm is 0.6 m. A counter shaft is to be driven at 375rpm by an open belt drive, having a coefficient of friction 0.3. The distance between the shafts is 2.4m. Determine the width of the belt to transmit 3 KW, If the safe permissible tension is 15N/mm width of belt.

(OR)

14(b)What is displacement diagram. Explain the construction of displacement diagram for a follower moving with SHM.

15(a) A journal bearing 60mm in diameter and 90mm long runs at 450rpm. The oil used for hydrodynamic lubrication has absolute viscosity of  $0.016 \text{ kg/m.s}$ . If the diametral clearance is 0.1mm, find the safe load on bearing.

(OR)

15(b)A foot step bearing supports a shaft of 120mm diameter, running at 100rpm. The shaft is bored with a shallow hole of 40mm at the end. If the bearing pressure is  $0.75 \text{ N/mm}^2$ . Find (a) load to be supported and (b) power lost in friction if coefficient of friction is 0.015. (c) Heat generated.

16(a) A cam is to be designed for a knife edge follower with the following data:

1. Cam lift = 40 mm during  $90^\circ$  of cam rotation with simple harmonic motion.
2. Dwell for the next  $30^\circ$ .
3. During the next  $60^\circ$  of cam rotation, the follower returns to its original position with simple harmonic motion.
4. Dwell during the remaining  $180^\circ$ .

Draw the displacement diagram and profile of the cam when the line of stroke of the follower passes through the axis of the cam shaft.

The radius of the base circle of the cam is 40 mm.

(OR)

16 (b) Draw the profile of a cam to give the following motion to a reciprocating follower with a flat contact of face.

1. Out stroke during  $120^{\circ}$  of cam rotation
2. Dwell for the next  $30^{\circ}$  of cam rotation
3. Return stroke during  $120^{\circ}$  of cam rotation
4. Dwell for the remaining  $90^{\circ}$  of the cam rotation

The stroke of the follower is 30mm and the minimum radius of the cam is 25 mm. The follower moves with uniform velocity during both out stroke and return stroke. The axis of the follower passes through the axis of the cam shaft.



## ME-403-HEAT POWER ENGINEERING

Course Title	Heat Power Engineering	Course Code	ME-403
SEMESTER	IV	Course Group	Core
Teaching Scheme in periods ( L : T : P )	4:1:0	Credits	3
Methodology	Lecture + Tutorial	Total Contact Periods	75
CIE	60 Marks	SEE	40 Marks

### Prerequisites

Basic knowledge of Thermodynamics.

### Course outcomes

On Successful completion of the course, the student will be able to

CO1 :	Explain construction and working of Air compressors and gas turbines. Understand the working of jet and rocket engines.
CO2 :	Analyze properties of steam and estimate work done, enthalpy, internal energy entropy of steam using steam tables and Mollier chart
CO3 :	Distinguish between water-tube and fire-tube boilers and understand the construction and working of boilers and Boiler mountings & accessories
CO4 :	Explain working and design of steam nozzles for given conditions
CO5 :	Appraise working of steam turbines and distinguish between impulse and reaction turbines. Comprehend compounding and governing of turbines.
CO6	Analyze the construction and working of condensers and cooling towers.

**Blue Print of Marks for SEE**

Unit no	Unit name	Questions to be set for SEE (Q No)			Remarks		
		R	U	A			
1	Air Compressors, Gas Turbines & Jet Propulsion	4	1	9(a)	13(a)		
2	Properties of Steam		2				
3	Steam Boilers						
4	Steam Nozzles						
5	Steam Turbines		5,6		9(b)	13(b)	
					11(a)	15(a)	
6	Steam Condensers	7,8		11(b)	15(b)		
				10(b)	14(b)		
		3		12(a)	16(a)		
				12(b)	16(b)		
Total questions			8	8	8		

**Legend: R; Remembering, U: Understanding A: Applying**

## **COURSE CONTENT**

### **UNIT-1**

**Duration: Periods 14 (L: 11 – T: 03)**

#### **Air compressors, Gas Turbines & Jet Propulsion**

Functions of air compressor – uses of compressed air – types of air compressors - Single stage reciprocating air compressor its construction and working (with line diagram) using P.V. diagram. Formulae for work done and power required- simple problems on calculation of work done and power required. Multi stage compressors – advantages over single stage compressors. Use of inter cooler – conditions for minimum work in two stage compressor (without proof) Formulae for work done and power required in two stage compressors – simple problems. Gas turbines – Classification – open cycle gas turbines and closed cycle gas turbines – comparison of gas turbine with reciprocating I.C. engines and steam turbines. Applications, advantages and limitations of gas turbines- working of Open cycle constant pressure gas turbine – Closed cycle gas turbine – general lay-out. P.V. and T.S diagram. Principle of jet propulsion. Operation and applications of Ram – jet engine, turbojet engines and rocket engines – fuels used in jet propulsion.

### **UNIT-2**

**Duration: Periods 12 (L: 10 – T: 02)**

#### **Properties of steam**

Formation of steam under constant pressure- dryness fraction and degree of superheat - Determination of enthalpy, entropy and specific volume of wet, dry and superheated steam at a given pressure using steam tables and Mollier chart.

Vapour processes – isochoric, isobaric, isothermal, adiabatic and polytropic -simple problems on enthalpy, entropy and specific volume- internal energy, internal latent heat, of wet, dry and superheated steam using tables.

### **UNIT-3**

**Duration: Periods 12 (L: 09 – T: 03)**

#### **Steam Boilers**

Layout of steam power plant. Function and use of steam boilers – construction - Classification of steam boiler- Comparison of water tube and fire tube boilers - Cochran and Babcock Wilcox Boilers - modern high pressure boilers Lamont and Benson boilers - Boiler mountings - Boiler accessories - Actual evaporation - equivalent evaporation - factor of evaporation - boiler horse power - boiler efficiency - Formula for the above terms without proof - Simple direct problems on the above - draught systems

## UNIT-4

**Duration: Periods 12 (L: 10 – T: 02)**

### Steam Nozzles

Function – types- Flow of steam through nozzle - Velocity of steam at the exit of nozzle. Discharge of steam through nozzles - Critical pressure ratio - calculation of cross sectional areas at throat and discharge - Effect of friction in nozzles.

## UNIT-5

**Duration: Periods 13(L: 11 – T: 02)**

### Steam Turbines

Steam turbines - Classification - impulse & reaction turbines - working of a simple De-lavel turbine - Velocity diagrams of impulse turbines - Expression for work done, axial thrust, tangential force, blade and diagram efficiency, stage efficiency, nozzle efficiency – Compounding of turbines- velocity, pressure and combined pressure and velocity - Simple problems on single stage impulse turbines- analytical and graphical methods. Working of Parson's Reaction turbine -Bleeding, re-heating - regeneration and re- heating factor (Problems omitted) - Governing of steam turbines and methods.

## UNIT-6

**Duration: Periods 11 (L: 09– T: 02)**

### Steam Condensers

Steam condenser-Advantages of incorporating steam condenser in a power plant -Elements of a condensing unit -Classifications – Jet condenser -types of jet condenser -surface condenser -types of surface condenser Mixture of air&steam (Dalton's law of partial pressure ),Measurement of vacuum in a condenser , Vacuum efficiency ,Condenser efficiency, - Simple problems on Steam condensers - sources of Air leakage into condenser, effects of Air leakage, Wet-air extraction using Edwards Air pump, Cooling tower-types of cooling towers.

## REFERENCE BOOKS

1. Thermodynamics by Yunus Cengel
2. Thermal Engineering by Arora& S. Domkundwar
3. Thermodynamics and Heat Engines by R Yadav
4. Thermal Engineering by R.K Rajput
5. Thermal Engineering by R.S.Khurmi

### Suggested student activity

1. Students are advised to visit a nearby industry involving use of boiler and students are advised to conduct energy auditing.
2. Analyze the data by using excel and identify the areas of wastage of energy and suggest suitable methods for improvement of performance.
3. Velocity triangles of turbine may be solved using CAD software.
4. Visit nearest thermal power station and prepare a report consisting of layout – construction and working of various elements.

## **SUGGESTED LEARNING OUTCOMES**

Up on completion of the course the student shall be able to

### **1. Air compressors, Gas Turbines & Jet Propulsion**

- 1.1 State the functions of air compressors.
- 1.2 Enumerate the uses of compressed air.
- 1.3 Name the different types of compressors.
- 1.4 Explain with line diagram the working of a single reciprocating air compressor.
- 1.5 Write the formula for work done and power required by a single stage compressor.
- 1.6 State the advantages of multi- stage compressors over single stage compressor.
- 1.7 Explain the use of inter cooler.
- 1.8 State the conditions for minimum work done in two stage compression.
- 1.9 Solve simple problems on single acting reciprocating air compressors only.
- 1.10 Write the formula for work done and power required in two stage compressor.
- 1.11 Solve simple problems in two stage air compressor.
- 1.12 Classify gas turbines.
- 1.13 Compare Gas turbines with Steam turbines.
- 1.14 Compare gas turbines with reciprocating I.C. engines.
- 1.15 Mention the applications with limitations of gas turbine.
- 1.16 Explain with line diagrams the working of an open cycle constant pressure type gas turbine.
- 1.17 Explain with line diagram the working of a closed cycle type gas turbine.
- 1.18 Represent cycle of operation for the above type on P-V and T-s diagrams.
- 1.19 Explain with line diagram the principles of operation of Ramjet engine and turbo- jet and rocket engines.
- 1.20 Identify the fuels used in jet propulsion.

### **2. Properties of Steam**

- 2.1 Define the various properties and types of steam
- 2.2 Practice the use of steam tables and interpret the data for given pressure &Temp
- 2.3 Compute the enthalpy, specific volume and entropy at given pressure for wet, dry and superheated steam using steam tables.
- 2.4 Identify the various thermodynamic vapour processes isochoric,

isobaric, isothermal, adiabatic and polytropic.

2.5 Compute the work done, internal energy, enthalpy, specific volume and entropy in each of the above processes under wet, dry and superheated steam condition.

2.6 Represent the above process on T-S and H-S diagrams

### **3. Steam Boilers.**

3.1 State the function and construction of boiler

3.2 List all the uses of boilers.

3.3 Classify steam boilers

3.4 Distinguish between water tube and fire-tube boilers

3.5 Explain the working of Cochran Boiler with a legible sketch

3.6 Explain the working of Babcock Wilcox Boiler with a legible sketch

3.7 Recognize the need of high-pressure modern boilers

3.8 Explain the working principle of Lamont and Benson Boilers with a legible sketch

3.9 List all the boiler mountings

3.10 Explain the function of all the mountings with a legible sketch such as pressure gauge, water level indicator, safety valve and fusible plug.

3.11 List all the boiler accessories.

3.12 Illustrate the function of all the accessories with a legible sketch such as economiser, Super Heater, Steam traps & Separators.

3.13 Explain the terms actual/equivalent evaporation and factor of evaporation.

3.14 Define the boiler Power

3.15 Define the boiler efficiency

3.16 Write the formula for the above

3.17 Compute the equivalent and actual evaporation from given data.

3.18 Solve problems on Boiler Power & efficiency

3.19 Explain draught systems ( without problems )

### **4. Understand the Working of Steam Nozzles**

4.1 Explain the Flow of steam through nozzle

4.2 Derive the expression for Velocity of steam at the exit of nozzle in terms of heat drop.

- 4.3 Calculate Velocity of steam at the exit of nozzle by using steam tables or Mollier chart
- 4.4 Write the expression for Discharge of steam through nozzles
- 4.5 Write the formula for Critical pressure ratio ( without proof)
- 4.6 Explain the Effect of friction in nozzles
- 4.7 Solve problems of nozzles to calculate cross section area and discharge

## **5. Steam Turbines**

- 5.1 Explain the working principle and construction of a turbine
- 5.2 Classify the Turbines with examples
- 5.3 Differentiate the impulse turbines from reaction turbine
- 5.4 Explain the Principle of working of simple De-Laval turbine with a line diagram
- 5.5 Draw velocity triangles for impulse turbine
- 5.6 List various blade angles
- 5.7 Write formula for tangential force, work done, axial thrust, power and efficiencies.
- 5.8 State the necessity of compounding a turbine
- 5.9 Describe the methods of reducing rotor speeds by velocity, pressure and pressure- velocity compounding with the help of pressure, velocity variation chart
- 5.10 Explain the working principle of Parson's Reaction Turbine with a line diagram
- 5.11 Simple problems on Single Stage Impulse turbines (Velocity triangles and problems on reaction turbine omitted)
- 5.12 Define the terms bleeding & reheating
- 5.13 State the necessity of governing a turbine
- 5.14 Explain the methods of turbine governing

## **6. Steam Condensers**

- 6.1 Define the Steam condenser
- 6.2 State the functions of steam condenser
- 6.3 Classify the condensers
- 6.4 Explain the working principle of Low level counter – Flow and Parallel flow jet Condensers with legible sketch

- 6.5 Explain the working principle of High level Jet condenser with legible sketch
- 6.6 List the Advantages and Disadvantages of High- Level Jet condenser
- 6.7 Explain the working principle of Ejector condenser with legible sketch
- 6.8 Explain the working principle of Shell and Tube Surface condenser with sketch
- 6.9 Distinguish between down flow and central flow surface condenser
- 6.10 Explain the working principle of Evaporative condenser with legible sketch
- 6.11 List Advantages and Disadvantages of Surface condenser
- 6.12 Distinguish between Jet Condenser and Surface Condenser
- 6.13 Write the Formulae for cooling water required, Condenser efficiency, corrected Vacuum, absolute pressure and Vacuum efficiency
- 6.14 Solve Simple problems on Steam condensers to Estimate the Cooling water required, Condenser efficiency and Vacuum efficiency
- 6.15 Define Air Extraction
- 6.16 List the sources of air leakage into condenser.
- 6.17 State the effects of air leakage into condenser.
- 6.18 Explain the working principle of Edwards Air pump.
- 6.19 State the functions of Cooling towers.
- 6.20 Explain the working principle of natural ,forced and induced draught cooling towers.

**CO-PO Matrix**

CO	PO1	PO2	PO3	PO4	PO5	PO6	PO7	Mapping Pos
CO1	3	2	1	-	-	-	2	1,2,3,7
CO2	2	1	-	-	-	-	2	1,2,7
CO3	3	2	-	-	1	1	2	1,2,5, 6,7
CO4	3	2	1	-	-	1	3	1,2,3,6,7
CO5	3	2	1	-	-	1	2	1,2,3,6,7
CO6	1	1	1	-	-	-	2	1,2,3,7



### Continuous Internal Evaluation (CIE)

Test	Units	Marks
Mid Sem 1	1 and 2	20
Mid Sem 2	3 and 4	20
Slip Test 1	1 and 2	5
Slip Test 2	3 and 4	5
Assignments	-	5
Seminars	-	5
	Total	60

### QUESTION PAPER PATTERN FOR MID SEMESTER EXAMS

Sl.No	Description	Level	No.of Questions	Marks for each question	Questions to be attemptd	Total Marks
01	Part-A	Remembering(R)	4	1	Nil	4 Marks
02	Part-B	Understanding(U)	4	3	2	6 Marks
03	Part-C	Application(A)	4	5	2	10 Marks
Total Marks						20 Marks

### Question Paper Blue Print for CIE (MID I)

Unit no	Unit name	Questions to be set for MID-I			Remarks
		R	U	A	
1	Air Compressors, Gas Turbines & Jet Propulsion	1,2	5(a)	7(a)	
			5(b)	7(b)	
2	Properties of Steam	3,4	6(a)	8(a)	
			6(b)	8(b)	
Total questions		4	4	4	

### Question Paper Blue Print for CIE (MID II)

Unit no	Unit name	Questions to be set for MID-II			Remarks
		R	U	A	
3	Steam Boilers	1,2	5(a)	7(a)	
			5(b)	7(b)	
4	Steam Nozzles	3,4	6(a)	8(a)	
			6(b)	8(b)	
Total questions		4	4	4	

**State Board of Technical Education, Telangana State**  
**Model Paper**  
**ME-403 -HEAT POWER ENGINEERING**

**Mid Sem-I (CIE)**

**Time : 1 Hour**

**Total Marks : 20 M**

---

**PART – A**

**Marks: 4 X 1M = 4M**

*NOTE: 1) Answer ALL questions and each question carries One mark.  
2) Answers should be brief and straight to the point and shall not exceed three simple sentences*

1. Define air compressor.
2. Write the classification of gas turbines.
3. Define dryness fraction of steam.
4. Write the formula to find the enthalpy of wet steam.

**PART – B**

**Marks : 2 X 3M= 6 M**

*NOTE: 1) Answer ALL questions and each question carries Three marks  
2) The answers should be comprehensive and the criteria for valuation is the content but not the length of the answer.*

- 5.(a) Explain why volumetric efficiency decreases with increase in delivery pressure .  
(OR)
- 5.(b) differentiate between open cycle and closed cycle gas turbines.
- 6.(a) Calculate enthalpy, entropy of a steam at 2bar and 130<sup>0</sup>C temperature.  
(OR)
- 6.(b) represent a constant entropy process on mollier diagram.

**PART – C**

**Marks : 2 X 5M = 10 M**

**NOTE :**

*1) Answer ALL questions and each question carries Five marks.  
2) The answers should be comprehensive and the criteria for valuation is the content  
but not the length of the answer*

- 7.(a) explain the working of a two stage air compressor with the help of P-V diagram.  
(OR)
- 7.(b) explain the working of Ramjet with the help of a neat sketch.
- 8.(a) explain in detail the formation of steam under constant pressure.  
(OR)
- 8.(b) calculate the change in enthalpy of one kg of steam at 200<sup>0</sup> C and 3 bar pressure expanded to 0.3 bar pressure isentropically.

**State Board of Technical Education, Telangana State**  
**Model Paper**  
**ME-403 -HEAT POWER ENGINEERING**  
**Mid Sem-II (CIE)**

**Time : 1 Hour**

**Total Marks : 20**

**M**

**PART – A**

**Marks: 4 X 1M = 4M**

*NOTE: 1) Answer ALL questions and each question carries One mark.  
2) Answers should be brief and straight to the point and shall not exceed three simple sentences*

1. Mention any two boiler mountings.
2. Define equivalent evaporation.
3. Define nozzle.
4. List out different types of nozzles.

**PART – B**

**Marks : 2 X 3M= 6 M**

*NOTE: 1) Answer ALL questions and each question carries Three marks  
2) The answers should be comprehensive and the criteria for valuation is the content but not the length of the answer.*

5. (a) Write any three differences between fire tube and water tube boilers.

**(OR)**

5. (b) Write any three uses of steam boiler.

6. (a) Compute the critical pressure ratio in a nozzle when the steam is initially dry & saturated.

**(OR)**

6. (b) Write down the effect of friction in nozzles.

**PART – C**

**Marks : 2 X 5M = 10 M**

**NOTE :**

*1. Answer ALL questions and each question carries Five marks.  
2. The answers should be comprehensive and the criteria for valuation is the content but not the length of the answer*

7. (a) Explain the working of any water tube boiler with a neat sketch.

**(OR)**

7. (b) Define draught. Explain various methods of producing draught in steam boilers.

8. (a) Derive the equation for exit velocity of steam passing through a nozzle without friction.

**(OR)**

- 8 (b) Explain supersaturated flow of steam in nozzle.

**State Board of Technical Education, Telangana State SEE -Model Paper  
ME-403 -HEAT POWER ENGINEERING**

**Time : 2 Hour**

**Total Marks : 40 M**

---

**PART-A**

08X01=08

- Instructions** : 1. Answer **ALL** questions.  
2. Each question carries **ONE** mark.
1. Mention different fuels used in jet propulsion.
  2. List out the types of steam nozzles.
  3. Define condenser.
  4. Define dryness fraction of steam.
  5. Write the expression for work done in an impulse turbine.
  6. Define stage efficiency.
  7. Write the classification of condensers.
  8. Define vacuum efficiency w.r.t a condenser.

**PART-B**

04X03=12

- Instructions** : 1. Answer **ALL** questions.  
2. Each question carries **THREE** marks.
- 9(a) Write down the advantages of multi stage compression over single stage.
- (OR)**
9. (b) Write the differences between impulse and reaction turbines.  
10 (a) List out the classification of steam boilers.
- (OR)**
10. (b) Differentiate between surface and jet condensers.  
11. (a) Define the terms bleeding & reheating
- (OR)**
11. (b) Explain the working of a simple De-Laval turbine with a neat sketch.  
12. (a) Write a short note on shell and tube surface condensers.
- (OR)**
12. (b) List out the functions of a condenser.

**PART-C**

04X5=20

**Instructions** : 1. Answer **ALL** questions.

2. Each question carries **FIVE** marks.

13.(a) Explain the working of an open cycle constant pressure type gas turbine with the help of a neat sketch.

**(OR)**

13.(b) Explain different types of governing of steam turbines.

14.(a) Explain the working of Cochran boiler with a neat sketch.

**(OR)**

14.(b) Distinguish between dry air extraction and wet air extraction.

15.(a) Explain pressure compounding with the help of a neat sketch.

**(OR)**

15.(b) Numerical example

16.(a) Numerical example

**(OR)**

16. (b) Explain the working of steam jet air ejector with the help of a neat sketch

## ME-404-ADVANCED MANUFACTURING TECHNOLOGY

Course Title	Advanced Manufacturing Technology	Course Code	ME-404
SEMESTER	IV	Course Group	Core
Teaching Scheme in periods ( L : T : P )	4:1:0	Credits	3
Methodology	Lecture + Tutorial	Total Contact Periods	75
CIE	60 Marks	SEE	40 Marks

**Prerequisites:** Basic knowledge of Manufacturing Processes & Machine

### COURSE OUTCOMES

*On successful completion of the course, the students will be able to*

Course Outcomes	
CO1	Describe the construction and working of a turret lathe machines, Identify the Properties, composition of Cutting Fluids, Coolants & Lubricants to select depending on the application
CO2	Understand about Cores, moulding procedure, special casting methods and casting defects. Classify the advanced welding processes and requirement in various fields of engineering
CO3	Understand the concept of milling machine, types of milling machines, milling cutters
CO4	Illustrate the Working of Grinding Process and apply for engineering applications. Understand various surface finishing processes and apply for various applications
CO5	Explain Modern machining process for different applications.
CO6	Classify Press tools and apply it in various engineering applications & Identify Special tools for Work holding and guiding for different machining processes

## **COURSE CONTENT**

### **Unit – 1 PRODUCTION LATHES AND CUTTING FLUIDS**

**PERIODS: 12**

#### **Production Lathes and Cutting fluids**

Turret lathe: sketch – operation – advantages. Capstan lathe: sketch – operation – advantages. Comparison of engine (centre lathe) – turret – capstan lathe, Semi automatic lathe – features, Automatic lathe – features, Copying lathe – applications. Introduction, Types of cutting fluids. Properties and functions of fluids and coolants. Fluids and coolants required in turning, drilling, shaping, sawing & Broaching, Selection of cutting fluids, methods of application of cutting fluid. Classification of lubricants (solid, liquid, gaseous) Properties and applications of lubricants.

### **UNIT – 2: ADVANCED CASTING AND WELDING METHODS:**

**PERIODS: 13**

**Special Casting Processes:** Die casting- Hot chamber -Cold Chamber- Vacuum Die Casting, Permanent Mould (Gravity die) casting -Centrifugal casting - CO<sub>2</sub> process - Investment casting – continuous casting-squeeze casting, electro slag casting, Fettling and finishing, Advantages, Disadvantages and Applications

**Casting Defects:** Blow holes, Cold shuts and misruns, Hot tears, Mismatch, Shrinkage cavities, Fins or flash, Slag inclusions, Swell, Scabs, Warping- their causes and Remedies

**Advanced welding Methods:** - Introduction, Classification of advanced welding processes, Advantages and limitations of conventional welding - Working Principles of modern welding methods –Submerged - CO<sub>2</sub> - Atomic Hydrogen - ultrasonic welding - MIG & TIG Welding - Electro slag welding -plasma arc welding.

### **UNIT – 3 MILLING**

**PERIODS: 13**

**Milling :-** Purpose – Advantages and Classification -Column and knee type-plain-universal milling machine-vertical milling machine-specification of milling machines principles of operation-work and tool holding devices-arbor-stub arbor spring collet-adapter-milling cutters-cylindrical milling cutter-slitting cutter side milling cutter-angle milling cutter-T-slot milling cutter-woodruff milling cutter-fly cutter-nomenclature of cylindrical milling cutter-milling process conventional milling-climb milling-milling operations-straddle milling-gang milling-vertical milling attachment.

## **UNIT – 4 GRINDING AND FINISHING PROCESS**

**PERIODS: 12**

**Grinding** Introduction – principles of Metal Removal by Grinding-need of grinding – construction of grinding wheel - types of abrasives - need of bonding materials – types - binding processes: Vitrified, silicate, shellac, rubber, Bakelite , Factors effecting the selection of grind wheels – size and shape of wheel – effect of grain size ,grit, grade and strength of bond – structure of grain – spacing, Standard marking systems: Meaning of letters & numbers sequence of marking – Grades of letters. Grinding machines – classification: Cylindrical, Surface, Principle of centre less grinding, Advantages & limitations of centre less grinding- Work-holding devices - Dressing and trimming of grind wheels

**Other Finishing processes** Honing, Lapping, Super finishing, Electroplating–Basic principles – Plating metals – applications, Hot dipping: Galvanizing, Tin coating, Parkerising, Anodizing, Organic coatings: Oil base Paint, Lacquer base, Enamels, Bituminous paints, rubber base coating.

## **UNIT – 5 MODERN MACHINING PROCESS**

**PERIODS: 12**

Introduction – comparison with traditional machining; Ultrasonic Machining: principle, Description of equipment, applications - Electric Discharge Machining: Principle, Description of equipment, Dielectric fluid, tools (electrodes), Process parameters, Output characteristics, applications - Wire cut EDM: Principle, Description of equipment, Controlling parameters; applications - Abrasive Jet Machining: principle, description of equipment, application - Laser Beam Machining: principle, description of equipment, application - Electro Chemical Machining: description of equipment, application

## **UNIT – 6 PRESS TOOLS, JIGS & FIXTURES**

**PERIODS: 13**

**Press tools :-**Introduction - Types of Presses – hand, power, gap, inclinable, adjustable, horn, straight side, pillar presses - Constructional details of a power press-Press size. Press Tools – Punch and die- Die Accessories – Stops, Pilots, strippers, Knock outs, pressure pads.

Press working operations- blanking, piercing and forming, lancing, cutting off and parting, notching, shaving, trimming, embossing, beading and curling, bulging, twisting, coining, swaging, hole flanging or extruding –line sketches and meaning of terms - Types of dies meaning of inverted, progressive, compound and combination dies - Material selection for punch and die.

**Jigs & fixtures:-** Need and Applications of jigs & fixtures - Basic principles of location - Explain the locating methods and devices. Explanation of basic principles of the clamping - Types of clamps – strap clamps, cam clamps, screw clamps, toggle clamps, hydraulic and pneumatic clamps- Types of jigs - template jig, plate jig, leaf jig, box and handle jig, Indexing jig, Universal jig, vice jigs. Types of fixtures: milling & boring fixtures.



## **REFERENCE BOOKS**

1. Manufacturing Technology - P N Rao (MGH Publishers)
2. Production Technology - R.C.Patel
3. Production Technology - Jain & Gupta
4. Gear Technology - Charrathi
5. A Text Book of Production Engg. - Dora
6. Tool Design - Donaldson

## **SUGGESTED RESOURCES**

1. Grinding process  
<https://www.youtube.com/watch?v=Vcfau3bJ8hE>
2. Milling machine operation  
<https://www.youtube.com/watch?v=2jc3HkrHh9s>
3. Center less grinding  
[https://www.youtube.com/watch?v=LfbNFTyGW\\_c](https://www.youtube.com/watch?v=LfbNFTyGW_c)
4. Truing and dressing of a Grinding wheel  
<https://www.youtube.com/watch?v=GOR35qroeew>
5. Electroplating  
[https://www.youtube.com/watch?v=OxhCU\\_jBiOA](https://www.youtube.com/watch?v=OxhCU_jBiOA)
6. *Metal spraying*  
<https://www.youtube.com/watch?v=NAeBpF84Q9M>
7. ultrasonic machining process  
<https://www.youtube.com/watch?v=5w6szZtOg5w>
8. Wire cut EDM  
<https://www.youtube.com/watch?v=yNE0KZTDEsg>
9. *Injection moulding*  
<https://www.youtube.com/watch?v=b1U9W4iNDiQ>
10. Compression moulding  
<https://www.youtube.com/watch?v=pOGpXZ-UMfo>
11. *Transfer moulding*  
<https://www.youtube.com/watch?v=2DUB9DoIoi8>
12. Blow moulding  
<https://www.youtube.com/watch?v=8W6P5KU5ONQ>
13. Manual press  
<https://www.youtube.com/watch?v=nTshp3STG9M>
14. Hydraulic press  
<https://www.youtube.com/watch?v=JxJUPD-Ajnc>
15. Die and types  
<https://www.youtube.com/watch?v=qTuPkrfZB00>
16. Jigs and fixtures  
<https://www.youtube.com/watch?v=CA3GnfImGmw>

## **SUGGESTED STUDENT ACTIVITIES**

1. Student to inspect the available equipment in the lab to identify different machines, its functioning and application.
2. Quiz
3. Group discussion
4. Surprise test
5. Seminar

## **SUGGESTED LEARNING OUTCOMES**

*Upon completion of the course the student shall be able to*

### **1. PRODUCTION LATHES AND CUTTING FLUIDS**

- 1.1 List the various types of production lathes.
- 1.2 Illustrate the working principle, construction and working of turret lathe.
- 1.3 Understand the working principle, construction and working of Capstan lathes.
- 1.4 Know the working principle, construction and working of Automatic and Semi-Automatic Lathes.
- 1.5 Illustrate the working principle, construction and working of copying lathes.
- 1.6 Distinguish between automatic and semi-automatic lathes.
- 1.7 Explain the need of copying lathes.
- 1.8 State the advantages and applications of production lathes.
- 1.9 State the need and properties of cutting fluids and coolants.
- 1.10 Mention the types of fluids.
- 1.11 List the relative merits of the cutting fluids and coolants.
- 1.12 Select the proper cutting fluids and coolants for various machining operations.
- 1.13 Classify the lubricants.
- 1.14 List all the properties of lubricants.

### **2. ADVANCED CASTING & WELDING METHODS.**

- 2.1 Know the Advantages, disadvantages and Applications of die casting
- 2.2 Understand the working of hot chamber and cold chamber die casting,
- 2.3 Describe vacuum die casting
- 2.4 Explain permanent mould casting, centrifugal casting methods
- 2.5 Illustrate CO<sub>2</sub> process, investment casting their advantages and disadvantages
- 2.6 Know continuous casting-squeeze casting, electro slag casting,
- 2.7 Know finishing of casting Fettling
- 2.8 List and explain casting defects, reasons and remedies
- 2.9 List various advanced welding techniques its advantages and applications.
- 2.10 Explain the principle of MIG & TIG and related equipment
- 2.11 Explain the principle of Atomic hydrogen welding and related equipment.
- 2.12 Understand the principle of electron beam welding
- 2.13 Know the mechanism of CO<sub>2</sub> welding
- 2.14 List the various defects in welds.

### **3. MILLING**

- 3.1 List Types of milling machines.
- 3.2 Understand construction and working of column and knee type-plain milling machines
- 3.3 Know the construction and working universal milling machine
- 3.4 Illustrate the construction and working vertical milling machine
- 3.5 Give specification of milling machines
- 3.6 Identify work holding devices and their construction.
- 3.7 Identify tool holding devices and their construction.
- 3.8 Understand various milling cutters
- 3.9 Understand about Various Milling operations like cylindrical, face, End, profile
- 3.10 Understand construction and purpose of Milling cutters like -slitting cutter side milling cutter- angle milling cutter-T-slot milling cutter-woodruff milling cutter-fly cutter-
- 3.11 Understand about conventional milling-climb milling-milling operations-straddle milling-gang milling and vertical milling attachment.

### **4. GRINDING AND FINISHING OPERATIONS**

- 4.1 Understand the principle of metal removal by grinding.
- 4.2 List the different abrasives.
- 4.3 List and understand binding processes in grinding wheel manufacturing
- 4.4 Know the designation of grinding wheel
- 4.5 State the factors for selecting the grinding wheels.
- 4.6 Write the classification of grinding machines.
- 4.7 Understand the working and construction of Cylindrical grinding
- 4.8 Illustrate the working and construction of surface grinding
- 4.9 Understand the working and construction of tool and cutter grinders.
- 4.10 List the different work holding devices.
- 4.11 Understand finishing processes Honing, Lapping, Super finishing
- 4.12 Know the principle of electro-plating with a legible sketch.
- 4.13 Understand the principle of hot dipping processes namely galvanising, tin coating, Parkerizing and anodising.
- 4.14 List and understand the processes of various organic coatings.
- 4.15 State the principles of metal spraying.
- 4.16 Select the appropriate process for surface roughness of a given application

### **5. Modern machining process**

- 5.1 Compare modern machining process with traditional machining
- 5.2 Understand the principle, construction of Ultrasonic Machine and its applications.
- 5.3 Understand the principle of Electric Discharge Machining, Description of equipment
- 5.4 State the necessity of Dielectric fluid.
- 5.5 Identify the function of electrodes and its materials.
- 5.6 Give Process parameters, Output characteristics, of electrodes.
- 5.7 Understand the principle of Wire cut EDM, Description of equipment, Controlling parameters and give applications.

- 5.8 Understand the principle of Abrasive Jet Machining description of equipment, and give application.
- 5.9 Understand the principle of Laser Beam Machining, description of equipment, and give application.
- 5.10 Understand the principle of Electro Chemical Machining, description of equipment, and give application

## 6. **PRESS TOOLS, JIGS & FIXTURES**

- 6.1 Understand the Importance of Press Tools
- 6.2 Classify presses based on power and design of frame.
- 6.3 Understand the constructional details of a power press with the help of a legible sketch
- 6.4 State the meaning of Press size.
- 6.5 Know Press Tools – Punch and die.
- 6.6 Describe various press working operations.
- 6.7 Understand different types of dies.
- 6.8 List and explain various die operations
- 6.9 List punch and die materials
- 6.10 List types of jigs and explain their constructional details with the help of legible sketches
- 6.11 State general considerations in design of drill jigs
- 6.12 List different types of fixtures such as milling & boring fixtures and explain their constructional details with the help of legible sketches.
- 6.13 Differentiate between jigs and fixtures.
- 6.14 List the advantages of Jigs and Fixtures
- 6.15 Understand basic principle of location.
- 6.16 Identify different locating methods and devices.
- 6.17 Understand the basic principle of clamping.
- 6.18 Identify different types of clamps and their constructional details with the help of legible sketches

COURSE OUTCOMES		CL	Linked POs	Teaching Periods
CO1	Describe the construction and working of a turret lathe machines, Identify the Properties, composition of Cutting Fluids, Coolants & Lubricants to select depending on the application	R, U, A	1, 4, 7	13
CO2	Understand about Cores, moulding procedure, special casting methods and casting defects. Classify the advanced welding processes and requirement in various fields of engineering	R, U, A	1, 2, 4,5, 7	12
CO3	Understand the concept of milling machine, types of milling machines, milling cutters	U, A	1, 3,4,, 7	12
CO4	Illustrate the Working of Grinding Process and apply for engineering applications. Understand various surface finishing processes and apply for various applications	U, A	1, 3,4,, 7	13
CO5	Explain Modern machining process for different applications.	U, A	1, 2, 4,5,6, 7	12
CO6	Classify Press tools and apply it in various engineering applications & Identify Special tools for Work holding and guiding for different machining processes	R, U, A	1, 2, 3, 7	13
			<b>Total Periods</b>	<b>75</b>

**CO-PO Attainment Matrix:**

COURSE OUTCOMES	PROGRAM OUTCOMES						
	PO1	PO2	PO3	PO4	PO5	PO6	PO7
<b>CO1</b>	2	-	-	2	-	1	2
<b>CO2</b>	2	3	-	1	1	-	3
<b>CO3</b>	2	-	1	2	-	-	2
<b>CO4</b>	3	-	1	2	-	-	2
<b>CO5</b>	2	3	-	2	1	1	2
<b>CO6</b>	3	1	-	2	-	-	3

Level 3- Highly Addressed, Level 2-Moderately Addressed, Level 1-Lowly Addressed.

### MID SEM-I EXAM

S.No	Unit Name	R	U	A	Remarks
1	Production Lathes and Cutting fluids	1, 2	5(a)&(b)	7(a)&7(b)	
2	Advanced Casting and Welding methods	3, 4	6(a)&(b)	8(a)&8(b)	
<b>Total Questions</b>		4	4	4	

### MID SEM-II EXAM

S.No	Unit Name	R	U	A	Remarks
1	Milling	1, 2	5(a)&(b)	7(a)&7(b)	
2	Grinding & Finishing processes	3, 4	6(a)&(b)	8(a)&8(b)	
<b>Total Questions</b>		4	4	4	

### Blue Print of Marks for SEE:

Units		No of periods	Questions to be set for SEE			Remarks	
			R	U	A		
Part-A	Production Lathes and Cutting fluids	12	Q4	Q1	Q9(a)	Q13(a)	
	Advanced Casting and Welding methods	13					
Part-B	Milling	13		Q2	Q10(a)	Q14(a)	
	Grinding & Finishing processes	12					
Part-C	Modern machining process	12		Q3	Q5 Q6	Q9(b) Q11(a) Q11(b)	Q13(b) Q15(a) Q15(b)
	Press tools, jigs& fixtures	13					
<b>TOTAL</b>		<b>75</b>	<b>08</b>	<b>08</b>	<b>08</b>		

**MID SEM - I**  
**MODEL PAPER**  
**ME404 -ADVANCED MANUFACTURING TECHNOLOGY**

**Time:** 1 Hours

**Max. Marks:** 20

---

**PART-A**

4 X 1 = 4

**Instructions:** 1. Answer **ALL** questions.  
2. Each question carries **ONE** mark.

1. What is a turret lathe
2. What is the purpose of cutting fluids
3. Define centrifugal casting
4. What is meant by fettling

**PART-B**

2 X 3 = 6

**Instructions:** 1. Answer **ALL** questions.  
2. Each question carries **THREE** marks.

5. (a) List various production lathes  
OR
5. (b) State the advantages and applications of production lathes
6. (a) List various casting defects  
OR
6. (b) List the various welding defects

**PART-C**

2 X 5 = 10

**Instructions:** 1. Answer **ALL** questions.  
2. Each question carries **FIVE** marks.

7. (a) Explain Turret lathe  
OR
7. (b) Explain various types of cutting fluids
8. (a) Explain CO<sub>2</sub> welding  
OR
8. (b) Explain the principle of electro slag welding

**MID SEM - II**  
**MODEL PAPER**  
**ME404 -ADVANCED MANUFACTURING TECHNOLOGY**

Time: 1 Hours

Max. Marks: 20

**PART-A**

4 X 1 = 4

**Instructions:** 1. Answer **ALL** questions.  
 2. Each question carries **ONE** mark.

1. What is gang milling
2. What is a cutter
3. What is grit size
4. What is truing of grinding wheel

**PART-B**

2 X 3 = 6

**Instructions:** 1. Answer **ALL** questions.  
 2. Each question carries **THREE** marks.

5(a) List various Milling cutters

OR

5(b) What is Up milling

6(a) State the factors for selecting the grinding wheels.

OR

6(b) Write the specifications of a grinding wheel

**PART-C**

2 X 5 = 10

**Instructions:** 1. Answer **ALL** questions.  
 2. Each question carries **FIVE** marks.

7. (a) Explain Knee type milling machine

OR

7.(b) List various milling operations

8 .(a) Explain cylindrical grinding

OR

8.(b) Explain super finishing



**BOARD DIPLOMA EXAMINATION, (C-21)**  
**SEE-MODEL PAPER**  
**DME- IV SEMESTER EXAMINATION**  
**ME404 -ADVANCED MANUFACTURING TECHNOLOGY**

**Time:** 2 Hours

**Max. Marks:** 40

**PART-A**

8 X 1 = 8

**Instructions:** 1. Answer **ALL** questions.  
 2. Each question carries **ONE** mark.

1. What MIG welding
2. What is a abrasive material?
3. What is Parkerizing?
4. Define jig.
5. What is a dielectric fluid
6. Name the material used for electrode in EDM
7. Name any two types of jigs
8. What is a template jig?

**PART-B**

4 X 3 = 12

**Instructions:** 1. Answer **ALL** questions.  
 2. Each question carries **THREE** marks.

9(a). Compare MIG & TIG?

OR

9(b) Write the advantages of Modern machining process.

10(a). What is down milling?

OR

10(b). Compare jig & fixture.

11. (a) List the functions of a electrode in modern machining process..

OR

11. (b) List various electrode materials.

12(a). Explain progressive die with simple sketch.

OR

12(b). List various press work operations.

**PART-C**

4 X 5 = 20

**Instructions:** 1. Answer **ALL** questions.  
 2. Each question carries **FIVE** marks.

13 (a). Explain MIG welding.

OR

13 (b). Explain AJM

14 (a). Explain Vertical milling machine.

OR

14 (b) Explain a milling fixture

15 (a) Explain Ultrasonic machining

OR

15 (b) Explain ECM

16 (a) Explain about compound die

OR

16 (b) Explain the construction of box jig

## EE-415-BASIC ELECTRICAL ENGINEERING

Course title	Basic Electrical Engineering	Course code	EE-415
Semester	IV	Course group	Core
Teaching scheme in periods (L:T:P)	4:1:0	Credits	3
Methodology	Lecture+ Tutorial	Total Contact Periods	75
CIE	60 Marks	SEE	40 Marks

### Pre-Requisites

Enthusiasm to learn the course, the basic knowledge of Physics and Mathematics and particularly Electrical fundamentals at secondary school level.

### COURSE OUTCOMES

On successful completion of the course, the students will be able to

CO1	Understand the concepts of Basic electrical circuits, Electromagnetism and the Induced E.M.F.
CO2	Explain the construction and working of D.C.Machines.
CO3	Summarize the characteristics of A C waveforms, understand the concepts of single and poly phase circuits.
CO4	Explain the construction and working of A.C. Machines.
CO5	Explain the construction and working of Electrical Measuring instruments. Comprehend and follow Electrical Safety procedures and Protection aspects
CO6	Understand and explain the concept of PN junction diode, transistor configuration and types of logic gates.

## CONTENTS

**UNIT - I      Electrical Engineering Fundamentals      Duration: 13 Periods (L: 10 - T: 3)**

Definitions: Ohm's Law, Laws of resistance work, power, energy with units. Kirchoff's Laws. Electro – magnetic induction. Dynamically and statically induced e. m. f., Lenz's Law, Fleming's right hand rule, Inductance – self and mutual. Series and parallel circuits & simple problems.

**UNIT - II      D. C. Machines      Duration: 12 Periods (L: 9 - T: 3)**

D.C Generator: Principle of operation - Parts of generator - Types of generators - E.M.F equation - Power flow diagram -DC Motors : Principle of operation - Types of motors - Back e. m. f and speed equation - Starters and their necessity - Connection diagram of 3 point starter - Speed control – Field and Armature control - Applications of motors.

**UNIT - III      A. C. Fundamentals      Duration: 12 Periods (L: 9 - T: 3)**

Definition – alternating current, voltage amplitude, time period frequency, instantaneous value, Average value, R. M. S. value, form factor - Graphical representation of Alternating quantities - Phase difference - A.C. Circuits - Definition of poly-phase and 3- Ø circuits - Phase difference in 3-Ø - Star and delta connections, definitions of phase values and line values.

**UNIT - IV      A. C. Machines      Duration: 13 Periods (L: 10 - T: 3)**

Alternators – principle of working. Constructional features of alternators. Speed and frequency relations. Transformers working principle. Single phase transformers - Voltage ratio, Current ratio, Turns ratio - Welding transformer - 3-Phase Induction Motor - Working principle, Construction - Squirrel cage and Wound Rotor - Single phase Induction Motors - Types and applications of single phase induction motors.

**UNIT - V      Electrical measuring instruments & Safety procedures      Duration: 13 Periods (L: 10 - T: 3)**

Construction and principle of operation of PMMC & MI instrument - uses of multimeter- Single phase induction type Energy meter - Electrical safety Procedures - Effects of shock and burns - Remedial procedures to be adopted in case of electrical shocks - Plate earthing - Pipe earthing.

**UNIT - VI      Basic Electronics      Duration: 12 Periods (L: 9 - T: 3)**

Semi-conductors-N-type, P-type. Behaviour of PN junction diode. Introduction of PNP, NPN transistors. Transistor configuration – Zener diodes. Truth tables for OR, AND,NOT,NAND and NOR gates

## **SUGGESTED LEARNING OUTCOMES**

Upon completion of the course the student shall be able to

### **1.0 Basic Electrical Fundamentals.**

- 1.1 Define Voltage
- 1.2 Define Current
- 1.3 Define Ohm's Law.
- 1.4 Define Resistance.
- 1.5 State the Laws of Resistance.
- 1.6 Derive the expression for Resistance.
- 1.7 Define specific resistance
- 1.8 State Work, Power and Energy from electrical and mechanical aspects and understand their units.
- 1.9 Explain Kirchhoff's laws.
- 1.10 Define flux and flux density
- 1.11 State Faraday's laws of Electro Magnetic Induction.
- 1.12 Describe dynamically and statically induced E.M.F.
- 1.13 State Lenz's Law.
- 1.14 State Fleming's Right Hand rule.
- 1.15 Define self and mutual inductance.
- 1.16 Derive the expression for equivalent resistance in D.C Series circuit
- 1.17 Derive the expression for equivalent resistance in D.C Parallel circuit
- 1.18 Simple problems on Series and Parallel circuits

### **2.0 D C Machines.**

- 2.1 Explain working principle of D C Generators.
- 2.2 Know the constructional features of D C Generators and materials used.
- 2.3 List the types of D C Generators.
- 2.4 Write E.M.F equation of D C Generator
- 2.5 Solve substitution problems on emf equation.
- 2.6 Draw the power flow diagram of D C Generator.
- 2.7 List the different losses in DC generator
- 2.8 Explain working principle of D C Motor.
- 2.9 List types of D C motors.
- 2.10 Significance of back e.m.f in D C motor.
- 2.11 Write formula for speed of D C Motor in terms of supply voltage, current and flux.
- 2.12 List the different losses in DC motor
- 2.13 Write necessity of starters for D C motors.
- 2.14 Describe with sketch the connection diagram of a D C 3 point starter.
- 2.15 Explain the speed control of DC motor by a) Armature control, b) Field control method
- 2.16 List the applications of D C motors

### **3.0 A.C. Fundamentals**

- 3.1 Definitions: Alternating current, amplitude, time period, instantaneous value,
- 3.2 Define Average value, R.M.S value form factor, peak factor.
- 3.3 Graphical representation of alternating quantities
- 3.4 Know the concept of Phase and phase difference.

- 3.5 Define Power factor.
- 3.6 Write the formula for AC power.
- 3.7 Write the concept of Poly-phase and 3-phase system.
- 3.8 Comprehend Star and Delta connections.
- 3.9 Write the relation between Line and Phase values.
- 3.10 Solve simple conversion problems on line and phase values.

#### **4.0 A.C. Machines**

- 4.1 Explain working principle of alternators.
- 4.2 Constructional features of Alternators.
- 4.3 Know the frequency and speed relation in alternators.
- 4.4 State a transformer.
- 4.5 Explain the working principle of transformer.
- 4.6 Give the ratings of Transformer.
- 4.7 List the types of Transformers
- 4.8 Define Transformation ratio,
- 4.9 Give the relation between Transformation ratio, Voltage and Current ratios.
- 4.10 Describe the operation of a welding Transformer with sketch.
- 4.11 Explain the working Principle of 3-phase induction motor.
- 4.12 Construction of squirrel cage and wound rotors.
- 4.13 List the applications of 3-phase induction motors.
- 4.14 Describe the working principle of Single-phase induction motors.
- 4.15 List the types of 1-phase induction Motors.
- 4.16 Write the Applications of 1-phase induction Motors.

#### **5.0 Electrical Measuring Instruments and Safety Procedures.**

- 5.1 Explain the construction and working principle of permanent magnet Moving Coil instruments.
- 5.2 Explain the construction and working principle of Moving Iron instruments.
- 5.3 Compare PMMC and MI instruments
- 5.4 List the uses of multimeter
- 5.5 Explain the construction and working principle of 1-phase induction type energy meters.
- 5.6 State the list of wires and cables used for domestic wiring
- 5.7 List the different types of wiring systems
- 5.8 Explain Surface conduit wiring system
- 5.9 Explain Concealed wiring system.
- 5.10 List the various types of Main Switches
- 5.11 State the specifications of MCB
- 5.12 State the types of MCBs
- 5.13 State the applications of MCCB, ELCB and RCCB.
- 5.14 State the precautions to be taken to avoid electric shock.
- 5.15 Write the Effect of electrical shock.
- 5.16 Write the remedial procedures to be adopted in case of electric shocks.
- 5.17 Know the purpose of earthing of electrical equipment and machinery.
- 5.18 Describe the procedure of i) Pipe earthing and ii) Plate earthing.

## 6.0 Basic Electronics

- 6.1 Classify materials as conductor, semi-conductor and insulator.
- 6.2 Distinguish between intrinsic and extrinsic semiconductors.
- 6.3 Describe the formation of P type and N type materials.
- 6.4 Write the formation of P.N junction diode.
- 6.5 Explain the working of P.N junction diodes in forward bias and reverse bias.
- 6.6 Draw and explain characteristics of Diode in forward and reverse bias.
- 6.7 Explain the formation of NPN and PNP Transistor.
- 6.8 Draw the symbols of NPN and PNP transistors.
- 6.9 Understand the working of P.N.P and N.P.N transistors.
- 6.10 Draw the different transistor configuration (CB,CC AND CE).
- 6.11 Describe the operation of Zener diode.
- 6.12 Write the truth tables for OR, AND, NAND and NOR logic gates.

- a. **Note : Where ever mentioned, simple formula substitution problems only be solved and no problems in the other specific objectives.**

### SUGGESTED STUDENT ACTIVITIES

1. Student visits Library to refer to Manual of Electrical Safety.
2. Student inspects the available equipment in the Lab to identify the components
3. Quiz
4. Group discussions
5. Surprise test

### Suggested e-Resources:

1. [www.khanacademy.org](http://www.khanacademy.org)
2. [www.ocw.mit.edu/courses/electrical-engineering](http://www.ocw.mit.edu/courses/electrical-engineering)
3. [www.nptel.ac.in](http://www.nptel.ac.in)

### COURSE-PO ATTAINMENT MATRIX

CO's	PO1	PO2	PO3	PO4	PO5	PO6	PO7	Linked POs
CO1	2	1	-	1	-	-	1	1,2,4,7
CO2	2	-	-	2	1	-	1	1,4,5,7
CO3	2	1	-	1	-	-	1	1,2,4,7
CO4	2	1	-	2	1	-	1	1,2,4,5,7
CO5	2	-	-	2	2	-	2	1,4,5,7
CO6	2	-	-	1	-	-	1	1,4,7

**Level 3- Highly Addressed, Level 2-Moderately Addressed, Level 1-Low Addressed**

## Internal Evaluation

### QUESTION PAPER PATTERN FOR MID SEMESTER EXAMS

#### MID SEM-I EXAM

S.No	Unit No	R	U	A	Remarks
1	Unit-I	1,2	5(a)	7(a)	
			5(b)	7(b)	
2	Unit-II	3,4	6(a)	8(a)	
			6(b)	8(b)	
Total Questions		4	4	4	

#### MID SEM-II EXAM

S.No	Unit No	R	U	A	Remarks
1	Unit-III	1,2	5(a)	7(a)	
			5(b)	7(b)	
2	Unit-IV	3,4	6(a)	8(a)	
			6(b)	8(b)	
Total Questions		4	4	4	

The length of answer for each question framed in respect of Part-A, B&C shall not exceed  $\frac{1}{4}$  of a page, 1 page and 2 pages respectively

### QUESTION PAPER PATTERN FOR SEMESTER END EXAM

Unit No	Questions to be set for SEE				
	R		U	A	
I	4	1	9(a)	13(a)	
II					
III		2	10(a)	14(a)	
IV					
V		3	5, 6	9(b), 11(a), 11(b)	13(b), 15(a), 15(b)
VI					
Total Questions		8	8	8	

**BOARD DIPLOMA EXAMINATIONS**  
**Model Question paper**  
**DME IV semester Mid Semester-I Examination**

**Corse Code:EE-415**  
**Course Name:** Basic Electrical Engineering

**Duration:1 hour**  
**Max.Marks:20**

---

**PART – A**

**Marks: 4 X 1= 4**

**Instructions:** (1) Answer all questions  
(2) Each question carries **one** marks.

1. Define Ohm's Law.
2. Define specific resistance
3. Write the EMF equation of D.C. Generator
4. Write the classifications of D.C. Generators

**PART - B**

**Marks: 2 x 3 = 6**

**Instructions:** (1) Answer **all** questions.  
(2) Each question carries **three** marks.

5.(a) State the Laws of Resistance.

OR

5.(b) State Fleming's Right Hand rule.

6.(a) Write the types of D.C. Generator.

OR

6.(b) Draw the schematic diagram of D.C. Shunt Generator

**PART - C**

**Marks: 2 x**

**5= 10**

**Instructions:** (1) Answer **all** questions.  
(2) Each question carries **five** marks.

7.(a) State Faraday's laws of Electro Magnetic Induction.

OR

7.(b) Derive the expression for equivalent resistance in D.C Series circuit

8.(a) Draw power flow diagram of a D.C. Generator

OR

8.(b) Sketch the connection of welding generator.



**BOARD DIPLOMA EXAMINATIONS**  
**Model Question paper**  
**DME IV Semester Mid Semester-II Examination**

**Course Code:EE-415**  
**Course Name:** Basic Electrical Engineering

**Duration:1 hour**  
**Max.Marks:20**

**PART – A**

**Marks: 4 X 1= 4**

**Instructions:** (1) Answer all questions  
(2) Each question carries **one** marks.

1. Write the types of starters for D.C. motors
2. Write the classifications of D.C. motors
3. Define Time Period
4. Define R.M.S Value

**PART - B**

**Marks: 2 x 3 = 6**

**Instructions:** (1) Answer **all** questions.  
(2) Each question carries **three** marks.

- 5.(a). Draw the Schematic diagram of D.C. shunt motor.  
OR
- 5.(b). Write the types of speed control of D.C. motors.
- 6.(a). Define Phase and phase difference  
OR
- 6.(b). Draw the Star and Delta connections.

**PART - C**

**Marks: 2 x 5= 10**

**Instructions:** (1) Answer **all** questions.  
(2) Each question carries **five** marks.

- 7.(a). List any 4 applications of D.C. motors  
OR
- 7.(b). Explain the speed control of DC motor by Armature control method
- 8.(a). Write the relation between Line and Phase values in Star and Delta connection.  
OR
- 8.(b). Explain phase difference and Phase sequence in 3 phase system.

**BOARD DIPLOMA EXAMINATIONS**  
**DIPLOMA IN MECHANICAL ENGINEERING.**  
**SUB CODE: EE-415**  
Basic Electrical Engineering

**SEMESTER END EXAM MODEL PAPER**

**TIME: 2 HOURS**

**TOTAL MARKS: 40**

---

**PART – A**

**Marks : 8 X 1= 8**

**Instructions:** (1) Answer all questions  
(2) Each question carries **one** mark.

1. Define Flux.
2. State the transformer ratio.
3. List the uses of multimeter
4. Define Amplitude
5. List the various types of Main Switches
6. What is the instrument used to measure Power.
7. Draw the symbol of N.P.N transistor.
8. Write the truth tables for OR gate

**PART - B**

**Marks: 4 × 3= 12**

**Instructions:** (1) Answer all questions.  
(2) Each question carries **three** marks.

9.(a). State Faraday's laws of Electro Magnetic Induction.

OR

9.(b). Write the Effect of electrical shock.

10.(a). Write the relation between Line and Phase values in Star and Delta connection.

OR

10.(b). Explain the formation of N-type materials

11.(a). State the precautions to be taken to avoid electric shock.

OR

11.(b). State the list of wires and cables used for domestic wiring

12.(a). Distinguish between intrinsic and extrinsic semiconductors.

OR

12.(b). Explain the operation of Zener diode.

**PART – C**

**Marks: 4 × 5= 20**

- Instructions:** (1) Answer all questions.  
(2) Each question carries **five** marks.

13.(a). Draw power flow diagram of a D.C. Generator.

OR

13.(b). Explain the construction and working principle of Moving Iron instruments.

14.(a). Explain the working principle of 1-phase induction Motors.

OR

14.(b). Explain the working of PNP transistor.

15.(a). Describe the procedure of Pipe earthing.

OR

15.(b). Explain Surface conduit wiring system

16.(a). Explain the working of P.N junction diodes in forward.

OR

16.(b). Draw the different transistor configuration.

## ME-406-PRODUCTION DRAWING

Course Title	Production drawing	Course Code	ME-406
Semester	IV	Course Group	Practical
Teaching Scheme in Periods (L :T:P)	1:0:2	Credits	1.5
Methodology	Lecture + practice	Total Contact in Periods	45
CIE	60 Marks	SEE	40 Marks

**Prerequisites:** Basic knowledge of Assembly Drawing.

### Course Outcomes

	<b>At the end of the course the students will be able to :</b>
CO1	Understand the difference between machine drawing and production drawing. Understand the need and calculation of limits, fits and tolerances.
CO2	Understand the importance of surface roughness on life of component and its representation indicate surface roughness symbols in drawings, understand standard component specification.
CO3	Understand the Geometrical Tolerances indicated on production drawing and its symbols
CO4	Understand various reprographic methods
CO5	Illustrate production drawings of components, draw process sheet and apply suitable limits and fits.

### Course Content and Blue Print of Marks for SEE

Unit No	Unit Name	Periods	Questions for SEE		
			R	U	A
<b>PART-A</b>					
1	Introduction to production drawing, Limits, fits and tolerances.	06		1	
2	Geometrical Tolerances, Surface finish and standard mechanical component specifications. Reprographic Techniques	09		3	
<b>PART-B</b>					
3	<u>PART DRAWING EXERCISE – I</u> Gib and Cotter joint, Knuckle joint, Muff couplings, flange coupling universal coupling, Eccentric , stuffing box etc.. Process sheet preparation.	15			1
<b>PART-C</b>					
4	<u>PART DRAWING EXERCISE - II</u> Bearings (Foot step Bearing, Plummer block), Cross head, connecting rod, , lathe tail stock , Revolving centre , Non-return valve etc.	15			1
	Total	45			

**Part B each question carries 28 marks and distributed for**

- **Component drawing views..... 20 marks**
- **limits fits and tolerances..... 2 marks**
- **Geometrical tolerances..... 1 mark**
- **Surface finish..... 2 marks**
- **Process sheet ..... 3 marks**

**3. Standard components in part-B question need not be drawn.**

## **COURSE CONTENTS**

**1.0 Understand the idea of production drawing, Limits, Fit and Tolerances and Process sheet preparation**

**1.1 Introduction to production Drawing**

Need of preparing a production drawing, requirements for manufacturing a product like equipment, tools, measuring instruments depending upon processes, accuracy and finish data available in machine drawing – components of a production drawing, fits and tolerances, surface finish, specific processes, material of the component.

**a. Limits, fits and tolerances**

Concept of limits fits and tolerances – need of limits – standard designation of Hole and Shaft dimensions. Calculation of limits fits by using tolerance charts. Selecting dimensions from BIS standards to obtain clearance, transition and interference fits for a given set of mating parts – computation of fit and tolerance from BIS table. Exercises in computing tolerance.

**2.0 Geometrical tolerances to a component, Surface finish and Standard Mechanical component specification**

**2.1 Need of geometrical tolerances-** Types of geometrical tolerances - Tolerance of profile: profile of a line, surface.

Tolerance of orientation or attitude: angularity- perpendicularity- parallelism – flatness, cylindricity, circularity – Tolerance of location: position- concentricity- symmetry, Composite tolerances: radial run-out, axial run-out. Symbols for geometrical tolerances, indication of geometrical tolerances on components.

Exercises on representation of geometrical tolerances on the drawings

**2.2 Surface finish.** Indicate Profile of a surface and important characteristics of a surface, Identify the surface texture symbols. Identify Lay direction, surface roughness achievable from different manufacturing processes, Equivalent surface roughness symbols; Indicate the roughness values or grade number and corresponding symbol as per BIS. Indicate surface roughness on drawings.

- **Exercises** on specifying the surface roughness (average values) for functional surfaces of the following machine tool parts.
- -Shaft rotating in bush bearing,
- -Tailstock sleeve in tailstock body,
- -Keys and keyways
- -Mounting surfaces for antifriction bearings

- -Shaft or bush press fitted into bodies
- -Beds of machine tools, guide-ways
- -Contact surfaces ,example :flanges of pipe fittings
- -Peripheral surfaces of pulleys and grooves for v-belts
- -Surfaces of control elements example: levers ,hand wheels
- -Bases of machines
- -Machine tool tables

### **2.3 Standard Mechanical component specification.**

Standard components (parts) are to be designated as per BIS like - Bolts, Nuts, Locknuts ,Washers, Screws and, Studs – Circlips - Cylindrical and taper pins – Keys – Rivets – Splines - Oil seals-rings - Antifriction bearings:

### **3.0 Production drawing exercises-I**

Prepare the relevant views of the part(s) of a given assembly drawing needed for the purpose of production.

Dimension the views obtained and indicate on it with relevant notes the specific processes.

Compute/ identify the type fit between mating parts from ISI tables as per the function of the component and indicate the limits at appropriate place on the drawing prepared.

Indicate the geometrical tolerances on the component drawing

Mark the surface finish symbols with indications added.

Prepare the process sheet indicating sequence of processes and equipment, tools, measuring instruments required.

### **Production drawing exercises-I**

- Knuckle joint,
- Muff couplings,
- flange coupling
- universal coupling,
- stuffing box
- Eccentric

### **4.0 Production drawing exercises-II**

Prepare the relevant views of the part(s) of a given assembly drawing needed for the purpose of production.

Dimension the views obtained and indicate on it with relevant notes the specific processes.

Compute/ identify the type fit between mating parts from ISI tables as per the function of the component and indicate the limits at appropriate place on the drawing prepared.

Indicate the geometrical tolerances on the component drawing

Mark the surface finish symbols with indications added.

Prepare the process sheet indicating sequence of processes and equipment, tools, measuring instruments required.

### **Production drawing exercises-II**

- Foot step Bearing
- Plummer block
- cross Head,
- connecting rod,
- lathe tail stock ,
- Lathe tool post
- Revolving centre ,

### ***Student Activity***

Students/staff members advised to visit nearby local industry and collect actual production drawing, study and practise as exercise.

### **REFERENCE BOOKS**

1. IS 696 – 1972-Code of Practice for General Engg. Drawing & B.I.S Code – SP . 46. IS 696 – 1988
2. Machine Design date hand book – Vol I & II – Dr. K. Lingaiah, ( Suma Publishers, Bangalore).
3. IS Code on fits and tolerances.
4. Blur print reading for Mechanical Tradesby B.R.Sachdeva.
5. Machine drawing by R.B. Gupta.
6. Machine Drawing by Siddeswar.
7. Production Drawing by K.Venkat Reddy
8. Machine Drawing by Nagpal

### **SUGGESTED STUDENT LEARNING OUTCOMES.**

On the completion of the course the student should be able to

#### **1.0 Understand the need of production drawing and Interpret dimension to obtain Limits, fit and Tolerance as per BIS standards.**

- 1.1 Distinguish the machine drawing from a production drawing.
- 1.2 State the factors that govern the preparation of a production drawing.
- 1.3 Identify the components of a production drawing.
- 1.4 Identify various notations indicated on production drawing like Limits, fits, Tolerances, surface roughness symbols and Geometrical tolerances and its importance
- 1.5 State the need of Limits, allowance and tolerance

- 1.6 Definition of fit, allowance and tolerance.
- 1.7 Identify tolerance zones and tolerance grades
- 1.8 Classify types of fits, Material conditions, System of limits, specification tolerances
- 1.9 Selection of suitable fit for a given mating part.
- 1.10 Compute the fit from tables.
- 1.11 Indicate fits on the drawings.

**2.0 Geometrical Tolerances, Surface finish and standard mechanical component specifications and Reprographic Techniques**

- 2.1 Need of geometrical tolerances, Types of geometrical tolerances
- 2.2 Guidelines for indication of feature controlled by geometrical tolerances
- 2.3 Guidelines for indication of datum features, datum planes in space, General principles for applying geometrical tolerances on a component
- 2.4 Indicate Profile of a surface and important characteristics of a surface on drawings
- 2.5 Identify the surface texture symbols. Identify Lay direction, surface roughness achievable from different manufacturing processes, Equivalent surface roughness symbols.
- 2.6 Indicate the roughness values or grade number and corresponding symbol as per BIS.
- 2.7 Indicate the sequence of process of production.

**3.0 Illustrate the ability to draw the component views in exercise I**

**4.0 Illustrate the ability to draw the component views in exercise II**

**Course Content and Blue Print of Marks for Mid sem-I**

Unit No	Unit Name	Periods	Questions for SEE		
			R	U	A
<b>PART-A</b>					
1	Introduction to production drawing, Limits, fits and tolerances.	06		Q No.1,2	
2	Geometrical Tolerances, Surface finish and standard mechanical component specifications.	09		Q No.3,4,5 & 6	

**Course Content and Blue Print of Marks for Mid sem-II**

Unit No	Unit Name	Periods	Questions for SEE		
			R	U	A
<b>PART-B</b>					
3	<u>PART DRAWING EXERCISE – I</u> Gib and Cotter joint, Knuckle joint, Muff couplings, flange coupling universal coupling, Eccentric , stuffing box etc.. Process sheet preparation.	15			Q No. 1 & 2
	Total	15			



Course Outcome		Cognizant Level	Linked PO's
<b>CO1</b>	Understand the difference between machine drawing and production drawing. Understand the need and calculation of limits, fits and tolerances.	<b>R/U</b>	1, 4,7
<b>CO2</b>	Understand the importance of surface roughness on life of component and its representation, indicate surface roughness symbols in drawings, understand standard component specification.	<b>R / U</b>	1, 2, 3, 4, 7
<b>CO3</b>	Understand the Geometrical Tolerances indicated on production drawing and its symbols	<b>R / U</b>	1, 2, 3, 4,6,7
<b>CO4</b>	Understand various reprographic methods	<b>R / U / A</b>	1, 2, 3, 4,7
<b>CO5</b>	Illustrate production drawings of components, draw process sheet and apply suitable limits and fits.	<b>R / U / A</b>	1, 2, 3, 4,5,7

#### CO-PO Matrix

CO	PO 1	PO 2	PO 3	PO 4	PO 5	PO6	PO7
CO1	2	-	-	2	-	-	3
CO2	3	1	1	2	-	-	2
CO3	2	1	2	3	-	1	3
CO4	2	1	1	2	-	-	1
CO5	3	2	3	3	-	2	2

**BOARD DIPLOMA EXANIMATIONS**  
**CIE- MID-1Model Paper**  
**ME-406 -PRODUCTION DRAWING**

Time: 1 Hours

Max. Marks: 20

PART – A

04 X 05 M = 20M

- Instructions :**
1. Answer any **FOUR** questions.
  2. Each question carries **FIVE** marks.
  3. Answer should be neat & clear with all the necessary Dimensions.
  4. All Dimensions are in mm. Choose suitable Scale.
  5. Use of tolerance tables permitted.
1. The dimensions of a shaft and a hole are given  
Hole:  $35^{+0.022}_{+0.000}$  Shaft:  $\phi 35^{+0.031}_{+0.056}$  find out  
(a) Hole Tolerance (b) Shaft Tolerance (c) Min Allowance (d) Max allowance  
(e) Type of fit
2. The dimensions of a shaft and a hole are given 40Hg7  
(a) Hole Tolerance (b) Shaft Tolerance (c) Min Allowance (d) Max allowance  
(e) Type of fit
3. Draw the symbols of the following geometrical tolerances:  
a) Circularity b) Flatness c) Symmetry d) Misrun e) Parallelism
4. Indicate the roughness values for the following surface roughness grade numbers :  
(a)N 10(b)N 8 (c)N 6 (d) N 4 (e)N 1
5. Write the meaning of the following designations of mechanical components :  
(a) Square bolt M10 × 50 N  
(b) Ball bearing 308  
(c) Taper key 12 X 8 X 50  
(d) Fe 600 W  
(e) Splines 5 X 20 X 30
6. Draw the symbols of the following geometrical tolerances:  
a) Perpendicularity b) straightness c) concentricity d) angularity e) position



. Study the given assembly drawing of the protected flange coupling as shown in Figure given below:

- (a) Draw the component drawings of all except part 5----14M
- (b) Apply suitable geometric tolerances and fits.-----2M
- (c) Show the surface roughness symbols. -----1M
- (d) Draw the process sheet for flange -----3M

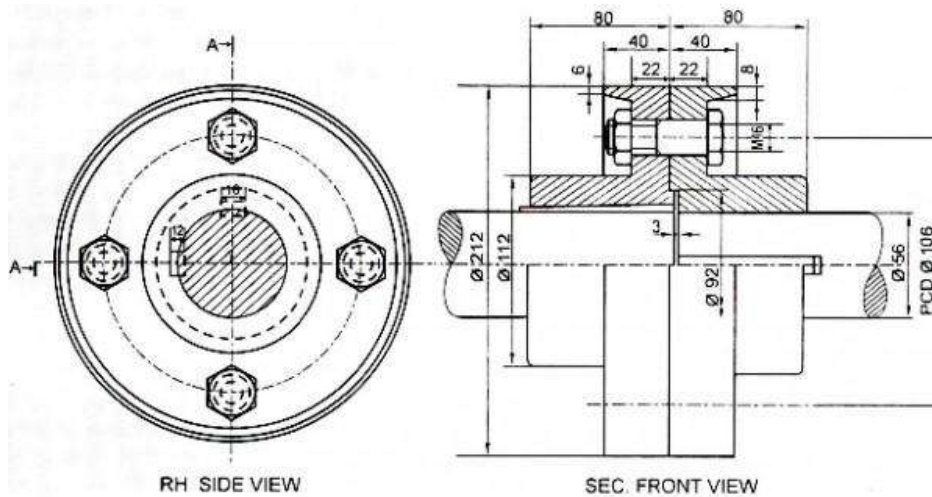

A PROTECTED FLANGE COUPLING

**BOARD DIPLOMA EXAMINATION**  
**MECHANICAL BRANCH –IV SEMESTER**  
**END EXAMINATION (SEE)**  
**ME-406 -PRODUCTION DRAWING**

Time: 2 Hours

[ Total Marks: 40]

---

**PART-A**

- Instructions:** 1. Answer all Questions **4X3=12 Marks**  
2. Each question carries **Three marks**.  
3. Answer should be neat & clear with all the necessary Dimensions  
4. All Dimensions are in mm. Choose suitable Scale

1. The dimensions of a hole and shaft are given below :

+0.039	+0.062
Hole : 30 +0.000	Shaft : 30 +0.041

Find (a) maximum allowance, (b) minimum allowance and (c) type of fit.

2. Write the meaning of the following designations of mechanical Components:  
(a) Hexagonal Bolt M20 × 60 (b) Bearing 100,10X26X8 (c) Taper key 12 X 8 X50v
3. Draw the symbols of the following geometrical tolerances:  
a) Perpendicularity.  
b) Cylindricity  
c) Angularity
4. Write the surface roughness values for the following :  
(a) Hot rolling  
(b) Cylindrical grinding  
(c) Lapping

## PART-B

### Instructions:

**1X28=28 Marks**

1. Answer any **one** Question
2. Each question carries 28 marks.
3. Answer should be neat & clear with all the necessary Dimensions
4. All Dimensions are in mm. Choose suitable Scale.

5. For the assembly drawing of Lathe tail stock and draw the component drawings indicating fits, roughness values and tolerances, write the process sheet for barrel

- Component drawing views..... 20 marks
- limits fits and tolerances..... 2 marks
  - Geometrical tolerances..... 1 mark
  - Surface finish..... 2 marks
  - Process sheet ..... 3 marks

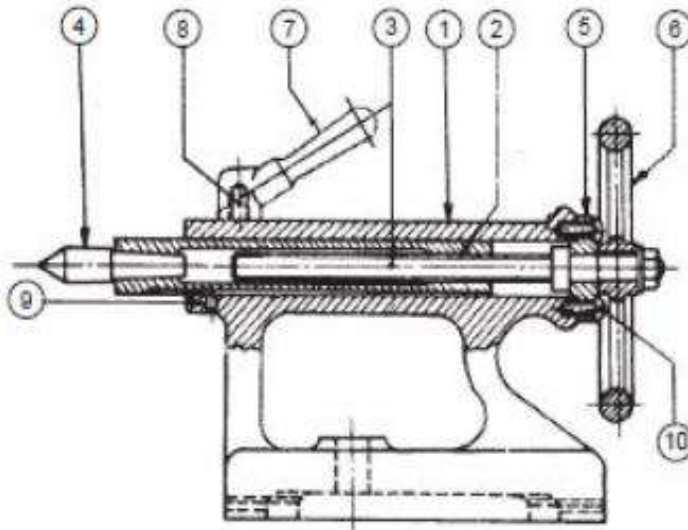

Fig. 18.18A Lathe tail-stock

Parts list

Part No.	Name	Matl	Qty
1	Body	CI	1
2	Barrel	MS	1
3	Spindle with washer & nut	MS	1
4	Centre	CS	1
5	Spindle bearing	CI	1
6	Hand wheel	CI	1
7	Clamping lever	MS	1
8	Stud	MS	1
9	Feather key	MS	1
10	Screw	MS	4

6. Draw the Component drawings of Plummer block with suitable tolerances and fits and write the process sheet for bolt  
 Component drawing views..... 20 marks

- limits fits and tolerances..... 2 marks
- Geometrical tolerances..... 1 mark
- Surface finish..... 2 marks
- Process sheet ..... 3 marks

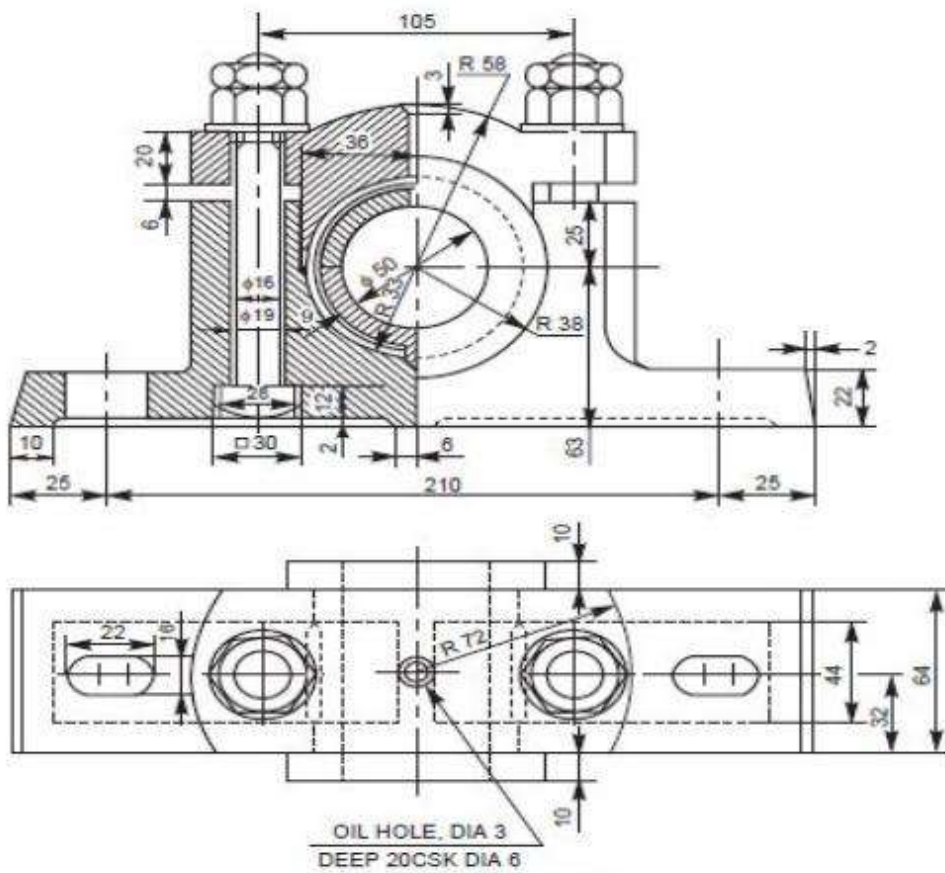

Fig. 12.4 Plummer block

### EE-417- BASIC ELECTRICAL ENGINEERING LAB

Course Title	Basic Electrical Engineering Lab	Course Code	EE-417
Semester	IV	Course Group	Practical
Teaching Scheme in Periods (L :T:P)	1:0:2	Credits	1.5
Methodology	Lecture + practice	Total Contact in Periods	45
CIE	60 Marks	SEE	40 Marks

#### Pre requisites

This course requires the basic skills of Handling Domestic tools, this course also requires the basic knowledge of basic mathematics at secondary school level.

#### Course Outcomes

On completion of course the student should be able to

CO1	Network Laws & Theorems
CO2	Calibration of meters
CO3	Measurement of Power
CO4	Speed control of D.C.Shunt motors
CO5	Earthing & Safety

Unit No	Unit name	Periods	Questions for SEE	Marks weightage	%of Weightage
			Handling/Manipulation/Precision		
1	Network Laws & Theorems	09	1	40	100
2	Calibration of meters	09	1		
3	Measurement of Power	09	1		
4	Speed control of D.C. Shunt motors	09	1		
5	Earthing & Safety	09	1		
Total		45	5	40	100

Note:

1. Student can answer any one question out of 5 questions.
2. To pass in practical Exam student should acquire 50% marks in both CIE and SEE separately and CIE & SEE put together.



Course Outcome (CO)		Cognizant Level	Linked Program Outcomes (PO)	Teaching periods
CO1	Network Laws & Theorems	R/U/A	1,2,3,4,7	5
CO2	Calibration of meters	R/U/A	1,2,3,4,6,7	6
CO3	Measurement of Power	R/U/A	1,2,3,4,6,7	11
CO4	Speed control of D.C. Shunt motors	R/U/A	1,2,3,4,6,7	12
CO5	Earthing & Safety	R/U/A	1,2,3,4,6,7	11
R: Remembering, U: Understanding, A: Applying				

### Suggested Learning Outcomes

1.0 Verify Network Laws

1.a Verify Ohm's Law

1.b Verify the limitations of Ohm's law using diode.

2. Verify Kirchoff's current Law

3. Verify Kirchoff's Voltage law

4. Verify Series and Parallel circuits by current and voltage division.

2.0 Calibrate the different meters

2.1 Calibrate Dynamometer type of wattmeter

2.2 Calibrate single phase Energy meter

3.0 Measure Power in DC and AC circuit

3.1 Measure power across a Resistor using voltmeter and ammeter when connected across a DC supply

3.2 Measure power and Power factor in 1 -  $\phi$  inductive circuit by using Wattmeter, Volt meter and Ammeter when connected across an AC supply

4.0 Perform Speed control of DC Shunt Motor

4.1. Armature / Rheostat control method

4.2. Field control method

5.0 Demonstrate domestic wiring circuits Earthing and Safety

5.1. Make a circuit for one lamp controlled by one switch with PVC surface conduit system.

5.2. Make a circuit for two lamps controlled by two switches with PVC surface conduit system.

- 5.3. Make a circuit for one lamp controlled by one switch and provision of 2/3pin socket.
- 5.4. Make a circuit for stair case wiring.
- 5.5. Make a circuit for godown wiring.
- 5.6. Make a circuit for electrical bell connection.
- 5.7. Make a circuit for ceiling fan with regulator
- 5.8. Make a circuit for series connection of lamps
- 5.9. Make a circuit for parallel connection of lamps
- 5.10. Control and practice the wiring for Fluorescent Lamp/LED Lamp
- 5.11. a) Demonstrate Pipe Earthing  
b) Demonstrate Plate Earthing
- 5.12. Demonstrate measurement of earth resistance using megger
- 5.13. Demonstrate the Procedure of first aid on Electric shock

### Safety Precautions

General Safety Precautions to be observed by the student for all Electrical laboratory Practices

1. Every student has to bring insulated tool kit and follow the general safety precautions throughout the lab sessions
2. Whenever handling/using a meter check for 'zero' position of the pointer and adjust for 'zero' position if there is any deviation

### CO-PO Mapping Matrix

CO	PO 1	PO 2	PO 3	PO 4	PO 5	PO6	PO7	Linked PO
CO1	3	1	-	-	2	2	3	1,2,5,6,7
CO2	3	-	2	3	2	2	3	1,3,4,6,7
CO3	-	1	3	2	2	2	3	2,3,4,5,6,7
CO4	-	3	3	3	2	2	3	2,3,4,5,6,7
CO5	3	2	3	3	2	2	3	1,2,3,4,6,7

### Competencies and key competencies to be achieved by the student

S. No	Experiment title	Competencies
<b>I (1a,b, 2,3)</b>	Verification of Network Laws & Theorems	<ul style="list-style-type: none"> <li>• Draw the relevant circuit diagram</li> <li>• Select proper supply and load.</li> <li>• Select proper meters with proper ranges</li> <li>• Select proper wires to make connections as per circuit diagram</li> <li>• Ensure that all the meters are connected with proper polarity</li> <li>• Perform the experiment by carefully following the experimental procedure and precautions</li> <li>• Observe the readings without any scope for errors and tabulate</li> </ul>
<b>II (4,5)</b>	Calibration of meters	<ul style="list-style-type: none"> <li>• Short M &amp; C terminals of wattmeter</li> <li>• Connect for proper Current range.</li> <li>• Calculate Multiplication factor</li> <li>• Calculate P, Error, %Error</li> <li>• Draw graph between W and % Error</li> </ul>
<b>III (6,7)</b>	Measure Power in DC and AC circuit	<ul style="list-style-type: none"> <li>• Select proper supply and load.</li> <li>• Select proper meters with proper ranges</li> <li>• Short M &amp; C Terminals of wattmeters and connect for proper current coil range</li> <li>• Find out the M.F of Wattmeter</li> <li>• Reverse wattmeter terminals for negative readings ( Lead values )</li> <li>• Calculate P, power factor(<math>\cos \phi</math>)</li> </ul>
<b>IV (8,9)</b>	Perform Speed control of DC Shunt Motor	<ul style="list-style-type: none"> <li>• Draw the relevant circuit diagram</li> <li>• Select the proper DC supply voltage</li> <li>• Choose the proper range of voltmeter, ammeter and rheostat.</li> <li>• Make the connections according to circuit diagram.</li> <li>• Ensure that all the instruments are connected in proper polarity</li> <li>• Keep the Rheostat connected to armature in maximum position in Rheostatic control method</li> <li>• Keep the Rheostat in field in minimum position in Field control method</li> <li>• Observe the speed variation with respect to</li> </ul>

<p><b>V</b> <b>(10)</b></p>	<p>Demonstrate Earthing</p>	<ul style="list-style-type: none"> <li>• . Draw Earthing diagram with specifications</li> <li>• Select suitable GI plate, GI wire and funnel with wire mesh</li> <li>• Prepare the earth pit of 1.5 m below the surface of the ground</li> <li>• Place Earth plate in vertical position</li> <li>• Draw GI wire to the GI pipe fastened to GI plate / copper plate with bolts &amp; nuts.</li> <li>• Pour sand, char coal and salt in alternate layers of about 15 cm around the earth pipe.</li> <li>• Test the earth resistance with Megger.</li> <li>• Verify the earth resistance.</li> </ul>
<p><b>(11)</b></p>	<p>Practice Safety Precautions.</p>	<ul style="list-style-type: none"> <li>• Practice the various first aid techniques.</li> <li>• Know the safety precautions.</li> </ul>

**BOARD DIPLOMA EXANIMATIONS, (C21)**

**MID I**

**Model Question paper**

**DME IV semester practical Examination**

**Corse Code: EE-417**

**Duration:1 hour**

**Course Name: Basic Electrical Engineering Lab**

**Max.Marks:20**

---

**Instructions to the Candidate:**

***(i) Answer any One of the following Questions.***

***(ii) Record the results on a graph sheet if required , and conclude your observation of the experiment***

***((iii) Draw the diagram for illustration; choose appropriate values when not mentioned in the question***

1. Verify Ohm's Law for given resistive circuit.
2. Verify the limitations of Ohm's law by using Diode
2. Verify Kirchoff's current Law
3. Verify Kirchoff's Voltage law
4. Verify in a parallel circuit the total current is equal to sum of Individual currents  
(  $I_{total} = I_1 + I_2$  )
5. Verify in a series circuit the total voltage is equal to sum of the voltage across the

each

Resistor (  $V_{total} = V_1 + V_2$  )

- 6 Calibrate Dynamometer type of wattmeter
- 7 Calibrate single phase Energy meter

**BOARD DIPLOMA EXANIMATIONS, (C21)**

**MID II**

**Model Question paper**

**DME IV semester practical Examination**

**Corse Code: EE-417**

**Duration:1 hour**

**Course Name: Basic Electrical Engineering Lab**

**Max.Marks:20**

-----  
----

**Instructions to the Candidate:**

***(i)Answer any One of the following Questions.***

***(ii)Record the results on a graph sheet if required , and conclude your observation of the experiment***

***((iii) Draw the diagram for illustration; choose appropriate values when not mentioned in the question***

1. Measure power across a Resistor using voltmeter and ammeter when connected across a DC supply
2. Measure power and Power factor in 1 -  $\phi$  inductive circuit by using Wattmeter, Volt meter and Ammeter when connected across an AC supply
3. Control the speed of a DC Motor by using Armature / Rheostatic control method
4. Control the speed of a DC Motor by using Field control method

**BOARD DIPLOMA EXANIMATIONS, (C21)**

**SEMESTER END EXAM**

**Model Question paper**

**DME IV Semester Practical Examination**

Corse Code: EE-417

Duration:3 hour

Course Name: Basic Electrical Engineering Lab

Max.Marks:40

-----  
----

**Instructions to the Candidate:**

*(i)Answer any One of the following Questions.*

*(ii)Record the results on a graph sheet if required , and conclude your observation of the experiment*

*((iii) Draw the diagram for illustration; choose appropriate values when not mentioned in the question*

1. Verify Ohm's Law for a restive circuit.
2. Verify the limitations of Ohm's law by using Diode
2. Verify Kirchoff's current Law
3. Verify Kirchoff's Voltage law
- 4 Calibrate given Dynamometer type of wattmeter
- 5 Calibrate given single phase Energy meter
6. Measure the power across a Resistor using voltmeter and ammeter when connected across a DC supply
7. Measure power and Power factor in 1 -  $\phi$  inductive circuit by using Wattmeter, Volt meter and Ammeter when connected across an AC supply
8. Control the speed of a DC Motor by using Armature / Rheostatic control method
- 9.Control the speed of a DC Motor by using Field control method.
- 10.Make a connection for one lamp controlled by one switch
- 11 Make a connection for one lamp controlled by TWO switches ( Stair case wiring)
- 12 Make a connection for two lamps controlled by two switches
- 13 Make a connection for ceiling fan with regulator
- 14 Make a connection for tube light (Fluorescent Lamp) with switch control
- 15.Draw and prepare Pipe Earthing
- 16.Draw and prepare Plate Earthing
17. Measure the resistance of given earth pit using megger
18. Write the Procedure of first aid on Electric shock

## ME-408-THERMAL ENGINEERING LAB

Course Title	Thermal Engineering Lab	Course Code	ME-408
Semester	IV	Course Group	Core
Teaching Scheme in Periods (L:T:P)	1:0:2	Credits	1.5
Methodology	Lecture + practice	Total Contact in Periods	45
CIE	60 Marks	SEE	40 Marks

**Prerequisites:** Basic knowledge of Thermodynamics

### Course OUTCOMES

*On successful completion of the course, the students will be able to*

Course Outcomes	
<b>CO1</b>	Evaluate and analyze economic speed of given IC Engine
<b>CO2</b>	Analyze water cooling curves on IC Engine
<b>CO3</b>	Calculate the power developed by multi cylinder engine using Morse Test
<b>CO4</b>	Understand the Performance Characteristics of given IC Engine
<b>CO5</b>	Estimate Heat Balance of Given IC engine
<b>CO6</b>	Understand working principle of Boiler

### LIST OF EXPERIMENTS

S.No.	Description	No of Periods
1	Economical Speed test on an I.C engine	6
2	Optimum cooling water flow and optimum cooling water temperature test on an IC engine	6
3	Morse Test on a 4-stroke multi cylinder I.C engine	6
4	Performance test on 2 stroke I.C engine	6
5	Performance test on 4 stroke I.C engine	6
6	Heat Balance Sheet of an I.C engine	9
7	Study of Boiler	6



## **SUGGESTED LEARNING OUTCOMES**

*Upon completion of the course the student shall be able to*

1. **Economic speed test on an IC Engine.**
  - 1.1. Identify various parts of an I.C engine
  - 1.2. Understand the working principles of an IC engine
  - 1.3. Understand the terms SFC ,Break power
  - 1.4. Calculate SFC, Break power for various load conditions.
  - 1.5. Plot graph SFC vs Speed
2. **Optimum cooling water flow and optimum cooling water temperature test**
  - 2.1 Identify various parts of an I.C engine
  - 2.2 Understand the working principles of an IC engine
  - 2.3 Understand the terms S.F.C, Break power
  - 2.4 Calculate SFC for respective engine jacket water flow rate
  - 2.5 Note engine jacket water outlet temperature
  - 2.6 Plot graphs SFC vs Engine jacket water flow rate, water outlet temperature
3. **Morse Test on a multi cylinder IC Engine**
  - 3.1 Identify various parts of an I.C engine
  - 3.2 Understand the working principles of an SI engine
  - 3.3 Understand the terms Friction power, engine efficiency
  - 3.4 Calculate friction power of the engine
4. **Performance test on IC engine.**
  - 4.1. Identify various parts of an I.C engine
  - 4.2. Understand the working principles of an IC engine
  - 4.3. Understand the terms Break power, S.F.C, Break thermal Efficiency
  - 4.4. Calculate Break power, S.F.C , Break thermal Efficiency
  - 4.5. Plot graphs B.P vs S.F.C, B.P vs Break thermal Efficiency
  - 4.6. Know the loading of IC Engine
  - 4.7. Know the application and usage of Tachometer
5. **Heat Balance sheet on an IC Engine.**
  - 5.1. Identify various parts of an I.C engine
  - 5.2. Understand the working principles of an IC engine
  - 5.3. Understand the terms Calorific value, specific heat Break power, S.F.C .
  - 5.4. Calculate heat lost to Break power, cooling water and exhaust gases.
  - 5.5. Tabulate heat balance sheet of given I.C engine

## 6. Study of Boilers

6.1. Identify various mountings and accessories of boilers.

6.2. Understand the working principle of fire-tube and water-tube boilers

6.3. Understand the terms Boiler horse power, Boiler efficiency

COURSE OUTCOMES		CL	Linked POs
CO1	Importance of economic speed of given IC Engine	R, U, A	1,2,3,4,7
CO2	Importance of optimum flow rate and temperature of cooling water in an IC Engine	R, U, A	1,2,3,4,6,7
CO3	Importance of Morse Test On Multi-Cylinder IC Engine	R, U, A	1,2,3,4,7
CO4	Importance of Performance Characteristics of given IC Engine	U, A	1,2,3,4,6,7
CO5	Importance of Heat Balance of Given IC engine	R, U, A	1,2,3,4,6,7
CO6	Study of boilers	R, U, A	1,4,7

**Legends: R = Remember; U= Understand; A= Apply and above levels (Bloom's revised taxonomy)**

### CO-PO Attainment Matrix:

COURSE OUTCOMES	PROGRAM OUTCOMES						
	PO1	PO2	PO3	PO4	PO5	PO6	PO7
CO1	2	3	1	1	-	-	3
CO2	3	2	1	2	-	1	3
CO3	2	2	1	2	-	-	3
CO4	3	1	2	2	-	1	3
CO5	3	3	2	2	-	1	3
CO6	2	-	-	1	-	-	3

Level 3- Highly Addressed, Level 2-Moderately Addressed, Level 1-Lowly Addressed.

**State Board of Technical Education, Telangana State**  
**Model Paper**  
**ME-408 – Thermal Engineering Lab**  
**Mid Sem-I (CIE)**

**Time : 1 Hour**

**Total Marks : 20 M**

---

**Note: Answer any one question.**

1. Find economical speed of IC engine.
2. Determine the variation of the fuel consumption, heat carried away by the cooling water and also find optimum temperature of cooling water at same load.
3. Determine the IHP and mechanical efficiency of IC engine
4. Conduct a test on IC engine and determine BP,FP and IP and mechanical efficiency.
5. Conduct a test on IC engine at constant speed and draw the performance curves.
6. Conduct a test on IC engine and prepare the Heat balance sheet.
7. Using a boiler evaluate relationship between pressure and temperature of saturated steam.

**State Board of Technical Education, Telangana State**  
**Model Paper**  
**ME-408 – Thermal Engineering Lab**  
**Mid Sem-II (CIE)**

**Time : 1 Hour**

**Total Marks : 20 M**

---

**Note: Answer any one question.**

1. Find economical speed of IC engine.
2. Determine the variation of the fuel consumption, heat carried away by the cooling water and also find optimum temperature cooling water at same load.
3. Determine the IHP and mechanical efficiency of IC engine
4. Conduct a test on IC engine and determine BP,FP&IP and mechanical efficiency.
5. Conduct a test on IC engine at constant speed and draw the performance curves.
6. Conduct a test on IC engine and prepare the Heat balance sheet.
7. Using a boiler the evaluate relationship between pressure and temperature of saturated steam.

**State Board of Technical Education, Telangana State**  
**SEE Model Paper**  
**ME-408 – Thermal Engineering Lab**

**Time : 2 Hour**

**Total Marks : 40 M**

---

**Note: Answer any one question.**

1. Find economical speed of IC engine.
2. Determine the variation of the fuel consumption, heat carried away by the cooling water and also find optimum temperature cooling water at same load.
3. Determine the IHP and mechanical efficiency of IC engine
4. Conduct a test on IC engine and determine BP,FP&IP and mechanical efficiency.
5. Conduct a test on IC engine at constant speed and draw the performance curves.
6. Conduct a test on IC engine and prepare the Heat balance sheet.
7. Using a boiler the evaluate relationship between pressure and temperature of saturated steam.

**ME-409-SOLID MODELING LAB**  
(Common to AU-308)

Course Title :	Solid Modeling Lab	Course Code	ME-409
Semester	IV	Course	Practical
Teaching Scheme in Periods(L:T:P)	1:0:2	Credits	1.5
Methodology	Lecture + Practical	Total Contact periods	45
CIE	60 Marks	SEE	40 Marks

**Pre requisites**

This course requires the basic knowledge of manufacturing process and Auto CAD

**COURSE OUTCOMES**

<b>At the end of the course the students will have the ability :</b>	
<b>CO 1</b>	List the commands of 3D
<b>CO2</b>	Create three-dimensional entities using different methods
<b>CO3</b>	Practice on Primitives with 3d Basics
<b>CO4</b>	Apply edit tools on Primitives
<b>CO5</b>	Apply the selection of material from library
<b>CO6</b>	Create the part drawing with a given geometry using Solid Modeling software

**COURSE CONTENT**

- **Viewing entities in three dimensions**
  - Setting a new viewing direction
  - Dynamically setting a view direction
- **Creation of three-dimensional entities using different methods**
  - Drawing of two dimensional entities in three dimensional space
  - Converting two dimensional planar entities into three dimensional entities by applying elevation and thickness
  - Converting two dimensional planar entities into three dimensional entities by revolving or extruding.
  - Creation of three-dimensional faces, rectangular meshes, ruled surface meshes, extruded surface meshes, revolved surface meshes, three dimensional entities

such as boxes, Cylinders, Cones, Spheres, wedges, torus, Regions, extruded solids, revolved solids, composite solids, intersect solids.

➤ **Editing in three dimensions**

Rotating in three dimensions, Array in three dimensions (Rectangular and polar)

Mirroring in three dimensions, Aligning in three dimensions

➤ **Editing of three dimensional solids**

Sectioning and Slicing of solids, hiding, shading and rendering

➤ **Selection of material from library**

Enable the material library, Editing materials and material library

➤ **The importance of Solid Modeling software like CREO/ SOLID EDGE/SOLID WORKS /**

Use any of the solid modelling packages stated above and generate a solid model of a machine component for different 3D components

**Suggested learning outcomes**

**Upon completion of the course the student shall be able to understand the concepts of 3D**

- View entities in three dimensions
- To set a new viewing direction
- To dynamically set a view direction
- **Create three-dimensional entities using different methods**
  - Draw two dimensional entities in three dimensional space
  - Convert two dimensional planar entities into three dimensional entities by applying elevation and thickness
  - Convert two dimensional planar entities into three dimensional entities by revolving or extruding.
  - Create three-dimensional faces
  - Create rectangular meshes
  - Create ruled surface meshes
  - Create extruded surface meshes
  - Create revolved surface meshes
  - Create three dimensional entities such as boxes, Cylinders, Cones, Spheres, wedges, torus, Regions,
  - Create extruded solids

- Create revolved solids
- Create composite solids
- Create intersect solids
- **Edit in three dimensions**
  - Rotate in three dimensions
  - Array in three dimensions (Rectangular and polar)
  - Mirror in three dimensions
  - Align in three dimensions
- **Edit three dimensional solids**
  - Practice Sectioning and Slicing solids
  - Practice hiding, shading and rendering
- **Practice the selection of material from library**
  - Enable material library
  - Edit materials and material library
  - Use any of the solid modelling packages stated above and generate a solid model of a machine component for different 3D components

<b>Exercise</b>	<b>Key components</b>	<b>Periods</b>
1.0 View entities in three dimensions	A. Set a new viewing direction B. Set dynamically view direction	<b>02</b>
2.0 Create three-dimensional entities	A. Create three-dimensional faces B. Create rectangular meshes, ruled surface meshes, extruded surface meshes, revolved surface meshes C. Create three dimensional entities such as boxes, Cylinders.	<b>18</b>
3.0 Edit in three dimensions	A. Rotate in three dimensions B. Array in three dimensions (Rectangular and polar) C. Mirror in three dimensions D. Align in three dimensions	<b>06</b>
4.0 Edit three dimensional solids	A. Practice Sectioning and Slicing solids B. Practice hiding, shading and rendering	<b>10</b>
5.0 Practice the selection of material from library	A. Enable material library B. Edit materials and material library	<b>03</b>
6.0 Appreciate the importance of Solid Modelling software like PRO-E / UNIGRAPHICS / CATIA	A. Use any of the solid modelling packages stated above and Generate a solid model of a machine component for different 3D components using Solid modelling packages	<b>06</b>
<b>Total</b>		<b>45</b>

CO	PO1	PO2	PO3	PO4	PO5	PO6	PO7
CO1	3	-	1	3	-	-	3
CO2	3	1	2	3	-	-	3
CO3	3	1	2	3	-	1	2
CO4	3	-	1	2	-	-	2
CO5	3	1	1	1	-	1	1
CO6	3	2	3	3	-	1	2

Course Outcomes		CL	Linked PO	Teaching Hours
CO1	Understand modeling software and List the commands of 3D	U/A	1,3,4,7	3
CO2	Create three-dimensional entities using different methods	U/A	1,2,3,4,7	12
CO3	Practice on Primitives with 3d Basics	U/A	1,2,3,4,6,7	6
CO4	Apply edit tools on Primitives	A	1,3,4,7	6
CO5	Apply the selection of material from library	U/A	1,2,3,4,6,7	3
CO6	Create the part drawing with a given geometry using Solid Modeling software	A	1,2,3,4,6,7	15

#### Course-PO Attainment Matrix

Course Name	Program Outcomes (PO)						
	1	2	3	4	5	6	7
Solid Modeling Lab	3	3	2	3	--	1	2
<b>Level 3- Highly Addressed, Level 2-Moderately Addressed, Level 1-Low Addressed</b>							



**ME-409- SOLID MODELING LAB  
MODEL PAPER FOR MID -1 (CIE)**

**TIME: 1hr**

**Marks: 20M**

NOTE: Answer any one of the following

**PART-A**

1. Create the below 2D drawing and dimension it using any solid modeling software.

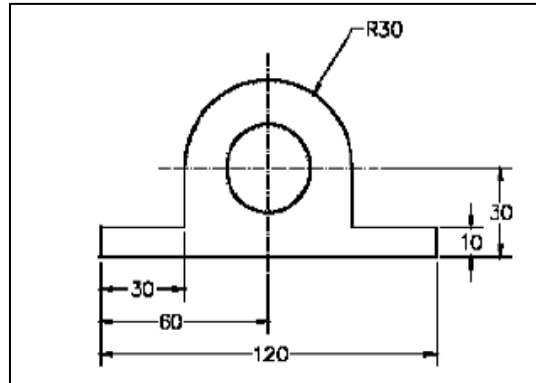

2. Create the below 2D drawing and dimension it using any solid modeling software.

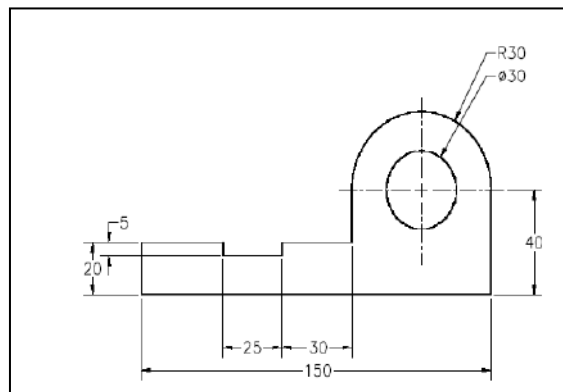

ME-409- SOLID MODELING LAB  
MODEL PAPER FOR MID -2 (CIE)

TIME: 1hr

Marks: 20M

NOTE: Answer any one of the following

1. Draw the following figure by using solid modeling software.

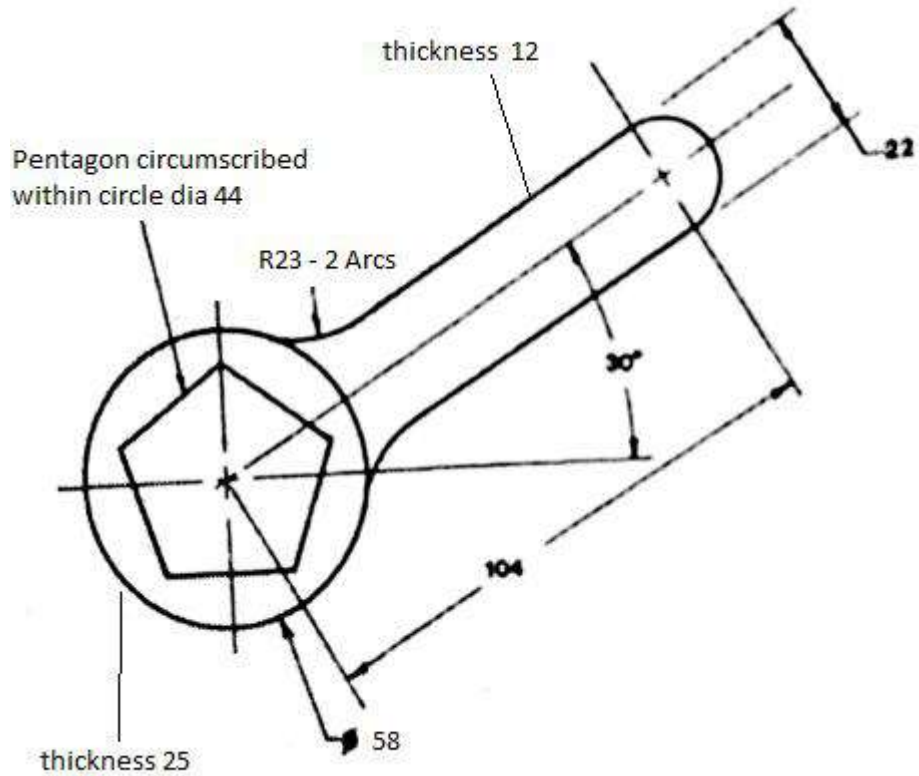

Note: All dimensions are in mm

2. Draw the following figure for thickness of 25mm by using solid modeling software.

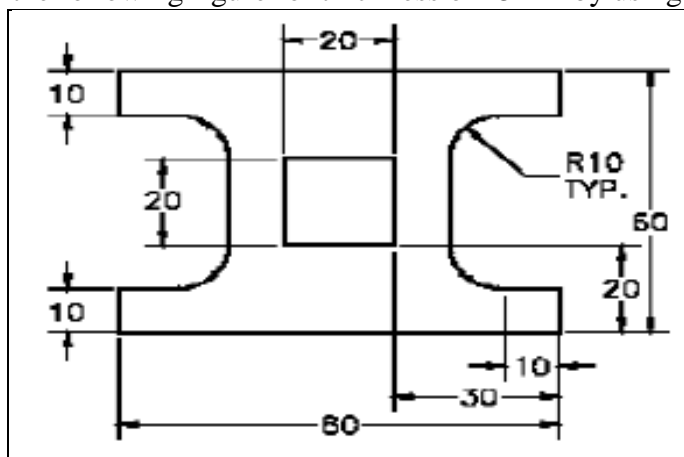

Note: All dimensions are in mm

**BOARD DIPLOMA EXAMINATION**  
**ME-409- SOLID MODELING LAB**  
**MODEL PAPER FOR SEE**

**Time: 02 Hour**

**Total Marks: 40**

Answer any ONE question.

**01×40=40 M**

3. 1. Draw the following figure by using solid modeling software.

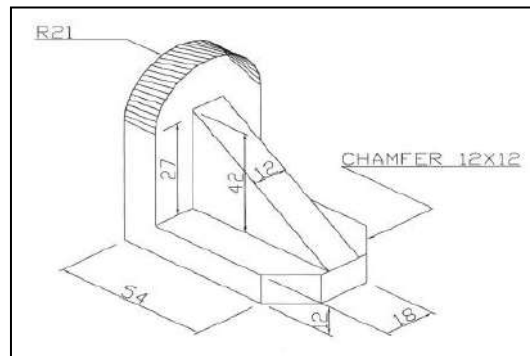
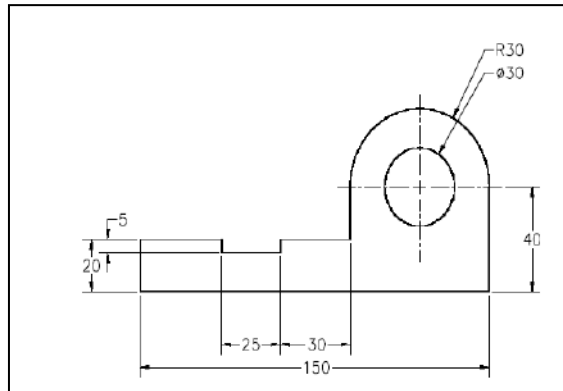

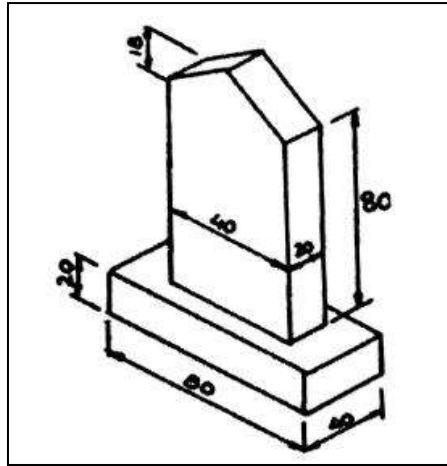

Marks breakup

1. Model creation – 25M
2. Viva – 10M
3. For writing answer – 5M

### **HU-410 – Employability Skills Lab**

Course Title	Employability Skills Lab	Course Code	HU-410
Semester	IV	Course Group	Core
Teaching Scheme in Hrs (L:T:P)	1:0:2	Credits	1.5
Methodology	Pair Work, Group Work, Activities, Lecture, Self-Learning	Total Contact Hours	45 (3 contact hours per week)
CIE	60 Marks	SEE	40 Marks

#### **Rationale:**

The course is designed to impart employability skills to make the students of diploma get the initial employment, maintain the employment and get better employment, if they wish.

#### **Prerequisites:**

The course requires the basic knowledge of vocabulary, grammar, four language learning skills, viz. listening, speaking, reading and writing and life skills.

#### **Course Outcomes**

CO1	Comprehend the importance of employability skills and strategies to survive in a job.
CO2	Converse fluently and accurately accordingly in JAM sessions. Group Discussions will enhance the willingness to take the Initiative, accept adaptability in turn developing leadership qualities and Communication Skills.
CO3	Understand purpose and process of interview in turn knowing how to prepare and succeed in interview.
CO4	Making effective presentation, Develop Public speaking skills and learn to make visually attractive PPTs.
CO5	Learn various writing formats useful at workplace and to develop an ability to apply technical information in documentation.
CO6	Build strong workplace relationships by learning workplace etiquette, professional ethics and importance of gender sensitization.

#### **Course Contents**

##### **Module 1: Introduction to Employability Skills**

**Duration: 6 Periods ( L 2 P 4 )**

- a. Filling the Curriculum gaps
  - i. Attributes and values
  - ii. Specific and general skills
  - iii. Academic Knowledge and Aptitude Skills
  - iv. Analytical skills / Data Analysis
- b. How to get into a job?
  - i. Good personal presentation and attitude
  - ii. Core generic skills
  - iii. Technical / Professional skills

- iv. Good Communication skills
- c. How to survive in a job?
  - i. Learning skills needed for self-advocacy and networking
  - ii. Adaptability to cope with the changing circumstances.
  - iii. Reliability and Integrity
  - iv. Continuous Learning and Consistency in performance.

**Module 2: JAM & Group Discussion**

**Duration: 9 Periods (L 3 P- 6)**

- i. What is JAM?
- ii. Significance of JAM
- iii. Enhancing Speaking skills, fluency, usage, coherence, spontaneity, voice modulation, eye contact, body language, Creativity, Sense of humor, Confidence and Time management.
- iv. Learn avoiding hesitation, deviation and repetition
- v. Purpose of Group Discussion
- vi. Types of Group Discussion
- vii. Different expressions and phases and their effective usage
  - a. Opinion expression agrees and disagrees, partially agree or disagree, interrupt politely, add new information and conclusion
- viii. Dos and Don'ts of a Group Discussion
- ix. Importance of body language, Etiquettes and awareness of group dynamics
- x. Practice.

**Module 3: Interview Skills**

**Duration: 9 Periods (L 3 P 6)**

- i. Importance of interview skills
- ii. Types of interviews
  - a) Face to Face / One to One, Telephonic / Video, Panel Interview.
- iii. Understanding the process of interview.
  - a) Before the interview
  - b) On the day of the interview
  - c) After the interview
- iv. FAQs, Common expressions of an interviewer and interviewee
- v. Acceptable and unacceptable gestures. Body language, and Attire,
- vi. Do's and Don'ts of an interview
- vii. Mock Interviews

**Module 4: Presentation Skills:**

**Duration: 9 Periods (L-3 P-6)**

- a) Significance of presentation
- b) Types of presentations.
  - i. Informative, Instructional, Arousing, Persuasive and Decision-Making
- c) . What makes a good presentation?
  - i. Understand, Collect, Organize, Use presentational aids and Practice

- d) Tips for an effective presentation
  - i. Good Beginning – Greeting, Confidence, Body Language, Opening Ideas (Funny Videos, Ridicule. Asking Questions, Quote someone/Proverb or telling a story/referring an historical event)
  - ii. Unveiling – Develop systematically, usage of appropriate linkers or discourse markers. Eye contact and Effective usage of PPTs
  - iii. Conclusion – Summarize - Giving time to the audience for queries and Time management
- e) Guidelines for PPTs
- f) Public Speaking Skills
  - i. Benefits – Personal and Professionals.
  - ii. Strategies to improve public speaking skills.
  - iii. Obstacles to effective public speaking.
  - iv. Overcoming the barriers of public speaking.
- g) Prepare presentation template.

#### **Module 5: Writing Skills at Workplace:**

**Duration: 6 Periods (L – 2 P – 4)**

- a) Various writing formats useful at workplace
- b) Skills involved in writing at workplace
- c) Different templates for different purposes
- d) Useful technical information in documentation

#### **Module 6: Workplace Awareness**

**Duration 6 Periods (L – 2 P – 4)**

- a) Workplace etiquette
- b) Knowledge, skills and attributes useful at workplace
- c) Workplace Relationships
- d) Professional ethics
- e) Importance of gender sensitization
- f) Sense of responsibility towards the society

#### **Suggested Student Activities:**

- Paper Presentations
- Seminars
- Mock Interviews
- Telephonic Interviews
- Group Discussions
- Role Plays
- Creating advertisements
- Five-minute activities
- Creating a model of workplace

### Course Outcomes

<b>CO1</b>	Comprehend the importance of employability skills and strategies to survive in a job.
<b>CO2</b>	Converse fluently and accurately accordingly in JAM sessions. Group Discussions will enhance the willingness to take the Initiative, accept adaptability in turn developing leadership qualities and Communication Skills
<b>CO3</b>	Understand purpose and process of interview in turn knowing how to prepare and succeed in interview.
<b>CO4</b>	Making effective presentation, develop public speaking skills and learn to make visually attractive PPTs.
<b>CO5</b>	Learn various writing formats useful at workplace and to develop an ability to apply technical information in documentation.
<b>CO6</b>	Build strong workplace relationships by learning workplace etiquette, professional ethics and importance of gender sensitization.

### CO-PO Matrix

<b>CO</b>	<b>PO1</b>	<b>PO2</b>	<b>PO3</b>	<b>PO4</b>	<b>PO5</b>	<b>PO6</b>	<b>PO7</b>	<b>Mapping POs</b>
<b>410.1</b>	-	-	-	-	3		3	5,7
<b>410.2</b>	-	-	-	-	3	2	3	5,6,7
<b>410.3</b>	-	-	-	-	3	3	3	5,6,7
<b>410.4</b>	-	-	-	-	2	2	3	5,6,7
<b>410.5</b>	-	-	-	-	2	2	3	5,6,7
<b>410.6</b>		-	--	--	2		3	5,7



## **Evaluation Pattern:**

### **I. Continuous Internal Examination: 60 Marks**

- a. **Mid Sem - I** 20 marks  
Syllabus:  
i. Introduction to Employability skills  
ii. JAM & Group Discussion
- b. **Mid – II** 20 Marks  
Syllabus:  
i. Interview Skills  
ii. Presentation skills
- c. **Internal assessment** 20 marks
- i. Seminars: 10 marks  
ii. Assignments: 5 marks  
iii. Lab record submission: 5 marks

### **II. Semester End Examination: 40 Marks**

- a. Write an essay on a given topic or participate in an activity: 15 Marks  
b. Interview or Group Discussion: 15 Marks  
c. *Viva Voce* 10 marks

### **References:**

- Adair, John. *Effective Communication*. London: Pan Macmillan Ltd., 2003.  
Ajmani, J. C. *Good English: Getting it Right*. New Delhi: Rupa Publications, 2012.  
Amos, Julie-Ann. *Handling Tough Job Interviews*. Mumbai: Jaico Publishing, 2004.  
Collins, Patrick. *Speak with Power and Confidence*. New York: Sterling, 2009.  
Fensterheim, Herbert and Jean Baer. *Don't Say Yes When You Want To Say No*. New York: D  
Raman, Meenakshi & Sangeeta Sharma. *Technical Communication: Principles and Practice*. Second Edition. New Delhi: Oxford University Press, 2011

### **E-Learning Resources:**

- <http://www.dailywritingtips.com/>  
<http://www.englishdaily626.com/c-errors.php>  
<http://www.owl.net.rice.edu/~cainproj/>  
<http://www.thehumorsource.com/>  
<http://www.indiabix.com/group-discussion/topics-with-answers/>  
<http://networketiquette.net/>  
<https://public.wsu.edu/~brians/errors>

Unit No	Unit name	Periods	Questions for SEE			Marks weightage	%Weightage
			R	U	A		
1.	Introduction to Employability Skills	6			2	2	
2	JAM/ Group Discussions	9			2	2	
3	Interview Skills	9			2	2	
4.	Presentation Skills	9			2	2	
5.	Writing skills at work place	6			1	1	
6.	Workplace awareness	6			1	1	
	<b>Total</b>	<b>45</b>			<b>10</b>		<b>100</b>

**BOARD DIPLOMA EXAMINATION (C-21)**  
**MID SEMESTER EXAMINATION – I**  
**HU-410- EMPLOYABILITY SKILLS LAB**

**Time: 1 Hour**

**Total Marks: 20**

**Part – A**

**10 marks**

*Instruction: Answer any one of the following questions.*

1. Write a paragraph on the importance of employability skills.
2. List out the important employability skills.
3. Mention the different strategies to enhance the employability skills.

**Part – B**

**10 marks**

*Instruction: Answer any one of the following questions.*

4. What are the rules to be implemented in a JAM session?
5. What are the do's and don'ts of a group discussion.
6. List out the steps involved in a group discussion and mention some phrases and expressions commonly used.

**BOARD DIPLOMA EXAMINATION (C-21)**  
**MID SEMESTER EXAMINATION - II**  
**HU-410- EMPLOYABILITY SKILLS LAB**

**Time : 1 Hour**

**Total Marks: 20**

**Part – A**

**10 marks**

*Instruction: Answer any one of the following questions.*

1. Write a list of frequently asked questions in an interview. Write the answers for the questions.
2. Mention the instructions to attend a telephonic interview.
3. What are the do's and don'ts for a formal interview?

**Part – B**

**10 marks**

*Instruction: Answer any one of the following questions.*

4. Write the various steps involved in making presentations effectively.
5. What are the do's don'ts of body language during a presentation?
6. List out a few audio-visual aids and explain their role in making an effective presentation.

**BOARD DIPLOMA EXAMINATION (C-21)**  
**SEMESTER END EXAMINATION**  
**HU-410- EMPLOYABILITY SKILLS LAB**

**Time: 3 Hours**

**Total Marks:**

**40**

**Part – A**

**10 marks**

*Instruction: Pick any one question from the given lot.*

1. How are employability skills helpful to secure a good job?
2. Describe the steps involved in JAM and group discussion.
3. Write the guidelines involved in making a good presentation.
4. List few professional ethics useful at workplace.
5. Mention few skills involved in writing at workplace.

**Part – B**

**15 marks**

6. Interview / Group Discussion

**Part – C**

**15 marks**

7. *Viva Voce*

### ME-411-Skill Upgradation

Course Title	Skill Upgradation	Course Code	ME-411
Semester	IV	Course Group	Practical
Teaching Scheme in Periods (L:T:P:)	0:0:8	Credits	2.5
Methodology	Practical's	Total Contact Periods	120

#### ME-402

1. Study movement of cam and draw cam profile.
2. Design a open belt drive for a simple application.
3. List out and identify common bearings and the material used

#### ME-403

1. Visit a nearby industry
  - a. Know the complete process and identify energy produced and utilised areas
  - b. conduct energy auditing and draw heat balance sheet by using excel sheet
  - c. From the above heat balance sheet, identify the areas of energy wastage and find remedies.
  - d. Prepare a report and present a seminar
2. Solve Velocity triangles problems by graphical method using CAD software and analyse.
3. Prepare a model of Turbines, Pumps

#### ME-404

1. Search for literature from journal to know latest trends in Marching metods and present a seminar with PPT's
2. Make a gear using wood or plastic.

#### ME-406

1. Visit a nearby fabrication industry / repair shop or any
  - a. Identify one product prepared by machining and involving 4/5 individual parts and
  - b. Measure the dimensions and the geometrical shapes of the parts
  - c. Prepare a production drawing of product model involving Limit, Fits and Tolerances
  - d. Prepare the process sheet for all the possible parts