

C21_ Curriculum

DIPLOMA IN MECHANICAL ENGINEERING



OFFERED BY

STATE BOARD OF TECHNICAL EDUCATION & TRAINING,

TELANGANA: HYDERABAD

V SEMESTER

Sl No	Course Code	Course Name	Teaching Scheme				Credits	Examination Scheme						
			Instruction periods per week			Total Periods per semester		Continuous internal evaluation			Semester end examination			
			L	T	P			Mid Sem 1	Mid Sem 2	Internal evaluation	Max Marks	Min Marks	Total Marks	Min marks for Passing including internal
1	ME-501	Industrial Management and Entrepreneurship	4	1	0	75	3	20	20	20	40	14	100	35
2	ME-502	Refrigeration and Air-Conditioning	4	1	0	75	3	20	20	20	40	14	100	35
3	ME-503	CAD/CAM	4	1	0	75	3	20	20	20	40	14	100	35
4	ME-574	Industrial Engineering & Estimation and Costing	4	1	0	75	3	20	20	20	40	14	100	35
5	ME-584	Mechatronics												
6	ME-575	Fluid Power Systems	4	1	0	75	3	20	20	20	40	14	100	35
7	ME-585	Automobile Engineering												
8	ME-506	CAM LAB	1	0	2	45	1.5	20	20	20	40	20	100	50
9	ME-507	Advanced Manufacturing & Fabrication Engineering Lab	1	0	2	45	1.5	20	20	20	40	20	100	50
10	ME-508	Refrigeration and Air Conditioning Lab	1	0	2	45	1.5	20	20	20	40	20	100	50
11	ME-509	Metrology & Pneumatics Lab	1	0	2	45	1.5	20	20	20	40	20	100	50
12	ME-510	Project Work	0	0	3	45	1.5	20	20	20	40	20	100	50
13	ME-511	Skill Upgradation	0	0	8	120	2.5	0	0	Rubrics	--	-		

Activities: student performance is to be assessed through Rubrics

ME-501 - INDUSTRIAL MANAGEMENT AND ENTREPRENEURSHIP

Course title	Industrial Management and Entrepreneurship	Course code	ME-501
Semester	V	Course group	Core
Teaching scheme in periods (L:T:P)	4:1:0	Credits	3
Methodology	Lecture+ Tutorial	Total Contact Periods	75
CIE	60 Marks	SEE	40 Marks

Prerequisites: Knowledge of Basic Sciences.

COURSE OUTCOMES

On successful completion of the course, the students will be able to

Course Outcomes	
CO1	Understand the principles and functions of management and Outline Organization structure & organizational behavior
CO2	Understand the Functions of Production Management
CO3	Analyse the functions of Materials Management.
CO4	Compare Marketing, sales & Feasibility study.
CO5	Know the use of ISO 9000 & T.Q.M
CO6	Understand Industrial legislation & safety and role of entrepreneur and entrepreneurial development

Blue Print of Marks for SEE:

Units		No of periods	Questions to be set for SEE			Remarks		
			R	U	A			
Part-A	1.Principles and functions of management and organisation structure and behaviour	13	Q4	Q1	Q9(a)	Q13(a)		
	2.Production management	12						
Part-B	3.Materials management	13		Q2	Q10(a)	Q14(a)		
	4.Marketing, sales & feasibility study	12						
Part-C	5.Introduction to ISO 9000 & T.Q.M	13		Q3	Q5 Q6	Q9(b) Q11(a) Q11(b)	Q13(b) Q15(a) Q15(b)	
	6.Industrial legislation & safety and Entrepreneurial development	12						Q7 Q8
TOTAL		75	08	08	08			

COURSE CONTENT

1. Principles and functions of management and organisation structure and behaviour

Definitions of Industry, Commerce and Business, Evolution of management theories, Principles of Scientific Management, functions of management, Difference between administration and management, Role of industry, Types of ownership – Sole proprietorship, Partnership, Private limited, public limited company, Industrial Cooperatives, Philosophy, types of Organizations, Line and Staff and functional organizations, Advantages, limitations, departments in a large-scale industry, Effective organization, Motivation, different theories of motivation, leadership styles.

2. Production management

Production, planning and control, relation with other departments, need for planning and its advantages, Routing, scheduling, dispatching, PERT and CPM, simple problems.

3. **Materials management**

Materials in industry, inventory control model, ABC Analysis, Safety stock, re-order level, Economic ordering quantity, Stores layout, stores equipment, Stores records, purchasing procedures, purchase records, Bin card, Cardex.

4. **Marketing, sales & feasibility study**

Sellers and Buyers markets, Marketing, Sales, Market conditions, monopoly, oligopoly, perfect competition, Cost -Elements of Cost, Contribution, Break even analysis, Market Survey, Product and production Analysis, Materials input, Manpower, Location, Economic and Technical Evaluation, preparation of Feasibility study reports.

5. **Introduction to ISO 9000 & T.Q.M**

Concept of quality, Definition of the terms quality policy, quality management, quality systems, quality control and quality assurance, Elements of quality systems: Management responsibility, Quality system, contract review, design control, document control, purchasing, purchaser– supplied product, product identification and traceability, process control, Inspection and testing. Definition and Principles of quality assurance, Know the necessity of International standards –ISO- Evolution, Meaning, importance, Various standards under ISO, ISO 9000 series of standards- Features, series, Constituents, Advantages, Draw backs and beneficiaries (Whom does ISO 9000 help). 5-S principles-concept of zero defects. TQM-Meaning, Characteristics.

6. **Industrial legislation & safety and Entrepreneurial development**

Employer – Employee relations, Trade, Union Settlement of disputes, collective bargaining, Welfare activities, Total Welfare concept, rights and responsibilities of Employers and employees, Salient features of Indian Factories Act, Importance of Safety at work places, Hazards, causes of accidents, Entrepreneur and entrepreneurship -Concept, definition, role, expectation, Entrepreneurship Vs Management, promotion of S.S.I. Self – employment schemes, Product selection, site selection, Institutional support needed, financial assistance programs. Start up Scheme- Importance, Features and Eligibility for startup registration, Benefits

REFERENCE BOOKS

1. Industrial engineering and management by O.P Khanna.
2. Production management by Buffa
3. Industrial Engineering & Management Science by TR Banga
4. Engineering Economics and management science by Banga & Sharma
5. Personnel management by Flippo
6. Entrepreneurship by NITTTR Chennai.

ELECTRONIC RESOURCES

1. <https://nptel.ac.in/courses/>
2. <https://www.slideshare.net/>
3. <https://en.wikipedia.org/wiki/>
4. <http://ndl.ethernet.edu.et/bitstream/>

SUGGESTED STUDENT ACTIVITIES

1. Identify any 5 industries with different types of ownerships.
2. Prepare an organizational structure of institution
3. Make a survey on marketing a product.
4. Prepare a list of ISO 9000 series as well as latest quality standards
5. Prepare sign boards representing safety measures.
6. Role play as an entrepreneur

SUGGESTED LEARNING OUTCOMES

Upon completion of the course the student shall be able to

1. Understand the principles and functions of management and Outline Organization structure & organizational behavior

- 1.1 Define industry, commerce (Trade) and business.
- 1.2 Know the need for management.
- 1.3 Understand the evolution of management
- 1.4 Explain the principles of scientific management.
- 1.5 Understand functions of Management.
- 1.6 Differentiate between management and administration.
- 1.7 Understand types of ownerships
- 1.8 Differentiate types of ownerships.
- 1.9 Understand salient features of joint stock companies.
- 1.10 Understand the philosophy and need of organization structure of an industry.
- 1.11 Understand the line, staff and Functional organizations.
- 1.12 List the advantages and limitations of line, staff and functional organizations.
- 1.13 List different departments in a large scale industry.
- 1.14 Explain the factors of effective organization.
- 1.15 Understand organizational behaviour.
- 1.16 Explain job analysis.
- 1.17 State motivation theories.
- 1.18 State Maslow 's Hierarchy of needs.
- 1.19 List out different leadership models.
- 1.20 Explain the trait theory and behavior theory of leadership

2. Understand the Functions of Production Management

- 2.1 Differentiate production, planning and control.
- 2.2 Relate the production department with other departments.

- 2.3 State the need for planning and its advantages.
- 2.4 Explain the stages of Production, planning and control.
- 2.5 Explain routing methods.
- 2.6 Explain scheduling methods.
- 2.7 Explain dispatching.
- 2.8 Draw PERT/CPM networks.
- 2.9 Identify the critical path
- 2.10 Problems on PERT & CPM.

3 Analyze the functions of Materials Management

- 3.1 State the importance of material management.
- 3.2 Objectives and functions of material management.
- 3.3 Derive expression of EOQ for inventory control.
- 3.4 Explain ABC analysis.
- 3.5 Define safety stock, Buffer stock
- 3.6 Define reorder level.
- 3.7 Functions of stores department, duties of store keeper
- 3.8 Explain stores layout,
- 3.9 Explain the stores records.
- 3.10 Describe Cardex method.
- 3.11 Objectives and functions of purchasing department
- 3.12 Explain purchasing procedures.
- 3.13 List out purchase records.
- 3.14 Describe the stores equipments

4 Compare Marketing, sales & Feasibility study.

- 4.1 Explain marketing functions.
- 4.2 Explain Sales function.
- 4.3 List out marketing conditions.
- 4.4 Differentiate Sellers and Buyers 'market.
- 4.5 Differentiate monopoly, oligopoly, and perfect competition.
- 4.6 Steps in conducting market and demand surveys.
- 4.7 Advantages and disadvantages of market and demand surveys
- 4.8 Differentiate product and production analysis.
- 4.9 Identify the input materials, i.e. Bill of materials
- 4.10 Explain the concept of cost..
- 4.11 Explain break-even analysis..
- 4.12 Evaluate Economic and Technical factors.
- 4.13 Preparation of feasibility study.
- 4.14 List out different products currently in demand with market or industry.

5 Know the use of ISO 9000 & T.Q.M

- 5.1 Understand the concept of quality.
- 5.2 Know the quality systems and elements of quality systems.
- 5.3 Know the principles of quality Assurance.
- 5.4 Know the evolution of ISO standards.
- 5.5 Discuss ISO standards and ISO 9000 series of quality systems.
- 5.6 State the constituents of ISO 9000 series of standards for quality systems.
- 5.7 Benefits and Drawbacks of ISO 9000 series of standards.
- 5.8 List out the beneficiaries of ISO 9000.
- 5.9 Understand 5-S principles and ZERO DEFECT
- 5.10 Know TQM concept and elements.

6 Understand Industrial legislation & safety and role of entrepreneur and entrepreneurial development

- 6.1 Describe employer and employee relations.
- 6.2 Objectives, functions, advantages and disadvantages of Trade Unions.
- 6.3 Explain Causes and settlements of industrial disputes..
- 6.4 List out Welfare activities..
- 6.5 List out the rights and responsibilities of employees and employers.
- 6.6 List out the salient features of Indian Factories Act.
- 6.7 Explain the importance of safety at Work place.
- 6.8 List out the important provisions related to safety.
- 6.9 Explain hazard and accident.
- 6.10 Explain the causes of accidents..
- 6.11 Define the word entrepreneur..
- 6.12 Difference between entrepreneurship and management.
- 6.13 Explain, expectations, role and qualities of an entrepreneur..
- 6.14 Determine the role of entrepreneurs in promoting Small Scale Industries.
- 6.15 Describe the details of self-employment schemes.
- 6.16 Explain the method of product selection.
- 6.17 Explain the method of site selection.
- 6.18 List the financial assistance programs.
- 6.19 List out the organizations that help an entrepreneur
- 6.20 Importance of Start-ups
- 6.21 Different Start-up schemes
- 6.22 Features and Eligibility for startup registration
- 6.23 Benefits of Start-ups

COURSE OUTCOMES		CL	Linked POs	Teaching Periods
CO1	Understand the principles and functions of management and Outline Organization structure & organizational behavior	R, U, A	5,6,7	13
CO2	Understand the Functions of Production Management	R, U, A	2,5,6	12
CO3	Analyse the functions of Materials Management.	U, A	1,6,7	13
CO4	Compare Marketing, sales & Feasibility study.	U, A	1,6,7,	12
CO5	Know the use of ISO 9000 & T.Q.M	U, A	1,6,7	13
CO6	Understand Industrial legislation & safety and role of entrepreneur and entrepreneurial development	R, U, A	1,6,7	12
			Total Periods	75

Legends: R = Remember; U= Understand; A= Apply and above levels (Bloom's revised taxonomy)

CO-PO Attainment Matrix:

COURSE OUTCOMES	PROGRAM OUTCOMES						
	PO1	PO2	PO3	PO4	PO5	PO6	PO7
CO1					2	3	1
CO2		2			1	3	
CO3	1					2	3
CO4	1					3	2
CO5	2					3	1
CO6	1					2	3

Level 3- Highly Addressed, Level 2-Moderately Addressed, Level 1-Lowly Addressed.

MID SEM-I EXAM

S.No	Unit Name	R	U	A	Remarks
1	Principles and functions of management and organisation structure and behaviour	1, 2	5(a) 5(b)	7(a) 7(b)	
2	Production management	3, 4	6(a) 6(b)	8(a) 8(b)	
Total Questions		4	4	4	

MID SEM-I EXAM

S.No	Unit Name	R	U	A	Remarks
1	Materials management	1, 2	5(a) 5(b)	7(a) 7(b)	
2	Marketing, sales & feasibility study	3, 4	6(a) 6(b)	8(a) 8(b)	
Total Questions		4	4	4	

Legend	Remembering (R)	1 Mark
	Understanding (U)	3 Marks
	Application (A)	5 Marks

MID SEM-I Model Paper
ME-501-INDUSTRIAL MANAGEMENT AND ENTREPRENEURSHIP

Time: 1 hr

Max. Marks:20

PART-A

4x1=4Marks

- NOTE: 1) Answer all questions and each carries **one** mark.
2) Answers should be brief and straight to the point and shall not be exceed three simple sentences.
1. Define Industry.
 2. Write any two qualities of a leader.
 3. What do you mean by Planning?
 4. What does CPM Stands for.?

PART-B

2X3M=6

Marks

- NOTE: 1) Answer all questions and each carries **three** mark.
2) Answers should be comprehensive and the criterion for valuation is the content but not length of the answer.
- 5.(a) what is administration
- OR
- 5.(b) List out theories of motivation.
- 6.(a) what is the need for planning.
- OR
- 6.(b) what is routing?

PART-C

2X5M=10

Marks

- NOTE: 1) Answer all questions and each carries **five** mark.
2) Answers should be comprehensive and the criterion for valuation is the content but not length of the answer.
- 7.(a) Explain the principles of scientific management
- OR
- 7.(b) a) Compare between PERT AND CPM.
b) Explain about Scheduling and Dispatching.
- 8.(a) Draw the project network of the given project and identify all paths through it.
Find the critical path, TL and T_E on the network.

Activity	Optimistic Time(a)	Most likely Time (m)	Pessimistic Time (b)
1-2	1	1	7
1-3	1	4	7
1-4	2	2	8
2-5	1	1	1
3-5	2	5	14
4-5	2	6	10
5-6	3	6	15

OR

- 8.(b) State the ERG theory of motivation.

MID SEM-II
Model Paper:: ME-501
INDUSTRIAL MANAGEMENT AND ENTREPRENEURSHIP

Time: 1 hr

Max. Marks:20

PART-A

4x1=4Marks

NOTE: 1) Answer all questions and each carries **one** mark.
2) Answers should be brief and straight to the point and shall not be exceed three simple sentences.

1. Write the formula to calculate EOQ?
2. What is Buffer Stock?
3. What Is feasibility study?
4. What is Breakeven Point?

PART-B

2X3M=6 Marks

NOTE: 1) Answer all questions and each carries **three** mark.
2) Answers should be comprehensive and the criterion for valuation is the content but not length of the answer.

5.(a) List the advantages of ABC analysis.

OR

5.(b) State the functions of Material Management.

6.(a) List out the element of cost ?

OR

6.(b) what is buyer's market and seller's market.

PART-C

2X5M=10

Marks

NOTE: 1) Answer all questions and each carries **five** mark.
2) Answers should be comprehensive and the criterion for valuation is the content but not length of the answer.

7.(a) Explain the functions of Purchase management.

OR

7.(b) Explain various records used in stores.

8.(a) What is Break Even analysis? Illustrate graphically the concept of Break even point.

OR

8.(b) Differentiate product and product analysis.

BOARD DIPLOMA EXAMINATION, (C-21)
SEE-MODEL PAPER ME-501
DME– V SEMESTER EXAMINATION
INDUSTRIAL MANAGEMENT AND ENTREPRENEURSHIP

Time: 2 Hours

Max. Marks: 40

PART-A

8 X 1 =

8

Instructions: 1. Answer **ALL** questions.
2. Each question carries **ONE** mark.

1. Define Trade.
2. What is a bin card
3. List two benefits of ISO 9000 certification.
4. Define a Network.
5. Define quality control.
6. What is ISO.
7. What is the purpose of Trade unions.
8. Define an entrepreneur.

PART-B

4 X 3 =

12

Instructions: 1. Answer **ALL** questions.
2. Each question carries **THREE** marks.

9. (a) State any three differences between share and debenture.
OR
9. (b) What are the 5-S principles.
10. (a) List any three advantages of ABC analysis.
OR
10. (b) Mention three qualities required for a good entrepreneur .
11. (a) List the beneficiaries of ISO 9000
OR
11. (b) State the features of ISO 9000.
12. (a) What are the expectations of an entrepreneur
OR
12. (b) Explain the significance of collective bargaining.

PART-C

4 X 5 = 20

- Instructions:** 1. Answer **ALL** questions.
2. Each question carries **FIVE** marks.

13. (a) Explain the principles of Scientific management stated by F.W. Taylor

OR

13(b) What is quality system? Explain various elements of quality systems.

14 (a) Explain ABC analysis in inventory control with graph.

OR

14(b) Explain the factors influencing the site selection for a plant location.

15 (a) What is TQM? Write the principles or elements of TQM.

OR

15(b) Explain the importance of certification of confirmation to ISO 9000 and the procedure of obtaining it ?

16(a) List out the three rights and responsibilities of Employees.

OR

16(b) State Indian electricity rules with regard to safety.

ME-502-REFRIGERATION AND AIR CONDITIONING

Course Title:	Refrigeration and Air Conditioning	Course Code:	ME-502
Semester:	V	Course group :	Core
Teaching Scheme(L:T:P):	4:1:0	Credits:	3
Methodolgy :	Lecture + Assignment	Total contact periods:	75
CIE:	60 Marks	SEE:	40 Marks

Prerequisites: Basic knowledge of Thermodynamics

COURSE OUTCOMES

	On Successful completion of the course, the student will be able to
CO 1	Analyze the methods of refrigeration and interpret air refrigeration cycles.
CO 2	Evaluate Vapour compression, vapour absorption refrigeration systems.
CO 3	Explain Refrigerants and various equipment used in refrigeration.
CO 4	Analyze Air conditioning and understand psychrometry.
CO 5	Assess working of various air conditioning equipment.
CO 6	Explain different applications of refrigeration and air conditioning systems.

COURSE CONTENT AND BLUE PRINT OF MARKS FOR SEE

Unit No	Unit Name	Periods	Questions to be set for SEE (Q No)			Remarks		
			R	U	A			
1	Air refrigeration systems	12	4	1	9(a)	13(a)		
2	Vapour refrigeration systems	13						
3	Refrigerants and refrigeration equipment	13		2	10 (a)	14 (a)		
4	Air conditioning & Psychrometry	12						
5	Distribution of air - Air conditioning equipment	12		3	5, 6	9(b), 11(a), 11(b)	13(b), 15(a), 15(b)	
6	Applications of refrigeration and air conditioning	13						7, 8

Legend: R; Remembering, U: Understanding A: Applying

COURSE CONTENT

Refrigeration and Air conditioning

Unit – 1

Duration: 12 Periods (L: 10 – T:2)

Air refrigeration systems

Definition of refrigeration , Air conditioning - methods of refrigeration – Basic terms involved in refrigeration – Thermodynamic analysis of Reversed Carnot refrigeration cycle and Bell Coleman refrigeration cycle - Open air refrigeration system and closed air refrigeration system.

Unit – 2

Duration: 13 Periods (L: 10 – T: 3)

Vapour refrigeration Systems

Vapour compression refrigeration system (VCRS):-Principle –Thermodynamic analysis of VCRS -Factors effecting performance of VCRS - Wet and dry compression –Receiver, Accumulator, strainer , drier and flash chamber.

Vapour absorption refrigeration system(VARS):-Principle – Refrigerant absorbent pairs-**Two fluid VARS:-** Working of Ammonia water vapour absorption refrigeration system – Working of Lithium Bromide- Water vapor absorption refrigeration system-**Three fluid VARS :**Electrolux refrigeration system - Expression for COP of VARS.

Unit – 3

Duration: 13 Periods (L:10 – T:3)

Refrigerants and refrigeration equipment

Refrigerants:- Definition - Primary and secondary refrigerants -- properties of good refrigerants – Commonly used refrigerants – Ozone depletion, phase out of Chlorofluoro carbon refrigerants – Montreal and Kyoto protocols

Refrigeration equipment :- Compressors: Classification – Hermetic compressor –

Condensers: types - Natural draught, forced draught, evaporative and shell & tube condensers –**Expansion devices:** Capillary tube and thermostatic expansion valve.-

Evaporators: Dry expansion evaporator, Flooded evaporator – Bare tube, finned tube and Plate surface evaporator.

Unit – 4

Duration: 12 Periods (L: 10 – T:2)

Air conditioning & Psychrometry

Fundamentals of A/C:- Definition of air conditioning - Classification of air conditioning systems - Human comfort conditions – Effective temperature – Factors governing effective temperature – comfort chart.

Psychrometry:-Definition– Psychrometric terms – Carrier Equation - Psychrometric chart – Psychrometric processes

Unit – 5

Duration: 12 Periods (L: 10 – T:2)

Air Distribution

Modes of heat transfer :- Heating loads – cooling loads. **Air distribution :-**General Air distribution (Air flow diagram for an ac system) – **Air distribution system in a Room :-** Ejection system, Downward system and Upward system. -**Ducts:** -Definition, Types, material used, Duct system. Fans and blowers – Supply air outlets – Filters – Heating and cooling coils - AHU (Air handling units). - Chiller

Unit – 6

Duration: 13 Periods (L:10 – T:3)

Applications of refrigeration and air conditioning

Applications of refrigeration :- Domestic refrigerator – Ice plant – Water cooler – Production of Dry Ice. **Applications of air conditioning**:-Window air conditioner, Desert/air cooler(**Evaporative cooling**), Summer air conditioning system – Winter air conditioning system – year round air conditioning system – Central air conditioning system

REFERENCE BOOKS

1. Refrigeration and Air Conditioning – by C. P Arora
2. Refrigeration and Air Conditioning – by Domakundwar
3. Basic Refrigeration and Air conditioning - by P N Ananthanarayana
4. Refrigeration and Air Conditioning – by Dosatt
5. Refrigeration and Air Conditioning – by Stoecker

SUGGESTED LEARNING OUTCOMES

1.0 Air refrigeration systems

- 1.1 Define refrigeration and know natural method and mechanical methods of refrigeration.
- 1.2 Explain different methods of refrigeration such as ice, dry, ice, Air expansion refrigeration.
- 1.3 Define Refrigeration effect, Work of compression, COP, unit of refrigeration (Ton of refrigeration- TR), Evaluate power required per ton of refrigeration and simple problems.
- 1.4 Analyze reverse Carnot refrigeration cycle -Know its limitations.
- 1.5 Know expression for COP of reverse Carnot refrigeration cycle (derivation omitted) and solve problems on it.
- 1.6 Analyze Bell-Coleman air cycle.
- 1.7 Know expression for COP of Bell-Coleman air refrigeration cycle (derivation omitted) and Solve problems on it.
- 1.8 Differentiate open air system and closed air system.

2.0 Vapour refrigeration Systems

- 2.1 Explain principle and working of simple (basic) vapour compression refrigeration system with the help of T-S and P-h diagrams.
- 2.2 Write the expression for its COP
- 2.3 Distinguish between wet and dry compression.

- 2.4 State the use of receiver, accumulator, strainer, drier and flash chamber.
- 2.5 Solve simple problems on basic vapour compression refrigeration system
- 2.6 Summarize the effects of evaporator pressure, condenser pressure, under cooling and super heating on COP.
- 2.7 Explain principle of simple vapor absorption systems.
- 2.8 State the desirable properties of refrigerants -absorbers and list commonly used refrigerant – absorber pairs.
- 2.9 Know two fluid systems of Vapour absorption refrigeration system (VARs) – Explain the construction and working of Ammonia-Water VARs
- 2.10 Explain the construction and working of Water-Lithium Bromide VARs.
- 2.11 Know three fluid systems of VCRS – Explain the construction and working of Electrolux VARs.
- 2.12 Write expression of COP of VARs (without derivation) and solve simple problems

3.0 Refrigerants and refrigeration equipment

- 3.1 Distinguish between primary and secondary refrigerants.
- 3.2 List the desirable properties of refrigerants and Classify refrigerants.
- 3.3 Know the difference between chloro fluoro carbon refrigerants, hydro chloro fluoro refrigerants and hydro carbon refrigerants.
- 3.4 Write chemical formula designation name and application of the following refrigerants – R 12, R 22, R 134 a, R 290a, R 600a, R 401a, Cyclopentane, Care 30 , R 717, R 718, R 729, R 744
- 3.5 Know the reasons of Ozone depletion – Need to phase out of Chlorofluoro carbons and hydro Choro fluoro carbons –
- 3.6 Understand Montreal protocol and Kyoto protocol. (Statements of protocol)
- 3.7 Know the function of compressor, Classification of compressors
- 3.8 Explain construction and working of hermetic reciprocating compressor.
- 3.9 State the function of condenser and explain the working of natural draught air cooled condensers type (tube and fin condenser) –and forced draught air cooled condensers
- 3.10 Explain the working of shell & tube water cooled condensers with help of a legible sketch.
- 3.11 Explain the function of expansion devices. Know working of capillary tube.
- 3.12 Explain thermostatic expansion valve with the help of a legible sketch.
- 3.13 State the function of evaporator – Explain construction and working of plate surface evaporator.

3.14 Explain construction and working principle of flooded type evaporator with a sketch

4.0 Air conditioning & Psychrometry

4.1 Define air conditioning and classify air conditioning systems

4.2 Know the following terms: human comfort, effective temperature and comfort chart.

4.3 Define the terms: Psychrometry, dry air and moist air, DBT, WBT, DPT and adiabatic saturation temperature, humidity, absolute humidity, relative humidity, specific humidity.

4.4 Know carrier's equation and solve problems involving psychrometry.

4.5 Know different psychrometers- Laboratory, continuous recording, sling, aspirating psychrometers.

4.6 Explain the features of psychrometric chart, plot all psychrometric processes on the chart.

4.7 Simple problems on psychrometric processes using psychrometric chart only.

4.8 Know the concept of mixing of air streams and solve problems.

5.0 Air Distribution

5.1 Know the different modes of heat transfer – conduction, convection and radiation

5.2 Draw the general air flow diagram for AC system and explain the air flow, explain different air distribution systems in a room like ejection system, downward system and upward system.

5.3 Explain the need of duct- Know duct materials, shapes and classify ducts

5.4 Explain the duct system based on arrangement of supply ducts like: loop perimeter system, radial perimeter system and extended plenum system.

5.5 Explain duct system based upon number of ducts used like: single duct system, dual duct system and dual duct with induction system.

5.6 Differentiate fan and blower.

5.7 Know the factors governing selection of fans.

5.8 Classify fans according to direction of air flow.

5.9 Classify supply air outlets and know about grill outlets, slot diffusers, ceiling diffusers, perforated ceiling panels and their applications.

5.10 Know different types of filters (Dry, Viscous, Wet, Electronic and HEPA filters)-

5.11 Explain heating and cooling coils.

5.12 Know about air handling unit (AHU).

5.13 Know the function of chillers in air conditioning.

6.0 Applications of refrigeration and air conditioning

- 6.1 Explain construction and working of domestic refrigerator.
- 6.2 Explain the layout of ice plant and process of production of ice
- 6.3 Explain construction and working of storage type water cooler.
- 6.4 Explain the process of production of dry ice
- 6.5 Explain working of window air conditioner.
- 6.6 Know the difference between unitary air conditioner, split air conditioner
- 6.7 Explain the working of desert type air cooler.
- 6.8 Explain summer air conditioning system for hot & humid out door conditions and hot & dry conditions.
- 6.9 Explain winter air conditioning system for cold & dry out door conditions
- 6.10 Explain year round air conditioning system.
- 6.11 Explain central air conditioning system

SUGGESTED E-RESOURCES / STUDENT ACTIVITIES.

1. Visit nearest outlet and list out Domestic Refrigerators manufacturers and know the capacity of the refrigerator and the refrigerant used in it.
2. Know the colour coding of refrigerant cylinders.
3. Make a report of Montreal and Kyoto protocols.
4. Assemble and disassemble the air cooler and know all the parts.
5. Clean an air cooler, replace pads of air cooler.
6. Visit a RAC workshop and watch the method of vacuumisation and charging of refrigerant.
7. Visit a duct manufacturing unit and study how fabrication is done and submit a report.
8. Visit a site where ducting is being carried out.
9. Collect data sheet to find heating and cooling loads for an air conditioning system and study its contents.
10. Visit a site where split air conditioner is being installed.
11. Visit a central air conditioning plant.
12. Working of domestic refrigerator
: <https://www.youtube.com/watch?v=h5wQoA15OnQ&vl=en>
13. Working of window air conditioner:
<https://www.youtube.com/watch?v=0PkOEHMNOLk>
14. Working of Air handling unit (AHU)
<https://www.youtube.com/watch?v=uWwVsFqNFp4>
15. Working of chiller

<https://www.youtube.com/watch?v=0rzQhSXVq60>

16. Working of ductable air conditioning system

https://www.youtube.com/watch?v=ye_r_JY5Vyg

17. Working of tube axial fan

<https://www.youtube.com/watch?v=OvVcZrIWcF8>

18. Working of vapour compression system

https://www.youtube.com/watch?v=-Wj_MO4BqtA

19. Working of Ammonia Water VARS

<https://www.youtube.com/watch?v=xDDmlT-HK1Y>

20. Working of Water lithium bromide VARS

https://www.youtube.com/watch?v=L_wISd7bAWE

21. Working of Electrolux VARS

<https://www.youtube.com/watch?v=uHtOtgxAdRs>

22. Working of Receiver, Drier and Accumulator

<https://www.youtube.com/watch?v=7raEl5-5PEs>

CO-PO Matrix

CO	PO1	PO2	PO3	PO4	PO5	PO6	PO7	Mapping POs
CO1	2	3	2	-	-	1	2	1, 2,3,6,7
CO2	2	3	2	-	-	1	2	1, 2,3,6,7
CO3	1	3	2	-	3	2	2	1, 2,3,5, 6,7
CO4	2	3	2	-	-	1	2	1, 2,3,6,7
CO5	2	3	2	-	-	1	2	1, 2,3,6,7
CO6	2	3	2	-	-	1	2	1, 2,3,6,7

Course-PO Attainment Matrix

Course Name	Program Outcomes (PO)						
	1	2	3	4	5	6	7
R & A/c	2	3	2	-	1	1	2
Level 3- Highly Addressed, Level 2-Moderately Addressed, Level 1-Low Addressed							

QUESTION PAPER BLUE PRINT FOR CIE (MID SEM I)

Unit No	Unit Name	Questions to be set for CIE (Q No)			Remarks
		R	U	A	
1	Air refrigeration systems	1	5(a)	7(a)	
		2	5(b)	7(b)	
2	Vapour refrigeration systems	3	6(a)	8(a)	
		4	6(b)	8(b)	

QUESTION PAPER BLUE PRINT FOR CIE (MID SEM II)

Unit No	Unit Name	Questions to be set for CIE (Q No)			Remarks
		R	U	A	
3	Refrigerants and refrigeration equipment	1	5(a)	7(a)	
		2	5(b)	7(b)	
4	Air-conditioning and Psychrometry	3	6(a)	8(a)	
		4	6(b)	8(b)	

BOARD DIPLOMA EXAMINATIONS (C21)
MID SEM I EXAMINATION
DME V SEMESTER
REFRIGERATION AND AIR CONDITIONING

Time : 1 Hour

Total Marks : 20 M

PART – A

Marks: 4 X 1M = 4 M

- NOTE: 1) Answer all questions and each question carries one mark.
 2) Answers should be brief and straight to the point and shall not exceed three simple sentences
1. Define the term Refrigeration effect. Write its units.
 2. Find COP of a refrigerating machine working on reverse carnot refrigerating cycle operating between -10°C and 40°C .
 3. Why wet compression is preferred in VCRS.
 4. Why Ammonia-water is most prominently used as refrigerant-absorbent in VARS.

PART – B

Marks : 2 X 3M= 6 M

NOTE: 1) Answer **all** questions and each question carries **three** marks
 2) The answers should be comprehensive and the criteria for valuation is the content but not the length of the answer.

5. (a) Explain about dry ice refrigeration
 OR
5. (b) Differentiate open and closed cycle refrigeration system.
6. (a) Draw the layout of water-lithium bromide VARS..
 OR
- 6 (b) Draw layout of Electrolux refrigeration system.

PART – C

Marks : 2 X 5 M = 10 M

- NOTE :
1. Answer **all** questions and each question carries **five** marks.
 2. The answers should be comprehensive and the criteria for valuation is the content but not the length of the answer
- 7(a) Explain bell coleman refrigeration cycle with a layout
 OR
 - 7(b) A refrigeration plant works between -15°C and 30°C . The refrigerant is dry and saturated at the end of compression. Calculate Refrigerating effect, Carnot COP and COP of VARS, if enthalpies before and after compression are 1280 kJ/kg and 1470 kJ/kg, fluid enthalpy at 30°C is 320 kJ/kg.
 - 8 (a) Explain with help of pressure enthalpy diagram the effect of increase in condenser pressure on performance of refrigeration system
 OR
 - 8 (b) Differentiate wet compression with dry compression refrigeration system.

BOARD DIPLOMA EXAMINATIONS (C21)
MID SEM II EXAMINATION
DME V SEMESTER
REFRIGERATION AND AIR CONDITIONING

Time : 1 Hour

Total Marks : 20 M

PART – A

Marks: 4 X 1M = 4 M

NOTE: 1) Answer **all** questions and each question carries **one** mark.

2) Answers should be brief and straight to the point and shall not exceed **three** simple sentences

1. What is a primary refrigerant. Give an example.
2. What is chemical formula of R22 .
3. How does air conditioning differ from refrigeration.
4. Define the term specific humidity.

PART – B

Marks : 2 X 3M= 6 M

*NOTE: 1) Answer **all** questions and each question carries **three** marks*

2) The answers should be comprehensive and the criteria for valuation is the content but not the length of the answer.

5. (a) Write short notes on Montreal protocol
OR
5. (b) Differentiate natural draught and forced draught refrigerant condensers.
6. (a) What are the factors governing effective temperature
OR
- 6 (b) Explain working of aspirating psychrometer.

PART – C

Marks : 2 X 5 M = 10 M

NOTE : Answer all questions and each question carries five marks.

7(a) Explain working of shell and tube condenser.

OR

7(b) Explain working of thermostatic expansion valve.

8 (a) Draw sensible heating, sensible cooling, humidification and dehumidification process on psychrometric chart.

OR

8 (b) Explain the concept of mixing of air streams in air conditioning.

BOARD DIPLOMA EXAMINATIONS (C21)
MODEL PAPER (SEE)
DME V SEMESTER
REFRIGERATION AND AIR CONDITIONING

TIME : 2 Hours

Max. Marks: 40

PART – A

Marks: 8 X 1 M = 8 M

NOTE : 1) Answer **all** questions and each question carries **one** marks.2) Answers should be brief and straight to the point and shall not exceeding **three** simple sentences

1. Define the term Ton of Refrigeration.
2. What is function of accumulator in VCRS.
3. Write any two duct materials.
4. Write carriers equation.
5. Write two materials used for ducts in air distribution.
6. What is relative humidity of Hyderabad.
7. What are main components in indoor unit of split air conditioner.
8. What does AHU stands for?

PART – B*Answer all questions. Each question carries three marks***4x 3 M = 12M**

9(a) Write expression for COP of refrigerator and heat pump of reverse Carnot refrigeration cycle

OR

9(b) Explain working of electronic filters.

10(a) what are secondary refrigerants give two examples.

OR

10 (b) Explain working of air cooler

11 (a) Differentiate slot diffuser and ceiling diffuser.

OR

11(b) Differentiate conduction and convection heat transfer

12(a) Draw the layout for production of dry ice.

OR

12(b) Draw the layout for storage type water cooler.

PART – C

Answer all questions. Each question carries five marks

4x 5 M = 20 M

13 (a) Explain bell coleman refrigeration cycle .

OR

13 (b) Explain radial perimeter duct system with a neat sketch.

14 (a) Explain working of hermetic reciprocating compressor.

OR

14 (b) Explain working of storage type water cooler.

15 (a) Explain ejector type air distribution system.

OR

15 (b) Explain loop perimeter duct system.

16 (a) Explain summer air conditioning system for hot and humid outdoor conditions

OR

16 (b) Explain working of a window air conditioner.

ME-503-CAD/CAM

Course Title:	CAD/CAM	Course Code:	ME-503
Semester:	V	Course group :	Core
Teaching Scheme(L:T:P):	4:1:0	Credits:	3
Methodolgy :	Lecture + Assignment	Total contact periods:	75
CIE:	60 Marks	SEE:	40 Marks

Prerequisites: Basic knowledge of Computers.

COURSE OUTCOMES

	At the end of the course the students will be able to :
1	Understand the basic concepts of Computer aided Design (CAD) and Computer Aided Manufacturing
2	Understand the Concepts of NC, CNC and DNC systems
3	Familiar with the CNC Machines and Components and Attachments
4	Familiar with the CNC Part Programming concepts
5	Understand the concepts of CIM, FMS and Additive Manufacturing
6	Familiar with the fundamentals of Robots, Automated Storage and Retrieval Systems and Automated Guided Vehicles.

COURSE CONTENT AND BLUE PRINT OF MARKS FOR SEE

Unit No	Unit Name	Periods	Questions to be set for SEE(Q No)			Remarks		
			R	U	A			
1	Introduction to Computer Aided Design and Manufacturing	10	4	1	9(a)	13(a)		
2	Introduction to NC, CNC and DNC Machines	15						
3	CNC Machines and their Components	12		2	10(a)	14 (a)		
4	CNC Part Programming	13						
5	CIM and Introduction to Additive Manufacturing	15		3	5 ,6	9(b), 11(a), 11(b)		13(b), 15(a), 15(b)
6	Fundamentals of Robotics and Automation	10						

Legend: R Remembering, U: Understanding A: Applying

COURSE CONTENTS

Unit – 1

INTRODUCTION TO COMPUTER AIDED DESIGN AND MANUFACTURING

Introduction to Computer Aided Design (CAD): Introduction to CAD- Benefits of CAD-Stages of CAD-List of CAD Input, Output and display devices - Types of CAD software-Features of different CAD software - computer communications-Types of computer communications networks, Advantages and Disadvantages.

Introduction to Computer Aided Manufacturing (CAM): Introduction to CAM- Functions of CAM-Benefits of CAM; Fundamentals of Computer Aided Process Planning CAPP and Types of CAPP: Generative and Retrieval, MRP I and MRP-II: Concept and advantages – Introduction to ERP and SAP and Advantages and Limitations.

Unit- 2

INTRODUCTION TO NC AND CNC MACHINES

Introduction to Numerical Control (NC) System - Classification of NC System, Features of NC system, Block diagram of NC System, Motion control in NC system, Feedback control of NC system, Applications of NC system, Advantages of NC system- Limitations of NC system in comparison to conventional systems.

Computer Numerical Control (CNC) Machining: Introduction to CNC, Manufacturing methodology of Modern CNC Machining, Classification of CNC Machining centers, Block diagram of CNC system, Functions of each components of CNC system, Features of CNC, Advantages and Disadvantages of CNC over NC, Applications of CNC.

Direct Numerical Control (DNC) systems: Basic concept of DNC, Block diagram of DNC system with basic components and working principle, Concept of DNC system with and without satellite, Functions of DNC, Advantages of DNC, Comparison between NC, CNC and DNC Machine tools.

Unit-3

CNC MACHINES AND THEIR COMPONENTS

Machining Centres (MC): Types, Construction features of machining centres, specification of MC, Components of CNC: Automatic tool changer, working of Tool gripper and tool magazine, types of tool magazines, Automatic pallet changer, Care and maintenance of CNC machines, Spindle drives, feed drives, Slide ways, types with illustrations- Bearings, linear motion bearings, recirculatory ball screws, Feedback devices, transducers, encoders, linear transducers.

Unit-4

CNC PART PROGRAMMING

Introduction, Steps involved in CNC part programming, Types of Part Programs: Manual and Computer Assisted- CNC Part Programming languages, CNC coordinate system: NC axis system for milling, drilling and turning, Co-ordinates referencing methods: Absolute positioning, Incremental positioning, Concept of Fixed point zero, Floating-point zero,

NC Part Programming: Structure of NC Part Programming, Standard NC Functions/Words used in NC Part Programming language, Preparatory functions (G-Codes): Interpolation -Linear Interpolation, Circular Interpolation, Cutter/Tool Compensation, Miscellaneous functions (M-Codes)- Part programming formats, Canned cycles: Simple Turning Cycle, Thread Cutting Cycles, Peck Drilling Cycles, Grooving Cycles, Subroutines, Macros – Programming: Practice problems on Plain turning, Step turning, Taper turning and thread cutting. APT programming: APT statements, Coding for simple examples.

Unit-5

CIM AND INTRODUCTION TO ADDITIVE MANUFACTURING

Computer integrated manufacturing system: Introduction, Definition of CIM, Various process involved in CIM – CIM Cycle with integration of all functions, Importance, Necessity and features of CIMS, Flexible Manufacturing System(FMS): Definition– Application characteristics of FMS, Need of FMS, Basic Components of FMS, Features of FMS, Advantages of FMS, Limitations of FMS. Computer Aided Inspection: Introduction to CNC CMM – features, working and advantages of CNC-CMM.

Additive Manufacturing (AM) - Introduction: Necessity of AM, Use of AM Parts, Types of materials for AM, Process or Steps in Additive manufacturing, Classification of AM processes, Concepts of AM Processes: Vat Photopolymerization / Stereolithography, Material Jetting, Binder jetting, Material extrusion, Powder bed fusion, Sheet lamination, Directed energy deposition, Benefits of AM, Disadvantages, Applications of AM, Distinction Between AM and CNC Machining.

Unit-6

FUNDAMENTS OF ROBOTICS AND AUTOMATION

Robotics: Definition of a robot, necessity, Degrees of freedom (DOF) of Robot, Classification of Robots: Definition of each robot under each classification, Basic Components of a Robotic System, Manipulator and Working, End-Effectors: Different Grippers and Tools, Applications of Industrial Robots, Disadvantages, Role of robots in CIM.

Automation: Automatic Guided Vehicles: Introduction, Simple AGV System, Components of AGV system, Types of AGVs - Automatic Storage and Retrieval System (ASRS): Definition, Objectives, Terms used in ASRS, Components of ASRS, Advantages of ASRS.

REFERENCE BOOKS:

Computer Integrated Design and Manufacturing, McGraw Hill – Bed worth David. D

Computer Integrated Manufacturing, PHI – Paul G. Ranky

Industrial Robotics, PHI – Gordon. N. Mair

Numerical Control And Computer Aided Manufacturing, TMH – T. K. Kundra, P.N. Rao

Computer Aided Manufacturing, TMH – T. K. Kundra, P.N. Rao CNC Machines, New Age – B.S. Pabla and M. Adithan

CAD, CAM, CIM -----BY Radha Krishnan.

SUGGESTED LEARNING OUTCOMES

On completion of the course the student should be able to

1. Understand the basic concepts of Computer aided Design (CAD) and Computer Aided Manufacturing

- 1.1. Appreciate the CAD
- 1.2. Identify advantages or Benefits of CAD
- 1.3. Identify different CAD softwares
- 1.4. List various CAD Input, Output and Display devices
- 1.5. Appreciate importance of Auto CAD as a CAD software
- 1.6. Familiar with the concept and need of networking
- 1.7. List the different types of communication networks and know the concept of each
- 1.8. Know the advantages and disadvantages of networks
- 1.9. Understand the importance of CAM
- 1.10. Identify the benefits and functions of CAM
- 1.11. Understand the concept of CAPP
- 1.12. Know the concept of Generative and Retrieval Process planning
- 1.13. Familiarize with the terms material requirement planning (MRP I) and manufacturing resources planning (MRP II) and advantages
- 1.14. Familiar with the block diagram of MRP-I
- 1.15. Familiar with the block diagram of MRP-II
- 1.16. Introduction to ERP and SAP
- 1.17. Identify the functions of CAM
- 1.18. Appreciate the advantages of CAM
- 1.19. Familiarize the Stages of CAM
- 1.20. Understand the concept of Computer Aided Process Planning(CAP)
- 1.21. Familiarize with the term computer integrated production system

2. Understand the Concepts of NC, CNC and DNC systems

- 2.1. Familiarize Numerical Control(NC)
- 2.2. List the features and advantages of NC

- 2.3. Identify the limitations of NC when compared to the conventional system
- 2.4. Understand the motion control in NC system
- 2.5. Familiar with the motion control system of NC: Point to point, continuous and contouring
- 2.6. Understand the chronology of developments of CNC and DNC systems
- 2.7. Illustrate the working principle of CNC system
- 2.8. Know the functions of each components of CNC system
- 2.9. Illustrate the working principle and advantages of DNC system
- 2.10. Know the specifications of CNC
- 2.11. Differentiate between NC, CNC & DNC systems

3. Familiar with the CNC Machines and Components and Attachments

- 3.1. Familiarize the term Machining Centre.
- 3.2. Identify the maintenance aspects of CNC machines
- 3.3. Appreciate the role of CNC in computer integrated manufacturing environment
- 3.4. Identify the various spindle drives
- 3.5. Appreciate the accuracy of Stepper and Servo motor
- 3.6. Illustrate slide ways
- 3.7. Familiarize with linear motion bearings, recirculatory ball screws
- 3.8. Familiarize the important components/attachments of CNC Machines
- 3.9. Appreciate the importance of automatic tool changer and its components.
- 3.10. Illustrate tool gripper and tool magazine
- 3.11. Identify the various feedback devices.
- 3.12. Know the Specification of Machining centre
- 3.13. Illustrate the constructional features of machining centres
- 3.14. Features of Automatic pallet changer
- 3.15. Working of linear and rotary transducer

4. Familiar with the CNC Part Programming concepts

- 4.1. Know the steps to write CNC part program
- 4.2. Understand the Absolute and Incremental CNC Co-ordinate systems
- 4.3. Understand the concept of Machine zero and Work zero referencing methods
- 4.4. Familiarize with structure of NC part program
- 4.5. Differentiate between manual and computer aided programming methods
- 4.6. Familiarize with G & M codes
- 4.7. Know the method of programming tool information, feed, speed data
- 4.8. Interpolation and types linear and circular
- 4.9. Write a part program in G & M codes.
- 4.10. Write part program for Facing, plain turning, taper turning and step turning
- 4.11. Identify the various programming cycles like simple turning cycle, peck drilling cycle, Grooving cycle, Boring cycle and thread cutting cycle.
- 4.12. Appreciate the importance of macros, sub routines, canned cycles.
- 4.13. Familiarize with APT programming

5. Understand the concepts of CIM, FMS and Additive Manufacturing

- 5.1. Define CIMS
- 5.2. Appreciate the necessity of CIMS
- 5.3. Appreciate the advantages of CIMS
- 5.4. Identify FMS as a sub set of CIMS
- 5.5. Identify the components of AGV's and ASRS
- 5.6. Illustrate the working of FMS
- 5.7. Identify the benefits of FMS
- 5.8. Appreciate the importance of coordinate measuring machine.
- 5.9. Illustrate the main features of CNC-CMM
- 5.10. Advantages of CNC-CMM
- 5.11. Know the concept of Additive Manufacturing (AM)
- 5.12. Know the necessity and use of AM
- 5.13. Familiarize the types of materials for AM
- 5.14. Understand the process or Steps in Additive manufacturing,
- 5.15. Classify the AM processes/3D Printing Processes,
- 5.16. State the basic concepts of AM Processes:
 - Vat Photo-polymerization / Stereolithography,
 - Material Jetting,
 - Binder jetting,
 - Material extrusion,
 - Powder bed fusion,
 - Sheet lamination,
 - Directed energy deposition,
- 5.17. Know the benefits of AM
- 5.18. Know the disadvantages of AM
- 5.19. Know the applications of AM
- 5.20. Understand the distinction between AM and CNC Machining.

6. Familiar with the fundamentals of Robots, Automated Storage and Retrieval Systems and Automated Guided Vehicles (AGVs).

- 6.1. Define a robot
- 6.2. Understand the necessity of robot
- 6.3. Understand the concept of Degree of Freedom of a robot
- 6.4. Classify robots and familiar with the each type under each classification
- 6.5. Identify the various components of a robotic system
- 6.6. Illustrate the working of a manipulator
- 6.7. Illustrate the types of end effectors
- 6.8. Familiar different types of Grippers (Mechanical, Magnetic and Vacuum type) and List the tools for specific purpose
- 6.9. Identify the applications of industrial robots
- 6.10. Appreciate the role of robots in CIMS
- 6.11. Know the Advantages and Limitations of Robots
- 6.12. Know the concept of AGVs with simple AGV system components
- 6.13. Familiar with the basic concept of different types of AGVs
- 6.14. Understand the basic concept and terms used in ASRSs system
- 6.15. Know the basic components of ASRS
- 6.16. Familiar with the advantages of ASRS

SUGGESTED E RESOURCES/STUDENT ACTIVITIES

- A Visit to a nearest Industry working on CNC Machines.
- Identify various machine tools including CNC and write the report differentiating an ordinary machine tool with CNC machine tool
- Write a part program for producing work pieces like round rods, stepper rods and screwed fasteners etc.
- www.nptel.ac.in
- www.coursera.com

Course Outcomes		CL	Linked PO	Teaching Hours
CO1	Understand the basic concepts of Computer aided Design (CAD) and Computer Aided Manufacturing	U/A	1,2,5,6,7	3
CO2	Understand the Concepts of NC, CNC and DNC systems	U/A	1,2,5,6,7	12
CO3	Familiar with the CNC Machines and Components and Attachments	U/A	1,2,5,6,7	6
CO4	Familiar with the CNC Part Programming concepts	A	1,2,3,4,6,7	6
CO5	Understand the concepts of CIM, FMS and Additive Manufacturing	U/A	1,2,3,4,5,6,7	3
CO6	Familiar with the fundamentals of Robots, Automated Storage and Retrieval Systems and Automated Guided Vehicles.	A	1,2,3,5,6,7	15

CO-PO Matrix

CO	PO1	PO2	PO3	PO4	PO5	PO6	PO7
1	1	3	-	-	3	1	2
2	1	3	-	-	3	1	2
3	3	3	-	-	3	3	3
4	1	3	2	1	-	3	3
5	1	1	1	1	1	1	1
6	2	2	1	-	3	2	2

QUESTION PAPER BLUE PRINT FOR CIE (MID I)

Unit No	Unit Name	Questions to be set for CIE (Q No)			Remarks
		R	U	A	
1	Introduction to Computer Aided Design and Manufacturing	1	5(a)	7(a)	
		2	5(b)	7(b)	
2	Introduction to NC, CNC and DNC Machines	3	6(a)	8(a)	
		4	6(b)	8(b)	

QUESTION PAPER BLUE PRINT FOR CIE (MID II)

Unit No	Unit Name	Questions to be set for CIE (Q No)			Remarks
		R	U	A	
3	CNC Machines and their Components	1	5(a)	7(a)	
		2	5(b)	7(b)	
4	CNC Part Programming	3	6(a)	8(a)	
		4	6(b)	8(b)	

ME-503

BOARD DIPLOMA EXANIMATIONS, (C21)

Model Paper
CAD /CAM
Mid Sem-I (CIE)

Time : 1 Hour

Total Marks : 20 M

PART – A

Marks: 4 X 1M = 4 M

*NOTE: Answer **all** questions and each question carries **one** mark.*

1. Define CAD
2. Define MRP-II.
3. Write one limitation of the NC System
4. What is the full form of DNC?

PART – B

Marks: 2 X 3M = 6 M

*NOTE: Answer **all** questions and each question carries **Three** marks*

5(a). List any three reasons for Networking

Or

5(b). List any three advantages of CAPP.

6(a). Explain Straight Cut motion control of NC.

Or

6(b) List any three limitations of NC over conventional machining.

PART – C

Marks: 2 X 5M = 10 M

*NOTE: Answer **all** questions and each question carries **Five** marks.*

7(a) List any five features of CAD packages.

Or

7(b) Explain the concept of SAP briefly.

8(a) Draw the Block Diagram of the CNC Machining system and label all the components.

Or

8(b) List any five advantages of DNC.

BOARD DIPLOMA EXANIMATIONS, (C21)

Model Paper

CAD /CAM

Mid Sem-II (CIE)

Time: 1 Hour

Total Marks : 20 M

PART – A

Marks: 4 X 1M = 4 M

*NOTE: Answer **all** questions and each question carries **one** mark.*

1. What is the full form of ATC related to CNC Machining?
2. Write the use of CNC Automatic Pallet Changer.
3. What is the meaning of the 'S2000' CNC word?
4. Mention the functions of G-Codes G00 and G01.

PART – B

Marks: 2 X 3M = 6 M

*NOTE: Answer **all** questions and each question carries **Three** marks*

5(a). Write any three CNC Machining center components

Or

5(b). Specify the function of the CNC Spindle drive

6(a). What is T-Word in CNC part programming?

Or

6(b) What is circular interpolation in the CNC part program?

PART – C

Marks: 2 X 5M = 10 M

*NOTE: Answer **all** questions and each question carries **Five** marks.*

7(a) Draw a neat sketch of Automatic Tool Changer (ATC).

Or

7(b) Write a short note on the following

i) Servo motor ii) Stepper motor

8(a) Briefly explain the Co-Ordinates Referencing Methods in CNC.

Or

8(b) Write the Steps Involved in CNC Part Programming.

BOARD DIPLOMA EXANIMATIONS, (C18)
SEMESTER END EXAMINATION (SEE)
Model Paper
CAD /CAM

Time: 2 Hours

[Total Marks: 40

PART-A

8X01=08

Instructions:

1. Answer **ALL** questions.
 2. Each question carries **ONE** mark.
1. Mention any three advantages of CAD.
 2. Define numerical control. What are the basic components of NC system?
 3. What is the full form of ASRS?
 4. What is the actuator of a Robot?
 5. FMS is best suited for?
 6. What is the necessity of Additive Manufacturing?
 7. What is a robot?
 8. What is the full form of AGV?

PART-B

04X03=12

Instructions: 1. Answer any **FOUR** questions.

2. Each question carries **THREE** marks.
9. (a) Explain various stages involved in design of a component using CAD.
(or)
 9. (b) Mention the importance of Computer Integrated Manufacturing System (CIMS).
 10. (a) How do you call a P2000 Subroutine repeating 6 times?
(or)
 10. (b) Classify the Robots as per the Degrees of Freedom.
 11. (a) Mention the importance of Computer Integrated Manufacturing System (CIMS)
(or)
 11. (b) List any three benefits of Additive Manufacturing.
 12. (a) Write a short note on SCARA Robot.
(or)
 12. (b) Write a short note on driverless trains.

PART-C

04X5=20

Instructions:

1. Answer any **FOUR** questions.
2. Each question carries **FIVE** marks.

13. (a) What is MRP-II? Explain in detail various functions of MRP-II.
(or)
13. (b) Illustrate the basic concept of Powder bed fusion Additive Manufacturing processes.
14. (a) Explain in detail the procedure involved in computer aided part programming.
(or)
14. (b) Draw a neat sketch of a Robot showing Six Degrees of freedom in motion
15. (a) Draw a Figure showing the application characteristics of FMS.
(or)
15. (b) List the steps involved in Additive manufacturing process.
16. (a) Classify the Robots as per the Workspace Geometry.
(or)
16. (b) Briefly explain the components of the AS/RS system.

ME-574- INDUSTRIAL ENGINEERING & ESTIMATION AND COSTING

Course Title:	Industrial Engineering & Estimation and Costing	Course Code:	ME-574
Semester:	V	Course group :	Core
Teaching Scheme(L:T:P):	4:1:0	Credits:	3
Methodolgy :	Lecture + Assignment	Total contact periods:	75
CIE:	60 Marks	SEE:	40 Marks

Prerequisites: Knowledge of Basic Sciences and Industrial Management.

COURSE OUTCOMES

On successful completion of the course, the students will be able to

Course Outcomes	
CO1	Explain the need of method study and work measurements
CO2	Explain wage payment methods and incentives and compare various merit-rating methods and
CO3	Express the importance of inspection and quality control and apply SQC tools in a given situation
CO4	Identify the constituents of Estimation and costing, and explain difference between Estimation and costing
CO5	Identify various overheads and compute selling price of a product, explain about depreciation, and Estimate the weight and cost of a material for a given product
CO6	Estimate the machining time and cost of Fabrication, Forging and foundry

Blue Print of Marks for SEE:

Units		No of periods	Questions to be set for SEE			Remarks	
			R	U	A		
Part-A	1. Work study-Method study, Work measurement	13	Q4	Q1	Q9(a)	Q13(a)	
	2. Wages & Incentives and Merit rating	12					
Part-B	3. Inspection, Statistical quality control	13		Q2	Q10(a)	Q14(a)	
	4. Fundamentals of Estimation & Costing	12					
Part-C	5. Estimation of Selling Price, Depreciation and weight of materials	13		Q3	Q5 Q6	Q9(b) Q11(a) Q11(b)	Q13(b) Q15(a) Q15(b)
	6. Estimation of Manufacturing Time and cost	12					
TOTAL		75		08	08	08	

COURSE CONTENT

- 1. Work study-** Meaning and purpose- Components of Work study-Productivity-Methods of improving Productivity

Method Study

Method study – purpose, Basic procedure for conduct of method study, Tools used: Outline process chart, Flow process chart, Two hand process chart, Micro motion study-Principles of Motion economy, Therbligs, SIMO Chart, Cyclegraph, Chronocyclegraph

Work measurement

Time study –Purpose, Basic procedure for conduct of Time study, Performance rating, Rating scales, Time allowances, Determination of Normal Time & standard time, Techniques of work measurement, Stop watch study, Procedure, PMTS, advantages, Work sampling, advantages, Simple problems on Work sampling.

2. Wages & Incentives and Merit Rating

Wage –Definition, types, causes for wage differentials, Standard Wage payment methods, Incentives-meaning, types-Methods of incentive payments-Halsey premium plan, Rowan plan, Emerson’s efficiency bonus system, Taylor’s differential piece rate system illustration, problems Merit rating-Definition, Objectives, Methods, Advantages-disadvantages.

3. Inspection & Statistical Quality Control

Inspection – objectives, Functions of inspection Department, Methods of inspection(No Explanation) . Quality control-necessity, variation in manufacture-assignable causes, chance causes, Quality characteristics-variables, attributes, Control charts for variables and attributes, advantages. Sampling plans-OC curve, illustration, importance, Single sampling plan, Double sampling plan, Difference between Control charts and sampling plans.

4. Fundamentals of Estimation & Costing

Estimation-objectives, Functions of estimation, qualities of estimator, Constituents of Estimation - design time, drafting, planning and production time, design and procurement, manufacture of special tools and equipment,labour,materials, overheads, miscellaneous expenses - estimation procedure

Costing– objectives, elements of costing viz., material, labour and expenses, Estimation and costing differences.

5. Estimation of Selling price, Depreciation and weight of materials

Prime cost, On cost(Expenses), Total cost of a product, Selling price of a product, Simple problems. Depreciation- Introduction, Causes of depreciation, Methods for calculating depreciation (No Explanation)- Sinking fund method illustration, Simple problems on sinking fund method. Estimation of weights – Principles of dividing the component drawing into simple and smaller geometrical configurations, Calculation of volume and the weight of the material, Estimation of cost of material, Problems on calculation of weights of material and material cost.

6. Estimation of Manufacturing Time

Estimation of machining time-Formulae for calculation of machining times for turning, drilling, simple problems on calculation of machining time for the above mentioned operations. Estimation of fabrication cost-Fabrication – types, cost of fabrication by gas welding and arc welding, Simple Problems

Estimation of forging cost-Components of forging cost, estimation of stock length, net weight, gross weight, estimation of stock size (No Problems)

Estimation of foundry costs--Components of foundry cost-cost of metal, cost of metal melting, moulding cost, core cost, cleaning cost, grinding and tooling cost.

REFERENCE BOOKS

1. Introduction to Work-study by ILO.
2. Work study by Ralph & Barnes
3. Industrial Engineering and Management, O.P. Khanna, Revised Edition, Dhanpat Rai Publications (P) Ltd.,
4. Industrial Engineering & Management Science by TR Banga
5. SQC by Juran
6. SQC by M.Mahajan.
7. SQC by Grant &Levenworth
8. Mechanical Estimating and costing by TR Banga, SC Sharma, Khanna Publishers.

ELECTRONIC RESOURCES

1. <https://nptel.ac.in/courses/>
2. <https://www.slideshare.net/>
3. <https://en.wikipedia.org/wiki/>
4. <http://ndl.ethernet.edu.et/bitstream/>

SUGGESTED STUDENT ACTIVITIES

1. Prepare a case study on productivity improvement by using Work study .
2. Identify various jobs in any organization and their pay.
3. Identify various quality control methods for daily used products .
4. Identify various administrative expenses in your institution.
5. Estimate the Total cost of a sheetmetal tray you done in the workshop.
6. Estimate the Forging cost of one experiment you done in the Forging shop

SUGGESTED LEARNING OUTCOMES

Upon completion of the course the student shall be able to

1. Work study-Method study, Work measurement

- 1.1. Define Work study, Method study, Work measurement.
- 1.2. Define productivity and methods of improving productivity.
- 1.3. State the objectives of Work study, Method study, Work measurement
- 1.4. State the advantages and disadvantages of Work study, Method study, Work measurement
- 1.5. Explain the Method study procedure.
- 1.6. Explain micro motion study in method study.
- 1.7. Explain Therbligs symbols
- 1.8. Use of various recording techniques
- 1.9. Explain Time study procedure
- 1.10. Illustrate performance rating and rating scales
- 1.11. Explain work measurement techniques

2. Wages & Incentives and Merit Rating

- 2.1. Define the term wage,
- 2.2. Explain types of wages
- 2.3. Explain Causes for wage differentials
- 2.4. Explain standard wage plans.
- 2.5. Define Incentive
- 2.6. List types of incentives.
- 2.7. Explain Methods of incentive payments-Halsey premium plan, Rowan plan, Emerson's efficiency bonus system, Taylor's differential piece rate system
- 2.8. Practice Problems to find incentives
- 2.9. State the purpose of merit rating

- 2.10. Explain the methods of merit rating a) Rating scale method b) Check list method c) Employee comparison method.
- 2.11. State the advantages and disadvantages of merit rating

3. Inspection & Statistical Quality control.

- 3.1. Define the term Inspection.
- 3.2. List different inspection methods
- 3.3. Explain the functions of inspection department
- 3.4. State the types of causes of variations –Assignable and Chance causes
- 3.5. Define Variable and attributes
- 3.6. State the objectives for X and R Chart
- 3.7. Construct control charts for variables and attributes charts in a given situation
- 3.8. Explain OC curve
- 3.9. Explain single sampling plan
- 3.10. Explain Double sampling plan
- 3.11. State the difference between control charts and sampling plans.

4 Fundamentals of Estimation and costing.

- 4.1. Definition of Estimation
- 4.2. Definition of costing
- 4.3. State Objectives of Estimation
- 4.4. Constituents of Estimation
- 4.5. Explain Qualities of a Estimator
- 4.6. Illustrate Constituents of Costing
- 4.7. Explain direct material cost and indirect material cost
- 4.8. Explain direct labour cost and indirect labour cost
- 4.9. Define various overheads with examples
- 4.10. Explain Difference between Estimation and costing

5 Estimation of selling price, depreciation, and weight of a material.

- 5.1 Define direct overheads and indirect overheads
- 5.2 Define Prime cost, factory cost, office cost, Total cost and selling price
- 5.3 Estimate the selling price of a given product
- 5.4 Define Depreciation,
- 5.5 Explain the terms book value ,scrap value, appreciation and depreciation
- 5.6 Explain Causes of Depreciation
- 5.7 List methods of Depreciation
- 5.8 Explain sinking fund method to find depreciation of a machine.
- 5.9 Compute Depreciation of a machine using sinking fund method.
- 5.10 Review of mensuration formulae for regular 2D figures including fillets, segments of circles

- 5.11 Review of mensuration formulae for regular 3D solids including solids of revolutions and segments
- 5.12 Principles of dividing the component drawing into simple and smaller geometrical configurations
- 5.13 Practice Simple problems on estimation of weights of various machine components

6 Estimation of Manufacturing time

- 6.1 Define machining time
- 6.2 Recall the meaning of cutting speed, feed, depth of cut
- 6.3 Practice simple problems on Estimation of machining time
- 6.4 Define Fabrication
- 6.5 List types of Fabrication
- 6.6 Estimate Fabrication cost of Gas welding
- 6.7 Estimate Fabrication cost of Arc welding
- 6.8 Define Forging
- 6.9 Explain components of Forging cost
- 6.10 Explain Estimation of Stock length net weight Gross weight and stock size
- 6.11 Define Foundry
- 6.12 Explain components of Foundry cost

COURSE OUTCOMES		CL	Linked POs	Teaching Periods
CO1	Explain the need of method study and work measurements	R, U, A	2,5,6	13
CO2	Explain wage payment methods and incentives and compare various merit-rating methods and	R, U, A	1,2,7	12
CO3	Express the importance of inspection and quality control and apply SQC tools in a given situation	U, A	2,6,7	13
CO4	Identify the constituents of Estimation and costing, and explain difference between Estimation and costing	U, A	1,5,7	12
CO5	Identify various overheads and compute selling price of a product, explain about depreciation, and Estimate the weight and cost of a material for a given product	U, A	1,2,7	13
CO6	Estimate the machining time and cost of Fabrication, Forging and foundry	R, U, A	1,2,7	12
			Total Periods	75

Legends: R = Remember; U= Understand; A= Apply and above levels (Bloom's revised taxonomy)

CO-PO Attainment Matrix:

COURSE OUTCOMES	PROGRAM OUTCOMES						
	PO1	PO2	PO3	PO4	PO5	PO6	PO7
CO1		3			1	2	
CO2	1	2					2
CO3		3				2	1
CO4	3				2		1
CO5	2	3					1
CO6	2	3					1

Level 3- Highly Addressed, Level 2-Moderately Addressed, Level 1-Lowly Addressed.

MID SEM-I EXAM

S.No	Unit Name	R	U	A	Remarks
1	1. Work study-Method study, Work measurement	1, 2	5(a) 5(b)	7(a) 7(b)	
2	2. Wages & Incentives and Merit rating	3, 4	6(a) 6(b)	8(a) 8(b)	
Total Questions		4	4	4	

MID SEM-I EXAM

S.No	Unit Name	R	U	A	Remarks
1	3. Inspection, Statistical quality control	1, 2	5(a) 5(b)	7(a) 7(b)	
2	4. Fundamentals of Estimation & Costing	3, 4	6(a) 6(b)	8(a) 8(b)	
Total Questions		4	4	4	

Legend	Remembering (R)	1 Mark
	Understanding (U)	3 Marks
	Application (A)	5 Marks

MID SEM-I
Model Paper :: ME-574
Industrial Engineering & Estimation and Costing

Time: 1 hr

Max. Marks:20

PART-A

4x1=4Marks

NOTE: 1) Answer all questions and each carries one mark.

2) Answers should be brief and straight to the point and shall not be exceed three simple sentences.

1. Write any two advantages of work study.
2. Define work measurement.
3. Define incentive.
4. List the different types of wage payment methods.

PART-B

2X3M=6

Marks

NOTE: 1) Answer all questions and each carries three mark.

2) Answers should be comprehensive and the criterion for valuation is the content but not length of the answer.

5. (a). What are therbligs? Give any two symbols of them.
5. (b). Distinguish between Method study and Time Study?
6. (a). Explain Halsey premium plan.
6. (b). Write three advantages of merit rating.

PART-C

2X5M=10

Marks

NOTE: 1) Answer all questions and each carries five mark.

2) Answers should be comprehensive and the criterion for valuation is the content but not length of the answer.

- 7.(a). Prepare Two hand process chart for assembly of nut and bolt.
- 7.(b). Define work sampling. State two advantages.
- 8.(a). List merit rating methods any Explain any one.
8. (b). Describe balanced or combined wage payment method.

MID SEM-II
Model Paper :: ME-574
Industrial Engineering & Estimation and Costing

Time: 1 hr

Max. Marks:20

PART-A

4x1=4Marks

NOTE: 1) Answer all questions and each carries one mark.

2) Answers should be brief and straight to the point and shall not be exceed three simple sentences.

1. Mention two advantages of inspection.
2. Define Variables?.
3. Define Estimation?
4. What are the elements that constitutes prime cost?

PART-B

2X3M=6

Marks

NOTE: 1) Answer all questions and each carries three mark.

2) Answers should be comprehensive and the criterion for valuation is the content but not length of the answer.

5. (a). State three objectives of \bar{X} and R charts.
5. (b). Write any three differences between single sampling plan and double sampling plan?
6. (a) Write the elements of Costing.
6. (b). Give three examples of overheads.

PART-C

2X5M=10

Marks

NOTE: 1) Answer all questions and each carries five mark.

2) Answers should be comprehensive and the criterion for valuation is the content but not length of the answer.

- 7.(a). Draw and explain the main characteristics of an OC curve.
- 7.(b). Write five functions of Inspection department
- 8.(a). Differentiate between estimating and costing.
8. (b) Briefly explain the estimating procedure.

BOARD DIPLOMA EXAMINATION, (C-21)
SEE-MODEL PAPER, ME-574
DME– V SEMESTER EXAMINATION
Industrial Engineering & Estimation and Costing

Time: 2 Hours

Max. Marks: 40

PART-A

8 X 1 = 8

- Instructions: 1. Answer ALL questions.
2. Each question carries ONE mark.
9. Define method study.
 10. List the methods of inspection
 11. Define depreciation.
 12. Define standard time.
 13. Write the formula to find the volume of Frustum of cone and sphere.
 14. Define factory cost.
 15. Write the formula to find stock size in forging.
 16. Write two indirect expenses in foundry.

PART-B

4 X 3 = 12

- Instructions: 1. Answer ALL questions.
2. Each question carries THREE marks.
10. (a) Write three advantages of Work measurement.
OR
 11. (b) Write five causes of depreciation.
 12. (a) Write three functions of inspection department.
OR
 12. (b) Write the components considered in estimation of foundry cost.
 13. (a) Write the procedure for estimating the weight of a material
OR
 13. (b) List various overheads and give one example of each.
 14. (a) Write the components considered for estimation of fabrication cost
OR
 14. (b) List the components considered for direct cost in foundry.

PART-C

4 X 5 = 20

- Instructions: 1. Answer ALL questions.
2. Each question carries FIVE marks.
15. (a) Explain any two recording techniques in method study.
OR
 - 13(b) The density of material for the part shown in figure is 8.5 gm/cc. Calculate the weight of the work piece and also the cost, if rate of material is Rs 30/kg.

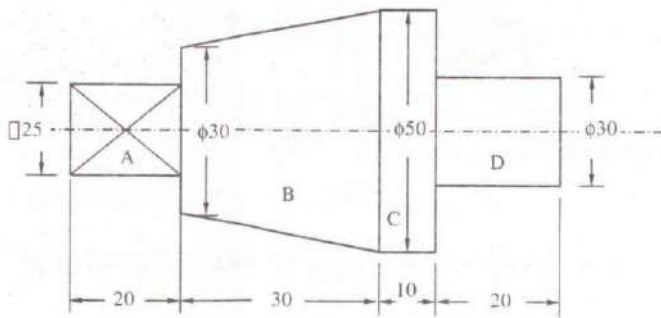

All Dimensions are in mm

14(a) Draw and Explain main characteristics of an OC (operating characteristic) curve

OR

14(b) Two 1m long M.S plates of 10mm thick are to be welded by a lap joint with the help of 6mm electrode. Assume the following data. Calculate the cost of welding.

- Current used = 250 amperes
- Voltage = 30V
- Welding speed = 10m/hr
- Electrode used = 0.5 Kg/m of welding
- Labour charges = Rs 15/hr
- Power charges = Rs 1per Kwh
- Cost of electrodes = Rs 15/ Kg
- Machine efficiency = 60%

15 (a) Define the terms book value, Scrap value, appreciation , depreciation and depreciation fund.

OR

15(b) A machine was purchased for Rs. 30,000/-. After 4 years, the value of the machine was estimated at Rs. 10,000. Find the depreciation using sinking fund method. The rate of interest being 5%.

16(a) Find the time required to turn 3.5 cm diameter bar to the dimensions shown in figure. Cutting speed is 15.4 m/min and feed is 1 mm/rev. All cuts are mm deep.

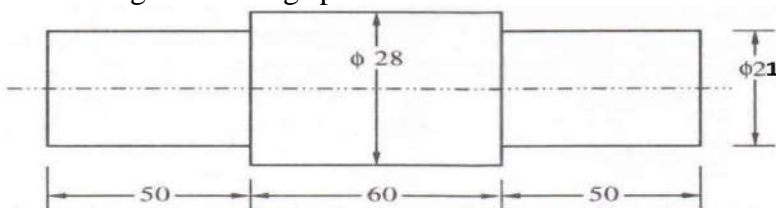

OR

16(b) Write the procedure for estimating the stock size in forging

ME-584-MECHATRONICS

Course Title:	Mechatronics	Course Code:	ME-584
Semester:	V	Course group :	Core
Teaching Scheme(L:T:P):	4:1:0	Credits:	3
Methodology :	Lecture + Assignment	Total contact periods:	75
CIE:	60 Marks	SEE:	40 Marks

Prerequisites: Knowledge of Basic Science and Engineering

COURSE OUTCOMES

On successful completion of the course, the students will be able to

CO1	Familiar with the classification and basic mechanisms of the Robots
CO2	Understand the various drive systems and sensors used in robotic systems
CO3	Understand the different Kinematics and Dynamics of Robots
CO4	Understand the concepts of Mechatronics System Models and Controllers
CO5	Know the basic PLC architecture and PLC programming concepts.
CO6	Understand the design examples of mechatronic system and also to know the condition monitoring of production systems using sensors

Blue Print of Marks for SEE:

Units		No of periods	Questions to be set for SEE				Remarks	
			R		U	A		
Part-A	1. Fundamentals of Robotics	12	Q4	Q1	Q9(a)	Q13(a)		
	2. Robotic Drive System and Controller	13						
Part-B	3. Sensors & Applications	12		Q2	Q10(a)	Q14(a)		
	4. Introduction to Mechatronics	13						
Part-C	5. Programmable Logic Controller (PLC)	13		Q3	Q5	Q9(b)		Q13(b)
	6. Design Examples in Mechatronics	12			Q6	Q11(a)		Q15(a)
				Q7	Q11(b)	Q15(b)		
				Q8	Q10(b)	Q14(b)		
					Q12(a)	Q16(a)		
					Q12(b)	Q16(b)		
TOTAL		75		08	08	08		

COURSE CONTENT

1. Fundamentals of Robotics:

Introduction; Definition; Robot anatomy (parts) and its working; Robot Components: Manipulator, End effectors; Construction of links, Types of joints; Classification of robots; Cartesian, Cylindrical, Spherical, SCARA, delta & articulated; Structural Characteristics of robots; Mechanical rigidity; Advantages and disadvantages of robots.

2. Robotic Drive System and Controller: Actuators; Hydraulic, Pneumatic and Electrical drives; Linear actuator; Rotary drives; AC servo motor; DC servo motors and Stepper motors; Conversion between linear and rotary motion; Robot controller; Level of Controller; Open loop and Closed loop controller; Microprocessor based control system; Robot path control: Point to point, Continuous path control and Sensor based path control.

3. Sensors & Applications:

Requirements of a sensor; Principles and Applications of the following types of sensors: Position sensors (Encoders, Resolvers, Piezo Electric); Range sensors (Triangulation Principle, Structured lighting approach); Proximity sensing; Force and torque sensing. Industrial Applications: Application of robots in machining; welding; assembly and material handling.

4. Introduction to Mechatronics:

Importance of Mechatronics; Systems: Measurement systems; Control systems and their types; Open and Closed-loop control Systems; Examples of Open loop and closed loop systems.

Mathematical Model:

Introduction to Mathematical model; Mechanical System building blocks; Electrical System building blocks; Fluid System building blocks; Thermal System building blocks.

System Model:

Engineering Systems: Rotational, Translational Systems; Electro-Mechanical System; Hydraulic and Mechanical Systems;

5. Programmable Logic Controller (PLC):

Definition; Basic block diagram and structure of PLC; Input/output processing; PLC Programming: Ladder diagram, its logic functions, Latching and Sequencing; PLC mnemonics; Timers; Internal relays and Counters; Shift registers; Master and Jump Controls; Data handling; Analog input/output; Selection of PLC, types of PLC

6. Design Examples in Mechatronics:

Design process stages; Traditional Vs Mechatronics designs; possible design solutions: Timed switch, Wind-screen wiper motion, Bath room scale; Case studies of Mechatronics systems: A pick-and-place robot, automatic car parking system, Car engine management system, Automatic Camera and Automatic Washing Machine only

Text Books:

1. Mikell P Groover, Nicholas G Odrey, Mitchel Weiss, Roger N Nagel, Ashish Dutta, "Industrial Robotics, Technology programming and Applications", McGraw Hill, 2012.
2. Craig. J. J. "Introduction to Robotics- mechanics and control", Addison- Wesley, 1999.
3. W.Bolton, "Mechatronics" , Pearson education, second edition, fifth Indian Reprint, 2003.
4. Smaili and F. Mrad, "Mechatronics- integrated technologies for intelligent machines", Oxford university press, 2008.

Reference Books:

1. Mechatronics – W. Bolton, Pearson Education India.
2. A Text Book on Mechatronics – R.K.Rajput, S.Chand&Co, New Delhi.
3. Exploring Programmable Logic Controllers with applications Pradeep Kumar Srivatsava, BPB Publications.
4. Michael B. Hstand and David G. Alciatore, " Introduction to Mechatronics and Measurement Systems", McGraw-Hill International Editions, 2000. D. A. Bradley, Dawson D., Buru N.C. and. Loader A.J, "Mechatronics", Chapman and Hall, 1993.
5. Dan Neculescu, "Mechatronics", Pearson Education Asia, 2002 (Indian Reprint).
6. Lawrence J. Kamm, "Understanding Electro – Mechanical Engineering", An Introduction to Mechatronics, Prentice – Hall of India Pvt., Ltd., 2000.
7. Nitaigour Premchand Mahadik, "Mechatronics", Tata McGraw-Hill publishing Company Ltd, 2003.

ELECTRONIC RESOURCES

1. <https://nptel.ac.in/courses/>
2. <https://www.slideshare.net/>
3. <https://en.wikipedia.org/wiki/>
4. <http://ndl.ethernet.edu.et/bitstream/>

SUGGESTED LEARNING OUTCOMES

1. Fundamentals of Robotics:

- 1.1. Know the history of robots & define the term robot
- 1.2. Understand the basic terminology related to Robots - Accuracy, Repeatability, Resolution, Degree of freedom.
- 1.3. Know the anatomy & basic components of a robot such as manipulator and end effectors.
- 1.4. Familiar with the Grippers-different methods of gripping, Mechanical grippers- Slider crank mechanism, Screw type, Rotary actuators, Cam type gripper, Magnetic grippers, Vacuum grippers, Air operated grippers; Specifications of robot.
- 1.5. Familiar with the construction of links in a robot.
- 1.6. Know the types of joints in a robot.

- 1.7. Understand the Classification of robots such as Cartesian, Cylindrical, Spherical, SCARA, delta & articulated
- 1.8. Understand the Structural Characteristics of robots.
- 1.9. Understand the concept of Mechanical rigidity
- 1.10. Familiar with the advantages and disadvantages of robots

2. Robotic Drive System and Controller:

- 2.1. Familiar with different Drive systems of the Robots like - hydraulic, pneumatic and electric systems
- 2.2. Familiar with different Actuators
- 2.3. Understanding the working of AC servo motor
- 2.4. Understanding the working of DC servo motor
- 2.5. Understanding the working of stepper motors
- 2.6. Familiar with the conversion between linear and rotary motion.
- 2.7. Familiar with the Robot controller & level of controller
- 2.8. Distinguish between Open loop and Closed loop controller
- 2.9. Understanding the microprocessor based control system
- 2.10. Familiar with different Robot path controls such as Point to point, Continuous path control and Sensor based path control.

3. Sensors & Applications:

- 3.1. Understand the functions of sensors in robots
- 3.2. Know about the requirements of a sensor.
- 3.3. Know about the classification of sensors.
- 3.4. Understanding the Principles and Applications of Position sensors (Encoders, Resolvers, Piezo Electric)
- 3.5. Understanding the Principles and Applications of Range sensors (Triangulation Principle, Structured lighting approach)
- 3.6. Understanding the Principles and Applications of Proximity sensors
- 3.7. Understanding the Principles and Applications of Force and torque sensors
- 3.8. Knowing about various applications of robot.
- 3.9. Familiar with the industrial applications of robots in machining & welding
- 3.10. Familiar with the industrial applications of robots in assembly and material handling

4. Introduction to Mechatronics:

- 4.1. Understanding the scope & importance of Mechatronics.
- 4.2. Familiarize with measurement systems.
- 4.3. Familiarize with control systems and their types; Open and Closed-loop control Systems; Examples of Open loop and closed loop systems.
- 4.4. Know the Mathematical Model of a system.
- 4.5. Know the Mechanical & Electrical System building blocks.

- 4.6. Know the Fluid & Thermal System building blocks.
- 4.7. List out the different Engineering System Models.
- 4.8. Understand the Engineering System Models such as Rotational, Translational Systems.
- 4.9. Understand the Engineering System Models such as Electro-Mechanical System.
- 4.10. Understand the Engineering System Models such as Hydraulic and Mechanical Systems.

5. Programmable Logic Controller (PLC):

- 5.1. Understand the basic definition of PLC
- 5.2. Be aware of the basic block diagram and structure of PLC
- 5.3. Understand the concept of Input/output processing
- 5.4. Familiarize basic PLC Programming
- 5.5. Be aware of Ladder diagram its logic functions
- 5.6. Familiarize Latching and Sequencing of PLC
- 5.7. Understand about mnemonics, Timers, Internal relays and Counters
- 5.8. Understand about Shift registers, Master and Jump Controls, Data handling & Analog input/output in PLC
- 5.9. Know the selection of PLC
- 5.10. Illustrate the different types of PLC

6. Design Examples in Mechatronics:

- 6.1. Familiarize the design process stages in Mechatronics
- 6.2. Understand the difference between Traditional Vs Mechatronics designs
- 6.3. Know the concept of timed switch, Wind-screen wiper motion and Bath room scale
- 6.4. Understand the case studies of Mechatronics systems: Pick-and-place robot
- 6.5. Understand the case studies of Mechatronics systems: Car park barrier
- 6.6. Understand the case studies of Mechatronics systems: Car engine management system
- 6.7. Understand the case studies of Mechatronics systems: Automatic Camera and
- 6.8. Understand the case studies of Mechatronics systems: Automatic Washing Machine

COURSE OUTCOMES		CL	Linked POs	Teaching Periods
CO1	Familiar with the classification and basic mechanisms of the Robots	R, U, A	1,2,4,7	12
CO2	Understand the various drive systems used in robotic systems	R, U, A	1,3,4,6,7	13
CO3	Understand the different sensors used in robotic systems & its industrial applications	R, U, A	1,2,3,4,7	12
CO4	Understand the concepts of Mechatronics System Models	R, U, A	1,4,7	13
CO5	Know the basic concepts about PLC	R, U, A	1,2,3,4,6,7	13
CO6	Understand the design examples of mechatronic system	R, U, A	1,2,3,4,7	12
Total Periods				75

Legends: R = Remember; U= Understand; A= Apply and above levels (Bloom's revised taxonomy)

CO-PO Attainment Matrix:

CO'S	PROGRAM OUTCOMES						
	PO1	PO2	PO3	PO4	PO5	PO6	PO7
CO1	3	1	-	2			2
CO2	3	-	1	2		1	2
CO3	3	2	1	1			2
CO4	3	-	-	2			3
CO5	3	-	1	2		1	2
CO6	3	2	1	2			2

Level 3- Highly Addressed, Level 2-Moderately Addressed, Level 1-Lowly Addressed.

MID SEM-I EXAM

Unit No	Unit Name	R	U	A	Remarks
1	Fundamentals of Robotics	1, 2	5(a) 5(b)	7(a) 7(b)	
2	Robotic Drive System and Controller	3, 4	6(a) 6(b)	8(a) 8(b)	
Total Questions		4	4	4	

MID SEM-II EXAM

Unit No	Unit Name	R	U	A	Remarks
3	Sensors & Applications	1, 2	5(a) 5(b)	7(a) 7(b)	
4	Introduction To Mechatronics	3, 4	6(a) 6(b)	8(a) 8(b)	
Total Questions		4	4	4	

**MID SEM - I
MODEL PAPER
MECHATRONICS (ME-584)**

Time: 1 Hours

Max. Marks: 20

PART-A

4 X 1 = 4

Instructions: 1. Answer **ALL** questions.

2. Each question carries **ONE** mark.

1. Define Robot.
2. What is a manipulator of a robot?
3. What is an actuator of a robot?
4. List out any two types of controllers.

PART-B

2 X 3 = 6

Instructions: 1. Answer **ALL** questions.

2. Each question carries **THREE** marks.

5. (a) Classify robots.
OR
5. (b) State advantages of robots.
6. (a) Distinguish between AC & DC servo motors.
OR
6. (b) How a linear motion can be converted into rotary motion.

PART-C

2 X 5 = 10

Instructions: 1. Answer **ALL** questions.

2. Each question carries **FIVE** marks.

7. (a) Explain briefly about Cartesian robot.
OR
7. (b) Explain briefly about end effectors of a robot.
8. (a) Briefly explain the working of a hydraulic driver.
OR
8. (b) Briefly explain about types of robot path control.

**MID SEM - II
MODEL PAPER
MECHATRONICS (ME-584)**

Time: 1 Hours

Max. Marks: 20

PART-A

4 X 1 = 4

Instructions: 1. Answer **ALL** questions.

2. Each question carries **ONE** mark.

1. What is a robot sensor?
2. What is an encoder?
3. Give any two examples of mechatronics system?
4. List out any two types of engineering system models.

PART-B

2 X 3 = 6

Instructions: 1. Answer **ALL** questions.

2. Each question carries **THREE** marks.

5. (a) Classify robot sensors. Give examples for each of them.
OR
5. (b) List out various industrial applications of robots.
6. (a) Distinguish between open and closed-loop control Systems.
OR
6. (b) How a linear motion can be converted into rotary motion.

PART-C

2 X 5 = 10

Instructions: 1. Answer **ALL** questions.

2. Each question carries **FIVE** marks.

7. (a) Explain briefly about Cartesian robot.
OR
7. (b) Explain briefly about end effectors of a robot.
8. (a) Briefly explain the working of a hydraulic driver.
OR
8. (b) Briefly explain about types of robot path control.

BOARD DIPLOMA EXAMINATION, (C-21)
SEE-MODEL PAPER
DME– V SEMESTER EXAMINATION
MECHATRONICS (ME-584)

Time: 2 Hours

Max. Marks: 40

PART-A

8 X 1 = 8

Instructions: 1. Answer **ALL** questions.

2. Each question carries **ONE** mark.

17. What is an 'end effector'.
18. List out ant two types of sensors.
19. What is a ladder diagram in PLC language?
20. What is the function of a linear actuator?
21. Give a simple example where latching is used in PLC.
22. What is the main function of PLC?
23. Give any two practical applications where mechatronics systems are involved.
24. What is the function of a timed switch?

PART-B

4 X 3 = 12

Instructions: 1. Answer **ALL** questions.

2. Each question carries **THREE** marks.

11. (a) List out different types of drives used in robots.
OR
13. (b) Write shot notes on data handling in PLC.
14. (a) What is the importance of mechatronics?
OR
14. (b) Briefly explain about Wind-screen wiper motion.
15. (a) Briefly explain the types of PLCs used in industries.
OR
15. (b) List out any three advantages of PLC control systems.
16. (a) List out the movements that are required for a pick-and-place robot.
OR
16. (b) Draw the block diagram of car engine management system.

PART-C

4 X 5 = 20

Instructions: 1. Answer **ALL** questions.

2. Each question carries **FIVE** marks.

17. (a) Explain briefly about robot anatomy and its working

OR

13. (b) Explain briefly about master and jump controls in PLC.

14. (a) Briefly explain about proximity sensing.

OR

14. (b) Explain various stages in designing mechatronics system.

15. (a) Explain the basic structure of a PLC with a block diagram

OR

15. (b) Explain the input/output processing in a PLC.

16. (a) Distinguish between traditional and mechatronics designs..

OR

(b) Explain the automatic car parking system using PLCs with a block diagram.

ME-575-FLUID POWER SYSTEMS

Course Title:	Fluid Power Systems	Course Code:	ME-575
Semester:	V	Course group :	Core
Teaching Scheme(L:T:P):	4:1:0	Credits:	3
Methodolgy :	Lecture + Assignment	Total contact periods:	75
CIE:	60 Marks	SEE:	40 Marks

Pre requisites

Basic Knowledge of hydraulics, pneumatics and control systems

Course Outcome

On successful completion of the course, the students will be able to attain below Course Outcome (CO):

Course Outcome	
CO1	Explain and Evaluate Hydraulic and Pneumatic Pump
CO2	Explain and differentiate Hydraulics motors
CO3	Describe the construction of various directional, Pressure and Flow control valves.
CO4	Hydraulic circuit design and Analysis.
CO5	Understand and explain Actuators
CO6	Design the single Actuator Circuits

Blue Print of Marks for SEE

Unit Name		Questions to be set for SEE Marks					Remarks		
		periods	R		U	A			
PART-A	Introduction to hydraulics and pumps	13	Q4	Q1		9(a)	13(a)		
	Hydraulic Motors and Actuators	12							
PART-B	Directional pressure and flow control valves	13		Q2		10(a)	14(a)		
	Hydraulic circuit design and analysis	12							
PART-C	Introduction to pneumatics and actuators	13		Q3		9(b) 11(a) 11(b)	13(b) 15(a) 15(b)		
	Single Actuator circuits	12						Q7 Q8	
TOTAL		75		10	8		06	06	

COURSE CONTENT

UNIT-I

Introduction to Hydraulics and Hydraulic pumps

Definition and scope of fluid power, Advantages and drawbacks of fluid power, Applications of fluid power, Components of Fluid power system - Hydraulic & Pneumatic systems Comparison between Hydraulic and Pneumatic Systems, Comparison of Different Power Systems - mechanical, electrical, hydraulic and pneumatic power systems, Future of Fluid power industry - in general and related to India. Classification of pumps based on Displacement, Delivery and Motion, Positive and Non-positive displacement pumps, Advantages and disadvantages of Non-positive displacement pumps Differences between Positive and Non positive displacement pumps, Classification of positive displacement pumps Pumping Theory, Gear pumps - External and internal gear pumps, Lobe and Screw pumps, Advantages, Disadvantages and applications of the above pumps, Vane pumps -Unbalanced and Balanced vane pumps, Advantages, Disadvantages and applications of vane pumps, Piston Pumps - Axial and Radial Piston Pumps Bent - Axis type and Swash - P Advantages, Disadvantages and applications of vane pumps, plate type piston pumps, Advantages, Disadvantages and applications of piston pumps, Volumetric and Mechanical efficiencies of pumps.

UNIT-2

Hydraulic Motors and Actuators

Introduction- Differences between hydraulic pump and motor, Applications of hydraulic motors, Comparison between hydraulic and electric motors, Classification of hydraulic motors, Gear motors, Vane motors, Piston motors, Theoretical torque, power and flow rate, Volumetric, Mechanical and Overall efficiencies of hydraulic motor. Introduction- Classification of actuators, Types of hydraulic cylinders – Single acting - Gravity return and spring return single acting cylinders, Double-acting - Piston rod on one side and both the sides, Telescope and Tandem cylinders, Cylinder force, velocity and power, First, Second and Third Class lever systems used in cylinders, Cylinder cushions and its importance.

UNIT-3

Directional, pressure and Flow control valves

Introduction to valves used in fluid power, Functions of direction control valves, Classification of direction control valves on different criteria, Classification of DCVs based on Fluid Path, Design Characteristics, Control Method, Construction of Internal Moving Parts, Symbols of various direction control valves, Different types of actuators - Manually operated, mechanically operated, Solenoid operated and Pilot operated actuators, Check valve – construction and operation details of Ball type, Poppet, Pilot operated and Solenoid actuated check valves, Two way and Three way control valves and their applications. Necessity and functions of pressure control valves, Classification of pressure control valves, Pressure relief valves - construction and working of simple and compound (pilot operated) pressure relief valves, Pressure reducing valves, Unloading valves - Direct Acting and Pilot operated unloading valves - construction and operation, Counter balance valves, Pressure sequence valves, Cartridge valves - Balanced and unbalanced poppet controlled cartridge valves, Applications of pressure control valves. Functions of flow control valves, Classification of flow control valves, Construction and operation of Non - pressure compensated and Pressure compensated flow control valves.

UNIT-4

Hydraulic circuit design and Analysis

Describing the operation of complete hydraulic circuits drawn using graphic symbols for all components, Control of single - acting hydraulic cylinder, Control of double - acting hydraulic cylinder, Regenerative cylinder circuit – expression for the cylinder extending speed, Load carrying capacity during extension, Pump unloading circuit, Double - pump hydraulic circuit, Counter balance valve application, Hydraulic cylinder sequencing circuit, Cylinder synchronizing circuits - cylinders connected in parallel and series, Fail - safe circuits, fail - safe system with overload protection, Two - handed safety system.

UNIT-5

Introduction to Pneumatics and Actuators

Introduction to Pneumatics, Choice working medium and system, Advantages and disadvantages of compressed air, Applications of pneumatics, Basic components of pneumatic systems, Advantages and disadvantages of pneumatic systems, Comparison of Mechanical / Electrical, Hydraulic and Pneumatic transmission systems Introduction to pneumatic actuators, Types of pneumatic actuators – Linear actuators (pneumatic cylinders), Rotary actuators (Air motors) and Limited angle actuators, Classification of Linear actuators based on, Application for which cylinders are used, cylinder's action, cylinder's movement and cylinder's design, Materials of construction for light, medium and heavy duty cylinders, Single acting cylinders - construction of Diaphragm cylinder, Rolling diaphragm cylinders, Gravity return and Spring return single acting cylinders, Construction of double - acting cylinders with piston rod on one side and both the sides, Telescopic cylinder, Tandem cylinder, Rodless cylinder, Cable cylinder, Sealing band Cylinder with slotted cylinder barrel, Cylinder with Magnetically Coupled Slide, Impact cylinders and Duplex cylinders, Graphic symbols of cylinders, Cylinder Seals - characteristics and classification, Static and Dynamic seals, Different types of cylinders used in cylinders, Working and applications of Air Motor.

UNIT-6

Single Actuator circuits.

Functions of the pneumatic circuits, Direct and indirect control of single acting cylinders, Control of single acting cylinder with OR, AND, NOT valves, Direct and indirect control of double acting cylinders, Control of double acting cylinders with Supply air - throttling, Exhaust air throttling, Time dependent controls - Time delay valve NC-type, Time delay valve NO-type.

REFERENCE BOOKS

1. Fluid power with applications by Anthony Esposito - Printice Hall of India
2. Fluid power control - NPTEL Web course
3. Pneumatics by SRIHARI RAO
4. Pneumatic controls by FESTO
5. Fluid Power Pneumatics by ALAN H. JOHN
6. Pneumatics by FLIPPO
7. Pneumatics By TTI
8. Hydraulics & Pneumatics by RAY & RAOd
9. Fluid Power & Pneumatics by AUDEL Series

E resources/ suggested student activities

1. <https://www.youtube.com/watch?v=YImRa-9zDF8> basics
2. <https://www.youtube.com/watch?v=8xd7cWvMrvE> nptel
3. <https://www.youtube.com/watch?v=p7kaKmw09g> practical examples
4. visit nearby JCB cranes, tippers and identify pneumatic devices and circuits and prepare a report about their working and their location.

SUGGESTED LEARNING OUTCOMES

On successful completion of the course the student shall be able to

1. Explain and Evaluate Hydraulics, Pneumatics and Pump

- 1.1 Explain the meaning of fluid power.
- 1.2 List the various applications of fluid power.
- 1.3 Differentiate between fluid power and transport systems.
- 1.4 List the advantages and disadvantages of fluid power.
- 1.5 Explain the industrial applications of fluid power.
- 1.6 List the basic components of the fluid power.
- 1.7 Explain the meaning of Pneumatics.
- 1.8 Differentiate between electrical, pneumatic and fluid power systems.
- 1.9 Appreciate the future of fluid power in India.
- 1.10 Classify the hydraulic pumps used in the industry.
- 1.11 Differentiate between positive displacement and non-positive displacement pumps.
- 1.12 Explain the working and construction of gear, vane and piston pumps.
- 1.13 Define mechanical, volumetric and overall efficiency of pumps.
- 1.14 Differentiate between internal and external gear pumps.

2 Explain and differentiate Hydraulics motors and actuators

- 2.1 Differentiate between a hydraulic motor and a hydraulic pump.
- 2.2 List various applications of hydraulic motor in fluid power.
- 2.3 Discuss various classifications of hydraulic motor.
- 2.4 Explain the construction and working of gear, vane and piston motors.
- 2.5 Explain various types of efficiency terms used in hydraulic motors.
- 2.6 Determine the torque and power delivered by hydraulic motors
- 2.7 Explain the classification of hydraulic actuators.
- 2.8 Explain various types of hydraulic cylinders.
- 2.9 Describe the construction and working of double-acting cylinders.
- 2.10 Derive an expression for force, velocity and power for hydraulic cylinders.
- 2.11 Analyze various lever systems using hydraulic cylinders.
- 2.12 Explain the importance of cylinder cushioning.

3 Describe and constructions of various directional, Pressure and Flow control valves.

- 3.1 List different types of valves used in fluid power.
- 3.2 Explain various classifications of directional control valves.
- 3.3 Describe the working and construction of various direction control valves.
- 3.4 Identify the graphic symbols for various types of direction control valves.
- 3.5 Explain the different applications of direction control valves.
- 3.6 Explain the working principle of solenoid-actuated valves.
- 3.7 Define valve overlap.
- 3.8 Evaluate the performance of hydraulic systems using direction control valves.

- 3.9 Explain various functions of pressure-control valves
- 3.10 Explain various classifications of pressure-control valves.
- 3.11 Describe the working construction of various pressure-control valves.
- 3.12 Differentiate between a pressure relief valve, a pressure-reducing valve, a sequence valve and unloading valve.
- 3.13 Identify the graphic symbols for various types of pressure-control valves.
- 3.14 Explain different applications of pressure-control valves.
- 3.15 Explain various functions of flow-control valves.
- 3.16 Explain various classifications of flow-control valves.
- 3.17 Describe the working and construction of various non-compensated flow control valves.
- 3.18 Differentiate between compensated and non-compensated flow-control valves.
- 3.19 Identify the graphic symbols for various types of flow-control valves.
- 3.20 Explain different applications of flow-control valves.

4. Hydraulic circuit design and Analysis.

- 4.1 Identify the graphic symbols for various types of hydraulic components.
- 4.2 Explain various hydraulic circuits to control single-acting and double acting cylinders.
- 4.3 Explain a regenerative circuit and determine the load-carrying capacities.
- 4.4 Describe the working of a double-pump circuit along with its advantages.
- 4.5 Explain the working of a sequencing circuit and a counterbalancing circuit.
- 4.6 Differentiate between series and parallel synchronization circuits.

5. Understand and explain Actuators.

- 5.1 Explain the meaning of Pneumatics
- 5.2 Describe the various properties desired of an air medium in pneumatic system
- 5.3 Explain the advantages and disadvantages of compressed air
- 5.4 Identify and appreciate the application of pneumatic systems in various Industries
- 5.5 List the basic components required for a pneumatic system
- 5.6 Describe the various power transmission systems
- 5.7 Compare hydraulic, pneumatic and mechanical systems.
- 5.8 Explain the meaning of Pneumatic Actuator
- 5.9 Classify the various types of Pneumatic actuators
- 5.10 Explain the working of various pneumatic actuators
- 5.11 Study the seals used in the Pneumatic actuators
- 5.12 Explain the working and application of air motors

6. Design the single Actuator Circuits.

- 6.1 Differentiate between pneumatic circuit and pneumatic circuit diagram
- 6.2 State basic rules used in design of pneumatic circuits
- 6.3 Explain the memory, delay, **OR**, **AND** and **NOT** functions
- 6.4 Explain the direct and indirect control of single acting cylinder

6.5 Explain the direct and indirect control of double acting cylinder

6.6 Differentiate supply and exhaust air throttling

6.7 Design pressure and time dependent circuits

Course Outcome			Linked PO	Teaching Periods
CO1	Explain And Evaluate Hydraulic and Pneumatic Pump	R, U, A	1,2,3,7	13
CO2	Explain and differentiate Hydraulics motors	R, U, A	1,2,3,7	12
CO3	Describe the construction of various directional, Pressure and Flow control valves.	U, A	1,2,3,7	13
CO4	Hydraulic circuit design and Analysis.	U, A	1,2,3,7	12
CO5	Understand and explain Actuators	U, A	1,2,3,	13
CO6	Design the single Actuator Circuits	R, U, A	1,2,3,7	12
		Total Sessions		75

○

Legends: R = Remember U= Understand; A= Apply and above levels (Bloom's revised taxonomy)

CO-PO Attainment Matrix:

COURSE OUTCOMES	PROGRAM OUTCOMES						
	PO1	PO2	PO3	PO4	PO5	PO6	PO7
CO1	3	2	2	-	-	-	1
CO2	3	2	3	-	-	-	1
CO3	3	2	3	-	-	-	
CO4	3	3	3	-	-	-	1
CO5	3	2	3	-	-	-	
CO6	3	3	3	-	-	-	1

Level 3- Highly Addressed, Level 2-Moderately Addressed, Level 1-Lowly Addressed.

MID SEM-1 EXAM
BOARD DIPLOMA EXAMINATIONS (C21)
MID SEM I, MODEL PAPER
Fluid Power Systems

Time : 1 Hours]

[Total Marks: 20

-
- Instructions :**
1. Answer **ALL** questions.
 2. Each question carries **ONE** mark.

1. What is the fluid transport system? 04x01=04 M
2. State two applications of fluid power in Automobiles.
3. Why is the actual torque output delivered by the hydraulic motor is less than the calculated theoretical torque?
4. What is the function of Hydraulic cylinder?

PART-B

02X03=06M

- Instructions :**
1. Answer any **TWO** questions.
 2. Each question carries **THREE** marks.
5. (a) Mention any three differences between hydraulic system and pneumatic system.
(or)
 5. (b) Define overall efficiency of a pump. Write an expression for overall efficiency.
 6. (a) State the advantages of Hydraulic motor over Electric motor.
(or)
 5. (b) What is meant by cylinder cushioning?

PART-C

- Instructions :**
1. Answer any **TWO** questions. 05X02=10M
 2. Each question carries **FIVE** marks.
7. (a) Explain the Classification of hydraulic pumps in fluid power systems.
(or)
 7. (b) Explain the working and construction of Vane pump.
 8. (a) Explain third class lever system used in hydraulic cylinder.
(or)
 8. (b) State the formulae for various efficiencies of a motor?

BOARD DIPLOMA EXAMINATIONS (C21)
MID SEM II
MODEL PAPER
Fluid Power Systems

Time : 1 Hours]

[Total Marks: 20

-
- Instructions :**
1. Answer **ALL** questions.
 2. Each question carries **ONE** mark.

1. State the function of a pneumatic valve. 04x01=04 M
2. List any two applications of flow control valves.
3. Draw the graphical symbol for cooler.
4. Draw the graphical symbol for cylinder - double acting.

PART-B

02X03=06M

- Instructions :**
1. Answer any **TWO** questions.
 2. Each question carries **THREE** marks.
5. (a) Explain various functions of pressure-control valves.
(or)
 5. (b) State the functions of flow control valve?
6. (a) Draw the graphic symbols for the following (i) Component enclosure (ii) Reservoir – Vented
(iii) Reservoir - Pressurized
(or)
 6. (b) What are the factors considered for designing hydraulic circuits?

PART-C

- Instructions :**
1. Answer any **TWO** questions. 05X02=10M
 2. Each question carries **FIVE** marks.
7. (a) Explain ball type check valve with neat sketch?
(or)
 7. (b) Explain the working principle of solenoid actuated valve.
8. (a) Explain the protection against over load circuit
(or)
 8. (b) Describe the working of a pump-unloading circuit using circuit diagram

BOARD DIPLOMA EXAMINATIONS (C18)
SEE-MODEL PAPER
DME– V SEMESTER EXAMINATION
Fluid Power Systems

Time : 2 Hours]

[Total Marks: 40

PART-A

08X01=08

- Instructions :**
1. Answer **ALL** questions.
 2. Each question carries **ONE** mark.
1. Define hydraulic rotary actuator.
 2. State the function of a check valve
 3. List the types of pneumatic actuators
 4. Write the classification of hydraulic motors.
 5. State the different power transmission systems.
 6. What is dynamic seal?
 7. State the basic rules used in design of pneumatics.
 8. State the function of pneumatic circuits.

PART-B

04X03=12

- Instructions :**
1. Answer any **FOUR** questions.
 2. Each question carries **THREE** marks.
9. (a) List out the types of hydraulic cylinders.
(or)
 9. (b) Write a short note on free air and standard air.
-
10. (a) Explain briefly functions of direction control valve.
(or)
 10. (b) Why Exhaust air throttling is used for speed control of the double acting cylinder ?
-
11. (a) State the rules followed in selection of working medium in fluid power system.
(or)
 11. (b) Write the advantages of pneumatic system
-
12. (a) State the rules used in design of Pneumatic circuits.
(or)
 12. (b) How does a **3/ 2** way valve work?

PART-C

04X5=20

- Instructions :**
1. Answer any **FOUR** questions.
 2. Each question carries **FIVE** marks.
 13. (a) Explain screw pump with a neat sketch.
(or)
 13. (b) What are the basic components of Pneumatic system? Explain their function
 14. (a) Describe the working of Double-Pump hydraulic system using circuit diagram.
(or)
 14. (b) Explain the Control of single acting cylinder with "NOT" valve.
 15. (a) Write briefly about advantages and disadvantages of compressed air.
(or)
 15. (b) State the specific applications of pneumatic systems in various industries.
 16. (a) Explain the direct control of double acting cylinder
(or)
 16. (b) Explain Exhaust air throttling?

ME-585-AUTOMOBILE ENGINEERING

Course Title:	Automobile Engineering	Course Code:	ME-585
Semester:	V	Course group :	Elective
Teaching Scheme(L:T:P):	4:1:0	Credits:	3
Methodolgy :	Lecture + Assignment	Total contact periods:	75
CIE:	60 Marks	SEE:	40 Marks

Prerequisites: Basic knowledge of Science, Work shop technology, Thermal engineering , theory of Machines

COURSE OUTCOMES

On successful completion of the course, the students will be able to

Course Outcomes	
CO1	Explain basic structure of Automobile and analyze Chassis, Frame and Engine
CO2	Analyze Transmission system of an Automobile
CO3	Analyze and construct Propeller Shaft and rear axle of an Automobile
CO4	Explain and illustrate front axle and steering system
CO5	Explain Suspension system and types of wheels& tyres
CO6	Explain braking system and classification of brakes

Blue Print of Marks for SEE:

Units		No of periods	Questions to be set for SEE				Remarks	
			R	U	A			
Part-A	1. Introduction & chassis, engine construction	12	Q4	Q1	Q9(a)	Q13(a)		
	2. Transmission system & clutches	13						
Part-B	3. Propeller Shaft and rear axle	12		Q2	Q10(a)	Q14(a)		
	4 Front Axle and Steering	13						
Part-C	5. Suspension systems and wheels and tyres	13		Q3	Q5	Q9(b)		Q13(b)
	6. Brakes	12			Q6	Q11(a)		Q15(a)
				Q7	Q10(b)	Q14(b)		
				Q8	Q12(a)	Q16(a)		
					Q12(b)	Q16(b)		
TOTAL		75	08		08	08		

COURSE CONTENT

1. Introduction to basic structure of Automobile- construction of Chassis and Frame

Introduction to various components of an automobile-functions of basic structure-transmission system, the auxiliaries, the controls and super structure -Chassis -various types of Chassis construction-the functions of frame- the loads on frame- frame construction with neat sketch- materials for frame-defects in frame- frameless construction with neat sketch

2. Transmission system & clutches

Introduction to transmission system- functions of transmission system- concept of total resistance to the vehicle motion- tractive effort-necessity of transmission- working of sliding mesh-synchromesh gear boxes-working of selector mechanism with gear lever on top of transmission case- lubrication of gear box- function of clutches- requirements of Clutch- brief description of components of Clutch-Mechanical operation of Clutch-main types of Clutches(friction Clutch and fluid clutch only)- principle of friction clutches-description and working of dry friction clutches- simple problems -working of Hydraulically operated single plate clutch

3. Propeller Shaft and rear axle

Functions of propeller shaft-construction of propeller shaft with neat sketch- various universal joints in automobile- the function and operation of a Differential in an automobile- general arrangement of a live rear axle- different loads on rear axle- different methods of supporting rear axle shafts with sketch-difference between semi-Floating and fully floating rear axle.

4. Front Axle and Steering system

Introduction to front Axle- types of stub axle- brief description of Elliot - Reverse Elliot-Lamoine -Reverse Lamoine -description of front wheel stub axle assembly- Steering system- Functions & Requirement of steering system. Construction and working of steering linkage – principle of correct steering angle(without mathematical analysis) simple equation- –steering geometry- camber, caster, toe-in, toe-out- details of Ackerman steering mechanism-Power steering

5. Suspension systems and wheels& tyres:

Need for good suspension system-elements of suspension system- different types of suspension springs- Leaf Springs-Helical Springs-construction of leaf spring - Construction & working of McPherson & wishbone suspension –Air Suspension System- Construction & working of Telescopic shock absorbers-Types of Automobile wheels, their construction & working- essential requirements of wheels - Construction, working & comparison of radial, cross-ply and tubed , tubeless tyre - Tyre specifications-Factors affecting tyre life-Wheel Alignment and Balancing.

6. Brakes

Requirements of automobile Brake-transfer of weight during braking operation- wheel skidding and techniques to prevent wheel skidding-various factors influencing braking effect-Classification of brakes- mechanical shoe brake with legible sketch- the layout of hydraulically operated four wheel brake system with simple diagram and it's working in detail-schematic diagram showing the layout of complete air brake system and explain it's working in detail. Internal expanding brake - Disc brake- Anti-lock braking system(ABS).

REFERENCE BOOKS

1. Automobile Engineering Vol I, II, Kirpal Singh, Standard Publishers Distributors, Delhi. 2012.
2. Automobile Mechanics, A.K. Babu, S.C. Sharma, Khanna Publications, New Delhi
3. Automobile Engineering R.B.Guptha –
4. Automobile Mechanics William Crouse Tata McGraw hill
5. Automotive Mechanics Joseph Hitner
6. Automotive Engineering, Jain and Asthana, Tata McGraw Hill.
7. Automotive Engineering-G.B.S Narang
8. Automobile Engineering- Kirpalsingh
9. Automobile Engineering- Rajput
10. The motor vehicle- Newton steeds & Garret
11. Automotive Chassis- P.M. Heldt.

SUGGESTED RESOURCES

1. Automatic Transmission System
https://www.youtube.com/watch?v=u_y1S8C0Hmc
2. Rack & Pinion Steering mechanism.
<https://www.youtube.com/watch?v=L41jg9h-S0>
3. Anti-lock braking system(ABS)

<https://www.youtube.com/watch?v=ru4JIZ-x8yo>

4. McPherson & wishbone .

<https://www.youtube.com/watch?v=oZz7RD7KRI0>

5. Wheel Alignment and Balancing.

https://www.youtube.com/watch?v=7d2K_mKgsZO

6. hydraulically operated four wheel brake system

<https://www.youtube.com/watch?v=82qBBJ8iwcc>

SUGGESTED STUDENT ACTIVITIES

1. Prepare list of various major automobile manufacturers of Two wheeler and four wheelers in India, along with their specification.
2. Prepare report on Top 10 Car/MUV/2W/Heavy vehicle Manufacturers in India & their sale in last 2 Years.
3. Collect the detail specification on Top 5 models of Car Manufactured in India
4. Download technical specifications/ catalogues, videos or any other suitable presentations on Automobile engines used in four wheelers
5. Download technical specifications/ catalogues, videos or any other suitable presentations on Automobile tyres/Power steering/Suspension system
6. Visit to four- wheeler service station & any automobile manufacturing unit. Prepare hand written report on aspects they observed in service station

SUGGESTED LEARNING OUTCOMES

Upon completion of the course the student shall be able to

1.0 Introduction to basic structure of an automobile

- 1.1 Explain various components of an automobile.
- 1.2 Define the basic structure, the power plant, transmission system, the auxiliaries, the controls and the superstructure of an automobile.
- 1.3 List types of Chassis construction.
- 1.4 Define functions of frame.
- 1.5 1.5 Define loads on frame.
- 1.6 Explain Frame construction with a neat sketch.
- 1.7 Write various materials for frames
- 1.8 Explain Sub frames and defects in frames.
- 1.9 Explain Frameless construction with a sketch.
- 1.10 Explain Engine construction with a neat sketch.
- 1.11 Explanation of stationary and moving parts of engine

2.0 Transmission system &clutches

- 2.1 Functions of transmission system.
- 2.2 Explain Concept of total resistance to the vehicle motion-Tractive effort-necessity of transmission.
- 2.3 State Working of sliding mesh-Constant mesh-Synchromesh gear boxes.
- 2.4 State Working of selector mechanism with gear lever on top of transmission case

- 2.5 Explain Lubrication of gear box.
- 2.6 Explain Functions of Clutches.
- 2.7 Know Requirements of Clutch.
- 2.8 Give Brief description of components of Clutch, clutch plate-clutch facing- pressure plate-springs-Bearings.
- 2.9 Know Mechanical operation of clutch.
- 2.10 Illustrate Main types of clutches (Friction clutch and fluid clutch only).
- 2.11 Understand Principle of friction clutches - Coefficient of friction, Axial pressure (w) and mean radius of contact surfaces(R).
- 2.12 Give Description and working of dry friction clutches-Single plate, multi plate.
- 2.13 Formulas for Torque transmission for uniform pressure and uniform wear criterion (without derivation)
- 2.14 Simple problems on single plate and multiplate friction clutches.
- 2.15 Understand Working of hydraulically operated single plate clutch

3.0 Propeller Shaft and rear axle

- 3.1 Explain the functions of propeller shaft.
- 3.2 Understand the construction of propeller shaft with a neat sketch.
- 3.3 Explain various universal joints in automobiles.
- 3.4 Analyze the function and operation of differential in an automobile.
- 3.5 Understand the general arrangement of a live rear axle.
- 3.6 Give different loads on rear axle.
- 3.7 Explain Different methods of supporting rear axle shafts with sketch.
- 3.8 Give the difference between semi-floating and fully floating rear axle.

4.0 Front Axle and Steering

- 4.1 Define front axle.
- 4.2 Explain Stub axle-ELLIOT-Reversed ELLIOT-LAMOINE-ReversedLAMOINE-brief description.
- 4.3 Description of front wheel stub axle assembly.
- 4.4 Explain Factors influencing of wheel alignment.
- 4.5 Understand Factors pertaining to wheels -Balance of wheels-Inflation of tyres -Brake adjustment-Concept of Steering geometry - Camber - Kingpin inclination - Combined angle - castor - Toe-in & Toe-out and their effects
- 4.6 Explain Steering linkage - principle of correct steering angle (without mathematical analysis) simple equation.
- 4.7 Give details of Ackerman steering mechanism.
- 4.8 Understand concept of cornering force-self righting torque.
- 4.9 Understand concept of under steering & over steering.
- 4.10 Understand concept of Rack & Pinion Steering mechanism-Power steering

5.0 Suspension systems wheels and tyres

- 5.1 Explain Suspension system.
- 5.2 Know the Need for good suspension system.
- 5.3 List elements of suspension system.
- 5.4 Explain Leaf Springs.

- 5.5 Explain Helical Springs.
- 5.6 Explain Construction & working of McPherson & wishbone.
- 5.7 Explain Construction & working of Telescopic shock absorbers.
- 5.8 List types of Automobile wheels.
- 5.9 Explain construction & working of different Automobile wheels.
- 5.10 Explain essential requirements of wheels .
- 5.11 Explain Construction, working & comparison of radial, cross-ply and tubed , tubeless tyre .
- 5.12 Give Tyre specifications.
- 5.13 Explain Factors affecting tyre life.
- 5.14 Explain Wheel Alignment and Balancing.

6.0 Brakes

- 6.1 Know the requirements of a automobile brake.
- 6.2 Understand the transfer of weight during braking operation.
- 6.3 Explain wheel skidding and describe techniques to prevent wheel skidding.
- 6.4 Explain various factors influencing braking effect.
- 6.5 Give Classification of brakes.
- 6.6 Understand mechanical shoe brake with a neat sketch.
- 6.7 Explain the layout of hydraulically operated four wheel brake system with a simple diagram and explain its working in detail.
- 6.8 Explain the schematic diagram showing the layout of complete air brake system and explain the working of its main units in detail.
- 6.9 Explain the working of disc brakes
- 6.10 Explain about ABS

CO1	Explain basic structure of Automobile and analyze Chassis, Frame and Engine	R, U, A	1, 2, 4,5,6, 7	13
CO2	Analyze Transmission system of an Automobile	R, U, A	1, 2, 4,5, 7	12
CO3	Analyze and construct Propeller Shaft and rear axle of an Automobile	U, A	1, 2, 4,5, 7	12
CO4	Explain and illustrate front axle and steering system	U, A	1, 2, 4,5, 7	13
CO5	Explain Suspension system and types of wheels& tyres	U, A	2, 4,5, 7	12
CO6	Explain braking system and classification of brakes	R, U, A	1, 2, 4,5, 6,7	13
			Total Periods	75

Legends: R = Remember; U= Understand; A= Apply and above levels (Bloom's revised taxonomy)

CO-PO Attainment Matrix:

COURSE OUTCOMES	PROGRAM OUTCOMES						
	PO1	PO2	PO3	PO4	PO5	PO6	PO7
CO1	1	2		3	2	2	3
CO2	1	2		3	2		3
CO3	1	2		3	2		3
CO4	1	2		3	2		3
CO5	1	2		3	2		3
CO6	1	2		3	2	2	3

Level 3- Highly Addressed, Level 2-Moderately Addressed, Level 1-Lowly Addressed.

MID SEM-I EXAM

S.No	Unit Name	R	U	A	Remarks
1	1. Introduction to basic structure of an automobile	1, 2	5(a) 5(b)	7(a) 7(b)	
2	2. Transmission system	3, 4	6(a) 6(b)	8(a) 8(b)	
Total Questions		4	4	4	

MID SEM-I EXAM

S.No	Unit Name	R	U	A	Remarks
1	3. Cooling and lubrication system	1, 2	5(a) 5(b)	7(a) 7(b)	
2	4. Steering system and Braking system	3, 4	6(a) 6(b)	8(a) 8(b)	
Total Questions		4	4	4	

Legend	Remembering (R)	1 Mark
	Understanding (U)	3 Marks
	Application (A)	5 Marks

MID SEM - I
MODEL PAPER
ME-585- AUTOMOBILE ENGINEERING

Time: 1 Hours

Max. Marks: 20

PART-A

4 X 1 = 4

- Instructions:** 1. Answer **ALL** questions.
2. Each question carries **ONE** mark.
7. Define piston?
 8. List two functions of piston rings
 9. What is the requirements of Clutch
 10. What is the purpose of Clutch

PART-B

2 X 3 = 6

- Instructions:** 1. Answer **ALL** questions.
2. Each question carries **THREE** marks.
11. (a) List various components of an automobile.
OR
5 .(b) What are different loads on frame.
 12. (a) List different types of gear boxes.
OR
6(b) What are the functions of transmission system.

PART-C

2 X 5 = 10

- Instructions:** 1. Answer **ALL** questions.
2. Each question carries **FIVE** marks.
- (7(a) Explain Engine construction with a neat sketch
OR
7(b) Explanation of stationary and moving parts of engine
 - 8(a) Explain Working of hydraulically operated single plate clutch
OR
8(b) Explain the working of Sliding mesh Gear box with a neat sketch

MID SEM - II
MODEL PAPER
ME-585- AUTOMOBILE ENGINEERING

Time: 1 Hours

Max. Marks: 20

PART-A

4 X 1 = 4

- Instructions:** 1. Answer **ALL** questions.
2. Each question carries **ONE** mark.
1. What is the function of a propeller shaft?
 2. What is differential?
 3. Define front axle?
 4. Write correct steering angle?

PART-B

2 X 3 = 6

- Instructions:** 1. Answer **ALL** questions.
2. Each question carries **THREE** marks.
5. (a) Give different loads on rear axle.

OR

5(b) what are Various universal joints in automobiles

6(a) List the functions of steering mechanism

OR

6(b) What are the requirements of steering mechanism

PART-C

2 X 5 = 10

- Instructions:** 1. Answer **ALL** questions.
2. Each question carries **FIVE** marks.
7. (a) Explain Different methods of supporting rear axle shafts with sketch.

OR

7(b) Give The difference between semi-floating and fully floating rear axle

8 (a) Explain Construction and working of Power Steering mechanism with a neat sketch.

OR

8(b) Explain Ackerman steering mechanism.

BOARD DIPLOMA EXAMINATION, (C-21)
SEE-MODEL PAPER
DME– V SEMESTER EXAMINATION
ME-585- AUTOMOBILE ENGINEERING

Time: 2 Hours

Max. Marks: 40

PART-A

8 X 1 = 8

- Instructions:** 1. Answer **ALL** questions.
2. Each question carries **ONE** mark.
1. List the different types of gear boxes.
 2. Define Kingpin inclination.
 3. List the elements of suspension system.
 4. List the types of Automobile wheels.
 5. List the factors affecting the tyre life.
 6. What is the Need for good suspension system.
 7. What is the requirements of a automobile brake.
 8. What is wheel skidding

PART-B

4 X 3 = 12

- Instructions:** 1. Answer **ALL** questions.
2. Each question carries **THREE** marks.

9(a). what are different types of Chassis construction

OR

9(b) . Explain tubed tyres.

10(a). Explain the construction of propeller shaft with a neat sketch

OR

10(b). list the types of Excavators.

11 (a) Explain telescopic shock absorbers

OR

11 (b) Explain the elements of suspension system.

12(a). Give Classification of brakes.

OR

12(b). Explain various factors influencing braking effect.

PART-C

4 X 5 = 20

- Instructions:** 1. Answer **ALL** questions.
2. Each question carries **FIVE** marks.

13 (a). Explain various components of an automobile.

OR

13 (b). explain wishbone suspension system.

14 (a) Explain working of Rack & Pinion Steering mechanism

OR

14 (b) Explain Anti-lock braking system.

15 (a) Explain McPherson suspension system..

OR

15 (b) Explain wheel alignment and balancing in a vehicle.

16 (a). Explain mechanical shoe brake with a neat sketch.

OR

16 (b) Explain wheel skidding and describe techniques to prevent wheel skidding.

ME-506-CAM LAB

Course Title:	CAM Lab	Course Code:	ME-506
Semester:	V	Course group :	Core
Teaching Scheme(L:T:P):	1:0:2	Credits:	1.5
Methodolgy :	Lecture + Assignment	Total contact periods:	45
CIE:	60 Marks	SEE:	40 Marks

Pre requisites

This course requires the basic knowledge of manufacturing process and Auto CAD

COURSE OUTCOMES

At the end of the course the students will have the ability:	
CO1	Identify the parts and functions of each component of CNC Lathe
CO2	To use incremental and absolute coordinate system on dimensioning understands different types of interpolation.
CO3	Familiar with the options/features available in the simulation software screen
CO4	Write a simple part program using G-Codes and M-Codes for various operations.
CO5	Execute a part program using CNC lathe machine simulation software
CO6	Write a part program using cycles as per the drawing and produce parts

OBJECTIVES

Up on the completion of the course the student shall be able to

1. Identify the parts and functions of CNC lathe
2. Use incremental system and absolute system on dimensioning.
3. Understand the meaning and usage of commonly used G & M codes for writing part program
4. Write a simple part program using G-Codes and M-Codes as per the given drawing/problem/ exercise
5. Edit and execute the part program using CNC simulation software.
6. Know the fixing of tools and operation of tool turret.
7. Know the tool offsetting and provide the same if necessary
8. Know the tool compensation and provide the same if necessary
9. Produce the part as per the drawing using CNC lathe machine.

COURSE CONTENT

1. Introduction to CNC
2. Study of each component of the CNC lathe machine
3. Understand the Structure of program and familiar with the important G – Codes and M- Codes/
4. Practice and knowing the options available in CNC Simulation softwares
5. Simple CNC operations: Facing and Turning
6. Turning exercise: Step turning using canned cycle
7. Turning exercise – Circular interpolation with CW and CCW
8. Turning Exercise - Taper turning and Peck drilling cycles
9. Thread cutting and Grooving exercises– Thread cutting and Grooving cycles

Note: The simulation software available in the market: FANUC, SIEMENS, HI NUMERIC, GSK etc.,

Suggested Learning Outcomes

Sl. No	Exercise	Key competencies expected
1	Hands on practice on CNC machine	Identify the various parts and switches Identification of orientation of CNC machine axis. Familiar the operate the various parts and knobs of the machine - Switch on /off Move the tool turret in Z & X axis direction. Index the tool turret Spindle off/on coolant on/off
2	Practice turning Operation on CNC machine	Use incremental system and absolute system of co-ordinate system Use appropriate tools for turning Select the speeds and feeds used for turning Select the depth of cut to be employed
3	Use G-Codes and M-Codes to write part program by understanding its structure	Identify the preparatory and miscellaneous functions of CNC Understand the meanings of various G-Codes and M-Codes Understand interpolation Understand the block numbers Understand various steps in the program
4	Practice with Simulation software	Understand the concept of simulation Practice the setting of software in simulation mode Open an existing part program Practice simulation for the program

5	Simple facing and turning operations	Write a part program to produce a part for Simple Facing operation. Write a part program to produce a part for Simple Turning operation. Write a part program to produce a part for Simple Taper turning operation. Write a part program to produce a part for Simple step turning operation.
6	Practice step turning canned cycle (Turning exercise)	Understand the canned cycle Write a part program to produce the part as per the given drawing Enter the program in the software Fix the job and set the tool Select proper cutting speed, depth of cut and feed for the given job Simulate the program and edit if necessary Execute the part program
7	Practice Turning exercise – Taper turning and Peck drilling Thread cutting and grooving	Select proper values of cutting speeds and feeds for taper turning and peck drilling Select proper values of cutting speeds and feeds for Thread cutting and grooving Write part program for Thread cutting and grooving cycles as per the given drawing

Course Outcomes		CL	Linked PO	Teaching Hours
CO1	Identify the parts and functions of each component of CNC Lathe	U/A	1,2,3,4,7	3
CO2	To use incremental and absolute coordinate system on dimensioning understands different types of interpolation.	U/A	1,2,3,4,7	12
CO3	Familiar with the options/features available in the simulation software screen	U/A	1,2,3,4,7	6
CO4	Write a simple part program using G-Codes and M-Codes for various operations.	A	1,4,7	6
CO5	Execute a part program using CNC lathe machine simulation software	U/A	1,2,3,4,5,7	3
CO6	Write a part program using cycles as per the drawing and produce parts	A	1,2,3,4,6,7	15

CO-PO MATRIX

CO	PO1	PO2	PO3	PO4	PO5	PO6	PO7	Mapping POs
CO1	3	1	1	3	-	-	3	1,2,3,4,7
CO2	3	1	1	2	-	-	3	1,2,3,4,7
CO3	3	1	1	2	-	-	2	1,2,3,4,7
CO4	3	-	-	2	-	-	2	1,4,7
CO5	3	1	1	2	1	-	1	1,2,3,4,5,7
CO6	3	2	3	3	-	1	2	1,2,3,4,6,7

Course-PO Attainment Matrix

Course Name	Program Outcomes (PO)						
	1	2	3	4	5	6	7
CAM Lab	3	2	2	3	--	--	3
Level 3- Highly Addressed, Level 2-Moderately Addressed, Level 1-Low Addressed							

BOARD DIPLOMA EXAMINATIONS

Model Paper

CAM LAB

Mid Sem-I (CIE)

Time: 1 Hour

Total Marks: 20 M

PART – A

Marks: 4 X 5M = 20 M

*NOTE: Answer **any four** questions and each question carries **Five** marks.*

1. Compare manual and computer aided par programming.
2. Define interpolation and types of interpolation
3. Write short notes on (a) Macros (b) Canned Cycles (c) APT.
4. Explain about coordinate systems and reference points in CNC Machines.
5. What are the types of statements used in APT programming and explain them.
6. What are preparatory and miscellaneous functions give examples each?

BOARD DIPLOMA EXAMINATIONS
CAM LAB
Mid Sem-II (CIE)

Time : 1 Hour

Total Marks : 20 M

PART – A

Marks: 2 X 10M = 20 M

NOTE: Answer any two question and each question 10 marks.

1. Write a CNC Program to reduce a billet of size 50 X 30 mm by turning to a size of 40 X 28 mm. Maximum depth of cut allowed 2 mm.
2. Write a program on manual facing to reduce into 25mm dia 70 mm length rod into 20 mm dia 65mm length. Maximum depth of cut allowed 1.5 mm.

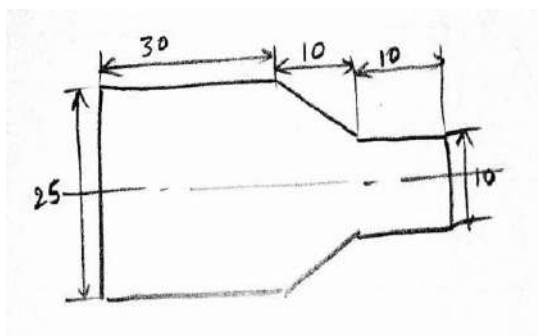

3. Write a program using G codes and M codes to reduce a billet of dia 60mm to dia 20mm in a step of 20mm

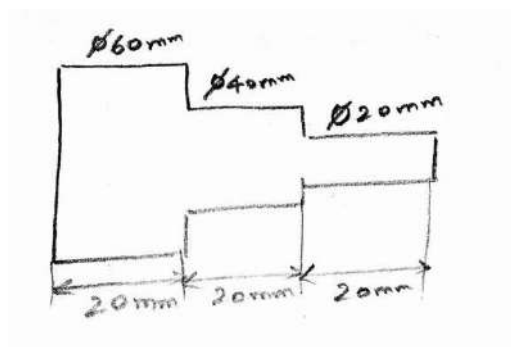

**BOARD DIPLOMA EXAMINATIONS
CAM LAB
SEMESTER END EXAM (SEE)**

Time : 2 Hour

Total Marks : 40 M

PART – A

Marks: 1 X 30M = 30 M

NOTE: Answer any one question.

1. Make the following job of aluminium billet of ϕ 40 mm & 80 mm long using turning operation on CNC machine.

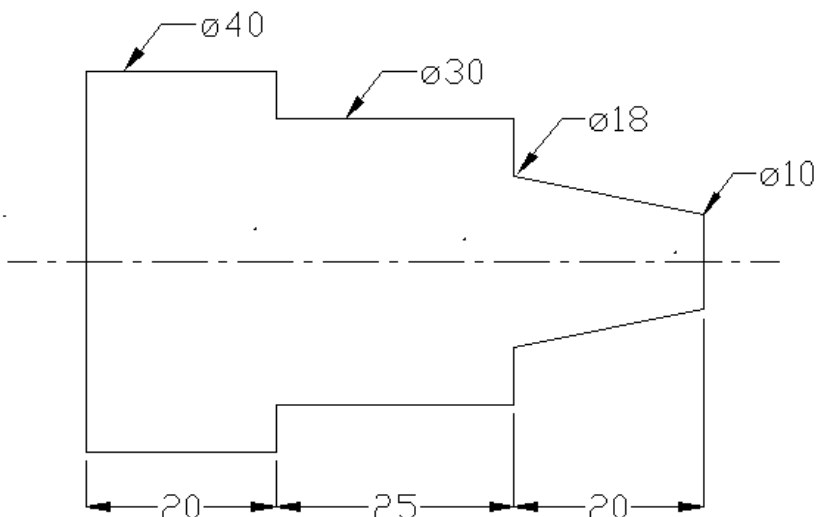

2. Make the following job of aluminium billet of ϕ 40 mm & 70 mm long using turning operation on CNC machine.

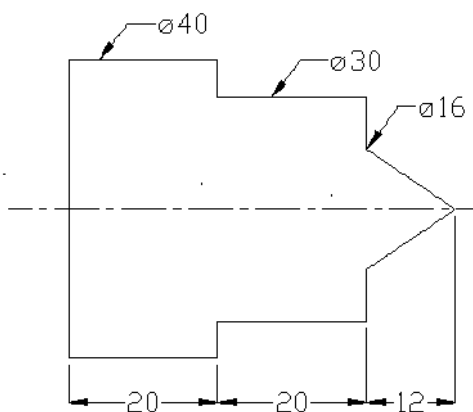

3. Make the following job of aluminium billet of ϕ 40 mm & 70 mm long using turning

operation on CNC machine.

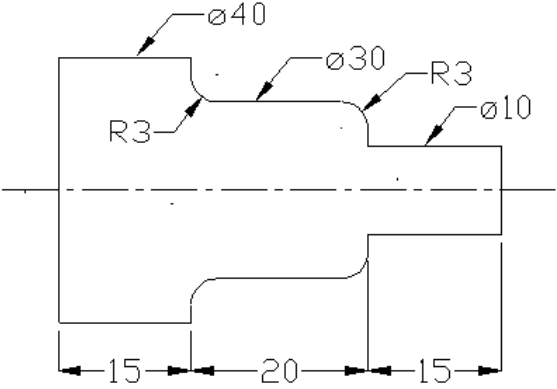

- 4. Make the following job of aluminium billet of $\phi 30$ mm & 60 mm long using turning operation on CNC machine

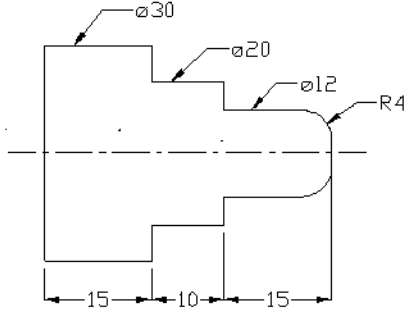

ME-507-ADVANCED MANUFACTURING & FABRICATION ENGINEERING LAB

Course Title :	Advanced Manufacturing & Fabrication Engineering Lab	Course Code	ME-507
Semester	V	Course Group	Core
Teaching Scheme in Periods(L:T:P)	1:0:2	Credits	1.5
Methodology	Lecture + Practical	Total Contact Periods:	45
CIE	60 Marks	SEE	40 Marks

Pre requisites This course requires the knowledge in basic manufacturing technology

Unit No	Unit name	Periods	Marks for SEE			Marks weightage	% Weightage
			Handl ing	Manipula tion	Preci sion		
1.	Practice on Lathe machine	12	10	15	15	40	100
2	Practice on Radial drilling machine	03	10	15	15	40	100
3	Practice on milling machine	06	10	15	15	40	100
4	Practice on shaping/planning	06	10	15	15	40	100
5.	Practice on slotting machine	03	10	15	15	40	100
6.	Hands on practice in welding	09	10	15	15	40	100
7.	Servicing and Maintenance	06	10	15	15	40	100
	Total	45					

Course outcomes

CO	Course Outcome	Mapping Pos
CO1	Ability to perform certain lathe operations like Thread cutting, Eccentric turning.	1,2,3,7
CO2	Ability to demonstrate and perform some operations on milling machine.	1,2,3,7
CO3	Ability to demonstrate and perform some operations on slotting, shaping machine	1,2,3,7
CO4	Ability to demonstrate and perform some operations on drilling machine	1,2,3,7
CO5	Ability to prepare angular joints and house hold articles using welding.	1,2,3,7
CO6	Knowing the importance of servicing and maintenance and importance of maintenance schedules	1,2,3,7

COURSE CONTENT

1. Machine shop

1.1 Turning

1.1.1 Thread cutting and eccentric turning

1.1.2 Drilling and boring.

1.1.3 Male and female fit assembly

1.2 Drilling

1.2.1 Drilling, Counter boring and counter sinking and Internal threading (tapping)

1.3 Milling / Shaping / Slotting / Planning

1.3.1 Gear Cutting on Milling Machine

1.3.2 T-slot cutting on milling machine

1.3.3 Produce V-Block on shaping machine

1.3.4 Key way cutting Slotting Machines

1.3.5 Practice on Planning machines

2. Welding

2.1 T. Joint

2.2 H – Joints

2.3 Angular joints.

2.4 Fabrication of any house hold item like stool, shoe rack etc.,

3. Servicing and Maintenance

3.1. Servicing of Lathe tail stock

3.2. Servicing of Chuck

3.3. Servicing of a machine like drilling or grinding etc.

SPECIFIC LEARNING OUTCOMES

Up on the completion of the course the student shall able to Practice the operations on the Lathe.

1.1. Calculate the gear ratio for thread cutting.

1.2. Cut threads on a lathe machine.

1.3. Produce articles of industrial application such as snap gauges, plug gauges,

1.4. Handle etc.

1.5. Perform the combination of operations to produce jobs.

1.6. Perform special turning operations to produce threaded objects, eccentric turning, and male and female fit assembly

- 2.0 **Understand various operations in machine shop**
- 2.1 Perform Cutting operation of V-block on shaping machine.
- 2.2 Practice the cutting operation on slotter
- 2.3 Practice the cutting operation on planer
- 2.4 Practice the principle of indexing on milling machine.
- 2.5 Perform gear Cutting and key way cutting operation on milling machine
- 3.0 **Practice the joining operations in Welding.**
- 3.1 Perform edge preparation and Weld the pieces to prepare T, H, and angular joints.
- 3.2 Produce utility articles such as shoe rack, garden chair, wash basins, stools etc
- 4.0 **Understand various operations of Drilling machine**
- 4.1 Perform various operation of Drilling machine like Drilling, Boring, counter
- 4.2 Bore, Counter sink and Tapping.
- 5.0 **Understand various activities in servicing and maintenance**
- 5.1. Use the testing and inspection methods of machine tools.
- 5.2. Dismantle and assemble the tailstock and chuck of lathe machine
- 5.3. Recondition the parts.
- 5.4. Service and overhaul machine of general nature.
- 5.5. Prepare maintenance schedules and estimates.

Key Competencies to be acquired by Students

S.No	Exercise	Key competency
Machine shop		
Turning		
1	Thread cutting	a. Center the job with dial gauge b. Fix the cutting tool in suitable angle c. Turn the component with suitable speed and feed d. Cut the threads with back gear arrangements
2	Eccentric turning	a. Fix the job in a chuck with correct eccentricity b. Fix the cutting tool in correct position c. Cut the metal with suitable speed and feed
	Drilling and boring.	<ul style="list-style-type: none"> • Center the job with dial gauge • Fix the drill in tail stock • Drill a hole to the required size by hand feed • Remove drill from tail stock and fix boring tool in tail stock • Bore a hole to an accuracy of $\pm 0.2\text{mm}$ with a tool
3	Male and female	a. Center the job with dial gauge

	fit assembly	<ul style="list-style-type: none"> b. Fix the cutting tool in suitable angle c. Turn the component with suitable speed and feed d. Locate the center of hole e. Select suitable drill bit f. Drill the hole with suitable speed and feed g. Enlarge the hole to suitable diameter by using boring tool
Milling/slott ing/planning		
1.	V-block on shaping machine.	<ul style="list-style-type: none"> a. Fix the job on shaping machine table b. Set the tool and give the table feed c. Set the stroke of the ram
2.	Key way cutting by slotting machine	<ul style="list-style-type: none"> d. Fix the job on slotting machine table e. Set the tool and give the table feed f. Set the stroke of the ram
3.	Indexing on slotting / milling machine	<ul style="list-style-type: none"> a. Identify of suitable indexing method b. Calculate revolutions of indexing crank c. Select index plate d. Select of hole circle
4.	T-slot cutting on milling machine	<ul style="list-style-type: none"> a. Identify T-slot cutter b. Exact setting of work-tool location
5.	Spur gear cutting on milling machine	<ul style="list-style-type: none"> a. Calculate no. of teeth on meshing gears for compound indexing b. Identify suitable HOB c. Select suitable holder for bevel gear blank

Drilling		
1	Drilling , Boring, Counter bore, Counter sink and Internal Threading	<ul style="list-style-type: none"> a. Fix the job on table with help of Vice/ T-Bolts b. Estimate the RPM and Feed c. Perform various operations d. To remove the drill bit from spindle with help of drift
Welding		
1	T-Joints, H- Joints, Angular Joints	<ul style="list-style-type: none"> a. Perform edge preparation b. Hold the electrode at suitable angle c. Identify the suitable Method of welding technique. d. Maintain proper distance between work piece and electrode tip produce arc. e. Check the weld bead
Servicing and Maintenance		
1	Tail stock and Chuck	<ul style="list-style-type: none"> f. Select the suitable tools with specification for dismantling. g. Dismantle the tail stock/ chuck h. Understand the operation of each part i. Know the cleaning and lubrication of parts j. Reassemble the tail stock/ chuck

CO-PO MATRIX

CO	PO1	PO2	PO3	PO4	PO5	PO6	PO7	Mapping Pos
CO1	3	3	3	-	-	-	1	1,2,3,7
CO2	3	3	3	-	-	-	1	1,2,3,7
CO3	3	3	3	-	-	-	1	1,2,3,7
CO4	3	3	3	-	-	-	1	1,2,3,7
CO5	3	3	3	-	-	-	1	1,2,3,7
CO6	3	3	3	-	-	-	1	1,2,3,7

State Board of Technical Education, Telangana State

Model Paper

ME-507- ADVANCED MANUFACTURING & FABRICATION ENGINEERING LAB

Mid Sem-I (CEE)

Time : 1 Hour

Total Marks : 20 M

Note: Answer any one question.

1. Cut a V thread on the given MS bar with given pitch
2. Prepare a male female assembly as per the given figure.
3. Produce a hole in MS round rod as per the given figure.
4. Prepare a T- joint as per the given figure.
5. Prepare a H- joint as per the given figure.
6. Prepare a angular joint as per the given figure
7. Prepare V Block on shaper
8. Prepare Spur gear on milling machine of given pitch.
9. Prepare Key way in a metal block on slotting machine.
10. Prepare 'T' slot in a metal block on milling machine
11. Dismantle the tail stock and reassemble after proper servicing
12. Dismantle the chuck and reassemble after proper servicing

- Note:**
1. For Mid sem 15 marks are to be awarded for conduct of experiment, 3 marks for record and 2 marks for Viva voice
 2. Exam should be conducted from the trade in which student undergone training only as classes are conducted on rotation basis.

State Board of Technical Education, Telangana State

Model Paper

ME-507- ADVANCED MANUFACTURING & FABRICATION ENGINEERING LAB

Mid Sem-II (CEE)

Time : 1 Hour

Total Marks : 20 M

Note: Answer any one question.

1. Cut a V thread on the given MS bar with given pitch
2. Prepare a male female assembly as per the given figure.
3. Produce a hole in MS round rod as per the given figure.
4. Prepare a T- joint as per the given figure.
5. Prepare a H- joint as per the given figure.
6. Prepare a angular joint as per the given figure
7. Prepare V Block on shaper
8. Prepare Spur gear on milling machine of given pitch.
9. Prepare Key way in a metal block on slotting machine.
10. Prepare 'T' slot in a metal block on milling machine
11. Dismantle the tail stock and reassemble after proper servicing
12. Dismantle the chuck and reassemble after proper servicing

- Note:**
1. For Mid sem 15 marks are to be awarded for conduct of experiment, 3 marks for record and 2 marks for Viva voice
 2. Exam should be conducted from the trade in which student undergone training only as classes are conducted on rotation basis.

State Board of Technical Education, Telangana State

Model Paper

**ME-507- ADVANCED MANUFACTURING & FABRICATION ENGINEERING LAB
(SEE)**

Time: 3 Hours

Total Marks: 40 M

Note: Answer any one question.

1. Cut a V thread on the given MS bar with given pitch
2. Prepare a male female assembly as per the given figure.
3. Produce a hole in MS round rod as per the given figure.
4. Prepare a T- joint as per the given figure.
5. Prepare a H- joint as per the given figure.
6. Prepare a angular joint as per the given figure
7. Prepare V Block on shaper
8. Prepare Spur gear on milling machine of given pitch.
9. Prepare Key way in a metal block on slotting machine.
10. Prepare 'T' slot in a metal block on milling machine
11. Dismantle the tail stock and reassemble after proper servicing
12. Dismantle the chuck and reassemble after proper servicing

Note: marks are to be awarded for conduct of Experiment, writing of procedure and viva voce

ME-508-REFRIGERATION AND AIR CONDITIONING LAB

Course Title	Refrigeration and Air Conditioning Lab	Course Code:	ME-508
Semester:	V	Course group :	Practical
Teaching Scheme(L:T:P):	1:0:2	Credits	1.5
Methodolgy :	Lecture + Assignment	Total contact periods:	45
CIE:	60 Marks	SEE:	40 Marks

Prerequisites: Basic knowledge of Thermodynamics and Refrigeration & Air conditioning

COURSE OUTCOMES

CO	On Successful completion of the course, the student will be able to
1	Evaluate Refrigeration and Air conditioning system tools and basic operations on soft copper tube
2	Identify and acquire knowledge on working of different parts of Refrigeration and Air conditioning systems.
3	Develop knowledge on refrigerants.
4	Measure Coefficient of Performance (COP) of Refrigeration and Air conditioning system with given data and use p-h chart.
5	Determine Coefficient of Performance (COP) of Refrigeration and Air conditioning systems.
6	Distinguish working of air cooler, water cooler, domestic refrigerator, split air conditioner and window air conditioner.

Course Content and Blue Print of Marks for SEE

	Unit name	Hours/ Periods	Marks for SEE			Marks weightage	% Weighta ge
			Handl ing	Manipul ation	Precis ion		
1.	R&AC Tools, Basic Operations on soft Copper tube	3	10	15	15	40	100
2.	Vapour Compression cycle test rig	6	10	15	15	40	100
3.	Water cooler	6	10	15	15	40	100
4	Air conditioning test rig	6	10	15	15	40	100
5	Domestic refrigerator	6	10	15	15	40	100
6	Window air conditioner	6	10	15	15	40	100
7	Split air conditioner	6	10	15	15	40	100
8	Air cooler	6	10	15	15	40	100
	TOTAL	45					

COURSE CONTENT

S.No	Refrigeration and air conditioning lab practice	Number of Periods
1	Familiarisation with Refrigeration and Air conditioning system Tools, Basic Operations on soft Copper tube	03
2	Experimental determination of COP of Vapour Compression cycle test rig	06
3	Experimentally determine COP of water cooler	06
4	Experimentally determine COP of air conditioning test rig	06
5	Experimentally determine COP of domestic refrigerator	06
6	Study of a window air conditioner	06
7	Study of a split air conditioner	06
8	Study of air cooler	06
Total		45

SUGGESTED LEARNING OUTCOMES

S.No	Exercise	Key competency
1	Familiarisation with Refrigeration and Air conditioning system Tools Basic Operations on soft Copper tube	<ul style="list-style-type: none"> a. Identify basic tools used in RAC b. Use the tools to perform flaring, swaging, bending and brazing operations
2	Experimental determination of Coefficient of Performance(COP) of Vapour Compression cycle test rig	<ul style="list-style-type: none"> a. Identify the components of vapour compression cycle test rig and draw line diagram b. Know the refrigerant used, its chemical formula and capacity of the plant c. Record the values of pressure and temperature when the pressure gauges are stabilized d. Record the energy meter reading e. Read the values from Pressure Vs Enthalpy diagram of the given refrigerant f. Evaluate COP
3	Experimentally determine Coefficient of Performance(COP) of water cooler	<ul style="list-style-type: none"> a. Identify the components of water cooler and draw line diagram b. Know the refrigerant used, its chemical formula and capacity of the plant c. Record the values of pressure and temperature when the pressure gauges are stabilized d. Record the energy meter reading e. Read the enthalpy values from Pressure Vs Enthalpy diagram of the given refrigerant f. Evaluate COP
5	Experimentally determine Coefficient of Performance(COP) of domestic refrigerator	<ul style="list-style-type: none"> a. Identify the components of domestic refrigerator and draw line diagram b. Record the values of pressure and temperature when the pressure gauges are stabilized c. Record the energy meter reading d. Read the enthalpy values from Pressure Vs Enthalpy diagram of the given refrigerant e. Evaluate COP

6	Study of a window air conditioner	<ul style="list-style-type: none"> a. Identify the components of window air conditioner and draw line diagram b. Know the refrigerant used, its chemical formula and capacity of the window air conditioner
7	Study of a split air conditioner	<ul style="list-style-type: none"> a. Identify the indoor unit and out door unit. b. Identify the components of split air conditioner and draw line diagram c. Know the refrigerant used, its chemical formula and capacity of the window air conditioner
8.	Study of air cooler	<ul style="list-style-type: none"> a. Identify the components of air cooler and draw line diagram b. Record the values of temperature of the room before and after switching on air cooler.

CO-PO Matrix

CO	PO1	PO2	PO3	PO4	PO5	PO6	PO7
CO1	2	-	-	3	1	-	2
CO2	2	-	1	2	1	-	3
CO3	2	-	-	2	1	-	2
CO4	2	1	1	2	-	-	3
CO5	2	1	1	2	1	-	2
CO6	1	-	-	2	2	-	2

COURSE OUTCOMES		CL	Linked POs
CO1	Evaluate Refrigeration and Air conditioning system tools and basic operations on soft copper tube	R, U, A	1,4,5,7
CO2	Identify and acquire knowledge on working of different parts of Refrigeration and Air conditioning systems.	R, U, A	1,3,4,5,7
CO3	Develop knowledge on refrigerants.	R, U, A	1,4,5,7
CO4	Measure Coefficient of Performance(COP) of Refrigeration and Air conditioning system with given data and use p-h chart.	U, A	1,2,3,4,7
CO5	Determine Coefficient of Performance(COP) of Refrigeration and Air conditioning systems systems.	U, A	1,2,3,4,7
CO6	Distinguish working of air cooler, water cooler, domestic refrigerator, split air conditioner and window air conditioner.	R, U, A	1,4,5,7

BOARD DIPLOMA EXAMINATIONS (C21)
Model Paper MID SEM - I
DME V SEMESTER EXAMINATION
REFRIGERATION AND AIR CONDITIONING LAB

TIME : 1 Hours

Max. Marks: 20

Answer any one question

1. List all basic tools used in RAC and identify them
2. Perform flaring and swaging operation on copper tube.
3. Perform brazing operation on given copper tube.
4. Determine COP of Vapour compression cycle from given data numerically
5. Determine COP of Vapour compression cycle from given data using p-h chart.
6. Identify all parts of water cooler and explain their function.
7. Determine COP of air conditioning test rig from given data numerically

BOARD DIPLOMA EXAMINATIONS (C21)
Model Paper MID SEM - II
DME V SEMESTER EXAMINATION
REFRIGERATION AND AIR CONDITIONING LAB

TIME : 1 Hours

Max. Marks: 20

Answer any one question

1. Identify all parts of domestic refrigerator and explain their function.
2. Determine COP of domestic refrigerator from P-h diagram.
3. Identify all major parts of window air conditioner and explain their function.
4. Identify all major parts of split air conditioner and explain their function.
5. Identify all major parts of window air conditioner and explain their function, record the change in temperature of room for every 5 minutes.

BOARD DIPLOMA EXAMINATIONS (C21)
Model Paper (SEE)
DME V SEMESTER EXAMINATION
REFRIGERATION AND AIR CONDITIONING LAB

TIME : 2 Hours

Max. Marks: 40

Answer any one question

1. List out all basic tools used in Refrigeration and Air conditioning system. Identify the tools and perform flaring and swaging operation on copper tube
2. List out all basic tools used in Refrigeration and Air conditioning systems. Identify the tools and perform brazing and swaging operation on copper tube
3. Determine COP of Vapour compression cycle from given data numerically
4. Determine COP of Vapour compression cycle from given data using p-h chart.
5. Determine COP of Vapour compression cycle from experimental data
6. Determine COP of water cooler from experimental data.
7. Determine COP of domestic refrigerator from experimental data.
8. Determine COP of air conditioning test rig from experimental data.
9. Identify all major parts of window air conditioner and explain their function.
10. Identify all major parts of split air conditioner and explain their function.
11. Identify all major parts of window air conditioner and explain their function, record the change in temperature of room for every 5 minutes.

SEE Question paper has to be prepared by Internal and External Examiners together.

ME-509- METROLOGY & PNEUMATICS LAB

Course Title:	Metrology & Pneumatics Lab	Course Code:	ME-509
Semester:	V	Course group :	Core
Teaching Scheme(L:T:P):	1:0:2	Credits:	1.5
Methodolgy :	Lecture + Assignment	Total contact periods:	45
CIE:	60 Marks	SEE:	40 Marks

Prerequisites: Basic knowledge of Metrology

COURSE OUTCOMES

On successful completion of the course, the students will be able to

Course Outcomes	
CO1	Measure various components of angle measurement using sine bar and bevel Protractor
CO2	Measure the geometrical dimensions of V-thread and spur gear
CO3	Understand the concepts of measurement of surface roughness, circularity, and roundness
CO4	Understand the direction and speed control of Single & double acting cylinder
CO5	To know the Control of a double-acting cylinder with OR logic
CO6	To know the Control of a Double-acting cylinder with AND LOGIC

LIST OF EXPERIMENTS

S.No.	Description	No of Periods
1	Introduction to Metrology	3
2	Measure the angle of the machined surface using a sine bar with slip gauges	3
3	To measure the screw thread parameters of a given specimen using Tool Maker's Microscope/Gear tooth vernier	6
4	Check the alignment using Autocollimator	3
5	Measurement of displacement using LVDT	3
6	Measurement of surface roughness using Talysurf tester	3
7	Introduction to Pneumatic components	3
8	Direct control of a single-acting cylinder	3
9	Direct control of a double-acting cylinder	3
10	Speed control of a double-acting cylinder	3
11.	Control of a double-acting cylinder with OR logic	6
12.	Control of a double-acting cylinder with AND logic	6
Total		45

REFERENCE BOOKS

1. Engineering Metrology – R. K. Jain
2. Engineering precision metrology – R. C. Gupta
3. A Handbook of Industrial Metrology – ASME
4. Measurement System (Application and Design) – Ernest O Doebelin
5. Pneumatics by SRIHARI RAO
6. Pneumatic controls by FESTO

SUGGESTED LEARNING OUTCOMES

Upon completion of the course, the student shall be able to

1. Introduction to Metrology

- 1.1. Understand the need and importance of Metrology in
- 1.2. Define metrology
- 1.3. Identify various measuring Instruments and their purpose.
- 1.4. Know the comparators and gauges

2. Measure the angle of the machined surface using a sine bar with slip gauges:

- 2.1. Identify various parts of the sine bar.
- 2.2. Understanding the usages of slip gauges
- 2.3. Understanding the method of finding out angel using sine bar
- 2.4. Knowing the formulae involving the calculation of the angle of any machined surface.

3. To measure the screw thread parameters of a given specimen using Tool Maker's Microscope/Gear tooth vernier:

- 3.1. Define various screw thread parameters
- 3.2. Identify various parts of the apparatus
- 3.3. Understanding the experimental setup
- 3.4. Understanding the method of finding out various screw thread parameters

4. Check the alignment using Autocollimator:

- 4.1. Understanding the concepts and necessity of alignment of parts/surfaces
- 4.2. Identify various parts of the apparatus
- 4.3. Understanding the experimental setup
- 4.4. Knowing the functionalities of Autocollimator

5. Measurement of displacement using LVDT:

- 5.1. Understanding the necessity of precision measurement of displacement
- 5.2. Identify various parts of the apparatus
- 5.3. Understanding the experimental setup
- 5.4. Understanding the method of finding out displacement using LVDT

6. Measurement of surface roughness using Talysurf tester:

- 6.1. Understanding the concepts of surface roughness and the necessity of measuring surface roughness
- 6.2. Identify various parts of the apparatus
- 6.3. Understanding the experimental setup
- 6.4. Understanding the method of finding out Measurement of surface roughness using Talysurf tester

7. Introduction to Pneumatic components

- 7.1. Understand the working of Pneumatic components.
- 7.2. Explain Pneumatics
- 7.3. Identify & List Symbols used in Pneumatic circuits.
- 7.4. Explain the phenomena of compressed air for transmitting power.
- 7.5. State Pascal's law.
- 7.6. List all the pneumatic applications.
- 7.7. Define Pneumatic actuator.
- 7.8. Classify the actuators.
- 7.9. Explain Linear actuators and Rotary actuators.
- 7.10. Define valve.
- 7.11. List different types of valves.
- 7.12. Explain the function of a valve.
- 7.13. Identify the components of a valve.
- 7.14. Identify ports and positions.
- 7.15. List the Applications of valves.

8. Direct control of a single-acting cylinder

- 8.1. Draw the circuit diagram for actuating a single-acting cylinder.
- 8.2. Select the suitable valve. eg: 3/2 valve.
- 8.3. Connect 3/2 valve to the actuator.
- 8.4. Actuate the single-acting cylinder by operating a 3/2 valve.

9. Direct control of a double-acting cylinder

- 9.1. Draw the circuit diagram for actuating a Double-acting cylinder.
- 9.2. Select the suitable valve.eg:4/2 valve.
- 9.3. Connect 4/2 valve to the actuator.
- 9.4. Actuate the double-acting cylinder by operating a 4/2 valve.

10. Speed control of a double-acting cylinder

- 10.1. Draw the pneumatic circuit for controlling the speed of double-acting cylinder
- 10.2. Select 4/2 or 5/2 valve and a throttle valve.
- 10.3. Connect 4/2 valve and throttle valve as per the circuit.
- 10.4. Operate the 4/2 valve and adjust the throttle valve to control the speed of the double-acting cylinder

11. Control of a double-acting cylinder with OR logic

- 11.1. Draw the pneumatic circuit for controlling the speed of double-acting cylinder using OR logic.
- 11.2. Select two 3/2 valves and a shuttle valve(OR Valve).
- 11.3. Connect 3/2 valves and OR valves to the double-acting cylinder as per the circuit.
- 11.4. Operate either one of the 3/2 valves to control the speed of double-acting cylinder.

12. Control of a Double-acting cylinder with AND LOGIC

- 12.1. Draw the pneumatic circuit for controlling the speed of double-acting cylinder using AND logic.
- 12.2. Select two 3/2 valves and AND valve.
- 12.3. Connect 3/2 valves and AND valves to the double-acting cylinder as per the circuit.
- 12.4. Operate two valves simultaneously to control the speed of double- acting cylinder.

COURSE OUTCOMES		CL	Linked POs
CO1	Measure various components of angle measurement using sine bar and bevel Protractor	R, U, A	1,2,4,5,6,7
CO2	Measure the geometrical dimensions of V-thread and spur gear	R, U, A	1,2,4,5,6,7
CO3	Understand the concepts of measurement of surface roughness, circularity, and roundness	R, U, A	1,2,4,5,6,7
CO4	Understand the direction and speed control of Single & double acting cylinder	U, A	1,2,3,4,5,6,7
CO5	To know the Control of a double-acting cylinder with OR logic	U, A	1,2,3,4,5,6,7
CO6	To know the Control of a Double-acting cylinder with AND LOGIC	R, U, A	1,2,3,4,5,6,7

Legends: R = Remember; U= Understand; A= Apply and above levels (Bloom's revised taxonomy)

CO-PO Attainment Matrix:

COURSE OUTCOMES	PROGRAM OUTCOMES						
	PO1	PO2	PO3	PO4	PO5	PO6	PO7
CO1	1	3	-	2	1	3	3
CO2	2	3	-	2	1	3	2
CO3	2	3	-	2	1	3	2
CO4	2	3	1	2	1	3	1
CO5	2	3	1	1	1	3	3
CO6	1	1	2	2	1	3	1

Level 3- Highly Addressed, Level 2-Moderately Addressed, Level 1-Lowly Addressed.

State Board of Technical Education, Telangana State
Model Paper
ME-509 – METROLOGY & PNEUMATICS LAB
Mid Sem-I (CIE)

Time : 1 Hour

Total Marks : 20 M

Note: Answer any one question.

1. Measure the angle of the machined surface using a sine bar with slip gauges.
2. Measure the screw thread parameters such as pitch, thread angle, and depth of screw of a given specimen using Tool Maker's Microscope/Gear tooth vernier
3. Check the alignment of a given specimen using Autocollimator.
4. Measure the displacement using LVDT.
5. Measure the surface roughness of a given surface using a Talysurf tester.
6. Connect pneumatic devices and control the direction of a Single acting Cylinder
7. Connect pneumatic devices and control the direction of a Double acting Cylinder
8. Connect the Pneumatic controls for Control of a double-acting cylinder with OR logic
9. Connect the Pneumatic controls for Control of a double-acting cylinder with AND logic
10. Connect pneumatic devices and control the speed of a Double acting Cylinder

Note: Exam should be conducted from the experiments in which students undergone training only as classes are conducted on a rotation basis.

State Board of Technical Education, Telangana State
Model Paper
ME-509 – METROLOGY & PNEUMATICS LAB
Mid Sem-II (CIE)

Time : 1 Hour

Total Marks : 20 M

Note: Answer any one question.

1. Measure the angle of the machined surface using a sine bar with slip gauges.
2. Measure the screw thread parameters such as pitch, thread angle, and depth of screw of a given specimen using Tool Maker's Microscope/Gear tooth vernier
3. Check the alignment of a given specimen using Autocollimator.
4. Measure the displacement using LVDT.
5. Measure the surface roughness of a given surface using a Talysurf tester.
6. Connect pneumatic devices and control the direction of a Single acting Cylinder
7. Connect pneumatic devices and control the direction of a Double acting Cylinder
8. Connect the Pneumatic controls for Control of a double-acting cylinder with OR logic
9. Connect the Pneumatic controls for Control of a double-acting cylinder with AND logic
10. Connect pneumatic devices and control the speed of a Double acting Cylinder

Note: Exam should be conducted from the experiments in which students underwent training only as classes are conducted on a rotation basis.

State Board of Technical Education, Telangana State
SEE Model Paper
ME-509 – METROLOGY & PNEUMATICS LAB

Time : 2 Hour

Total Marks : 40 M

Note: Answer any one question.

1. Measure the angle of the machined surface using a sine bar with slip gauges.
2. Measure the screw thread parameters such as pitch, thread angle, and depth of screw of a given specimen using Tool Maker's Microscope/Gear tooth vernier
3. Check the alignment of a given specimen using Autocollimator.
4. Measure the displacement using LVDT.
5. Measure the surface roughness of a given surface using a Talysurf tester.
6. Connect pneumatic devices and control the direction of a Single acting Cylinder
7. Connect pneumatic devices and control the direction of a Double acting Cylinder
8. Connect the Pneumatic controls for Control of a double-acting cylinder with OR logic
9. Connect the Pneumatic controls for Control of a double-acting cylinder with AND logic
10. Connect pneumatic devices and control the speed of a Double acting Cylinder

Note: Exam should be conducted from the experiments in which student undergone training only as classes are conducted on rotation basis.

ME-510-PROJECT WORK

Course title:	Project work	Course Code:	ME-510
Semester:	V	Course group:	Practical
Teaching scheme in periods (L:T:P):	1:0:2	Credits:	1.5
Methodology	Lecturer+Assignment	Total contact periods	45
CIE:	60 Marks	SEE:	40 Marks

Course outcomes:

The student should be able to

1. Apply principles of Mechanical engineering and Knowledge to solve problems of component with mechanical bias.
2. Demonstrate the knowledge to assess safety, legal issues and consequent responsibilities
3. To function effectively as an individual and as a member in a team
4. To communicate effectively
5. To engage in lifelong learning in the context of technological changes

VI SEMESTER

Sl. No	Subject	Items	Max Marks
1	Project work	CIE	
		1. Mid - I: Abstract submission – (Marks awarded by the Guide)	20
		2. Mid – II: Content development/ literature survey, data collection/prototype etc. - (Marks awarded by the Guide)	20
		3. Internal evaluation - (Marks awarded by the Guide)	20
		SEE	
		4.a) Final report Submission b) Seminar /Viva Voce (Marks awarded by the External Examiner, Head of Section (i.e. Internal Examiner) and Guide).	20 20
Total		100	

Note: The Project work carries 100 marks and pass marks are 50% and minimum of 50% in SEE. Internal assessment is done by guide and external assessment is conducted by guide, head of section and external examiner.

A candidate failing to secure the minimum marks has to reappear for the project.

COURSE CONTENT

- Identification and selection of a product with an aim to setup a small-scale industry.
- Conduct of detailed market survey.
- Preparation of production drawings.
- List of the raw materials, equipment and tools needed for manufacturing a specified quantity.
- Development of a prototype model of the product in workshop (if possible)
- with the available facilities in the Polytechnics.
- Exploration of the various financial arrangements to start the manufacturing of the product under technocrat scheme in small scale industrial sector.
- Detailed survey of requirements of the department of industry, municipal, health inspectorate of factories, electrical inspectorate, banks, other financial agencies etc., for starting an industry.
- Planning for type of organisation.
- Selection of site.
- Preparation of techno feasibility report consisting of production drawings, plant layout, building requirements, equipment requirement, list of raw materials and their availability, tools and other items, labour force requirement for production, ministerial staff requirement, material flow sheet, cash flow sheet, financial analysis etc.
- Working models, repairs, up gradation and maintenance of equipment.
- Product selection may be done by the Polytechnic in consultation with the local industries and other agencies.
- The student should submit techno feasibility report or model on a product selected with an aim to set up an industry in small scale sector.

Suggested learning outcomes

Upon completion of the course the student shall be able to

- **Prepare technical project report**
- Identify component with mechanical bias.
- Design and draw the production drawings.
- Prepare a project report with details of materials, processes etc.
- Develop a proto type/model of the product with the facilities available in polytechnic.
- **Conduct survey to establish a small scale unit**
- Identify and select a product with an aim to set up a small scale industry.

- Conduct a detailed market survey.
- List the raw materials, equipment and tools needed for the manufacture of a specified quantity.
- Explore the various financial arrangements to start the manufacture of a product under technocrat scheme in small scale industrial sector.
- Make a survey of requirements of the department of industries, municipal, health, inspectorate of factories for starting an industry.
- Plan for a type of organisation.
- Select a site.
- Prepare a techno feasibility report consisting of drawings, plant layouts, building requirements, machinery and equipment requirements, raw material, labour, production and administrative staff requirements, working capital, material flow sheet, cash flow sheet, financial analysis etc.
- Develop working models to show scientific and engineering principles studied in the curriculum and repair, up gradation and maintenance of equipment which are exist.

CO-PO Matrix

COURSE OUTCOMES	PROGRAM OUTCOMES						
	PO1	PO2	PO3	PO4	PO5	PO6	PO7
CO1	1	1		1	-	-	3
CO2	2	1	1	2	1	1	1
CO3	2	-	-	2	1	1	2
CO4	1	-	-	2	2	-	1
CO5	2	-	2	1	-	1	2

COURSE OUTCOMES		CL	Linked POs
CO1	Apply principles of Mechanical engineering and Knowledge to solve problems of component with mechanical bias.	R, U, A	1,2,4,7
CO2	Demonstrate the knowledge to assess safety, legal issues and consequent responsibilities	R, U, A	1,2,3,4,5,6,7
CO3	To function effectively as an individual and as a member in a team	R, U, A	1,4,5,6,7
CO4	To communicate effectively	U, A	1,4,5,7
CO5	To engage in lifelong learning in the context of technological changes	U, A	1,3,4,6,7

RUBRICS 1: Mid Sem - I

	GOOD	AVERAGE	ACCEPTABLE	UNACCEPTABLE
Identification of problem	Good explanation of the purpose and need of the project	average explanation of the purpose and need of the project	Moderate explanation of the purpose and need of the project	Minimal explanation of the purpose and need of the project
Study the existing systems	Collects a great deal of information and good study of the existing systems	Collects some basic information	Limited information	Incomplete information
Objectives and methodology	Good justification to the objectives	Incomplete justification to the objectives	Only some objectives of the proposed	Objectives of the proposed work are either not identified or not well

1. Identification of problem and explanation of the purpose and need of the project
2. Detailed study of the existing systems and feasibility of project proposal
3. Methodology and Abstract submission

RUBRICS2: Mid Sem II

	GOOD	AVERAGE	ACCEPTABLE	UNACCEPTABLE
Incorporation of suggestions	Changes are made as per modification	All changes are made as per modification	Few changes are made	Suggestions are not incorporated
Project demonstration	All defined objectives are achieved	All modules are achieved	Some of the defined objectives are achieved	Defined objectives are not achieved
Demonstration and presentation	Objectives achieved as per time frame	Objectives achieved as per time frame	Objectives achieved as per time frame	No Objectives achieved as per time frame

1. Changes are made as per modifications suggested and new innovations added
2. Complete explanation of the key concepts strong description of the technical requirements of the project
3. Objectives achieved as per time frame

ME-511-SKILL UPGRADATION

Course Title:	Skill Upgradation	Course Code:	ME-511
Semester:	V	Course group :	Practical
Teaching Scheme(L:T:P):	0:0:8	Credits:	2.5
Methodolgy :	Lecture + Assignment	Total contact periods:	120

ME-501

1. Prepare an organisational structure of institution
2. A Case study on principles of management.
3. Make a survey on marketing a product.
4. Prepare a list of ISO 9000 series as well as latest quality standards
5. Prepare sign boards representing safety measures.
6. Role play as an entrepreneur
7. A Case study on work study measurement.
8. Prepare job specifications and job description for a specific job.
9. Compare various job evaluation methods for a real example.
10. Calculate earnings of workers using various wage differentials
11. Prepare a cost statement using Excel sheet for real time problem.
12. Prepare an Excel sheet for fabrication data tables.

ME-502

1. Visit nearest outlet and list out Domestic Refrigerators manufacturers and
 - a. Know the capacity of the refrigerator and the refrigerant used in it.
 - b. Identify various tools and operations like swaging, flaring and brazing
 - c. Know the colour coding of refrigerant cylinders.
2. Make a report of Montreal and Kyoto protocols.
3. Assemble and disassemble the air cooler and know all the parts.
4. Clean an air cooler, replace pads of air cooler.
5. Visit a RAC workshop and watch the method of vaccumisation and charging of refrigerant.
6. Know the various operations in general servicing of Split AC like cleaning filters, cleaning of condenser coils, cooling coils and checking pressure of refrigerant
7. Perform one general servicing of AC
8. Visit a duct manufacturing unit and study how fabrication is done and submit a report.
9. Visit a site where ducting is being carried out.
10. Collect data sheet to find heating and cooling loads for an air conditioning system and study its contents.
11. Visit a site where split air conditioner is being installed.
12. Visit a central air conditioning plant.

ME-503

1. Visit a noted CAD center involved in commercial jobs and
 - a) Identify practically implemented CAD tools
 - b) Enquire opportunities for self employment in CAD / CAM industry
2. Visit nearby fabrication shop and identify one component and write CNC part programming by observing the geometrical shapes and dimensions and check by simulation

ME-584

1. Visit a nearby complete automation industry and observe following and present a seminar
 - a. How material is transported
 - b. How material is stored
 - c. How parts are inspected
 - d. How material is loaded onto machine
 - e. How material is loaded onto vehicles
 - f. Observe pick and place robots

ME-584

1. Visit a nearby Automobile servicing centre observe following and present a seminar
 - a. Observe dismantling of parts
 - b. Various tools used for dismantling and assembly
 - c. Steps in general servicing of parts
 - d. Washing of outside and inside of vehicle