

C24_CURRICULUM

DIPLOMA IN ELECTRONICS AND COMMUNICATION ENGINEERING



OFFEREDBY

**STATE BOARD OF
TECHNICAL EDUCATION & TRAINING,
TELANGANA: HYDERABAD**

I SEMESTER

S. NO	Course		Teaching Scheme					Examination Scheme						
	Code	Course Name	Instruction Periods per week			Total Periods per semester	Credits	Continuous Internal Evaluation (CIE)			Semester End Examination (SEE)			
			L	T	P			Mid Sem 1	Mid Sem 2	Internal Evaluation	Max marks	Min marks	Total Marks	Min marks for passing including internal
1	HU-101	Basic English	4	1	0	75	2.5	20	20	20	40	14	100	35
2	SC-102	Basic Engineering	4	1	0	75	2.5	20	20	20	40	14	100	35
3	SC-103	Basic Physics	4	1	0	75	2.5	20	20	20	40	14	100	35
4	SC-104	General Engineering Chemistry	4	1	0	75	2.5	20	20	20	40	14	100	35
5	EC-105	Basic Electronics	4	1	0	75	2.5	20	20	20	40	14	100	35
6	EC-106	Semiconductor Devices	4	1	0	75	2.5	20	20	20	40	14	100	35
7	ME-107	Engineering Drawing-I	1	0	2	45	1.25	20	20	20	40	20	100	50
8	EC-108	Basic Electronics Lab	1	0	2	45	1.25	20	20	20	40	20	100	50
9	SC-109	Basic Science Lab	1	0	2	45	1.25	20	20	20	40	20	100	50
10	CS-110	Computer Fundamentals Lab	1	0	2	45	1.25	20	20	20	40	20	100	50

HU-101 : BASIC ENGLISH

Course Title	Basic English	Course Code	HU-101
Semester	I	Course Group	Foundation
Teaching Scheme in Minutes (L:T)	3: 2	Credits	2.5
Methodology	Communicative Language Teaching + Assignments	Total Contact Hours	75
CIE	60 Marks	SEE	40 Marks

Prerequisites: Basic knowledge of English Language

COURSE CONTENTS

MODULE 1: VOCABULARY THROUGH READING - I

Duration: 15 Periods (L 9 P 6)

1. How to Learn a New Word
 - a. Spelling, pronunciation, syllabification, word class, inflections and the other forms of the word
 - b. Meanings, usage, derivatives, phrasal verbs, idiomatic expressions and context for using the word
 - c. Compound words, etymology, synonyms, antonyms and collocations.
2. Synonyms, Antonyms and One-Word Substitutes
3. Reading – I
 - a. Purpose of Reading
 - b. Types of Reading
 - c. Types of Paragraphs and Questions (Factual, Inferential, Vocabulary-based and Experiential)
4. Reading – II

Passages on Innovation, Science and Technology, History, Biography, Travel Writing, Nature Writing, Journal, Story, Process, Cause and Effect, Problem Solution, Evaluation of ideas, Reasons and Conclusion, etc.

MODULE 2: SPEAKING - 1

Duration: 10 Periods (L 6 P 4)

1. Need for English
2. Classroom English
3. Expressing Likes and Dislikes
4. Expressing Feelings

MODULE 3: GRAMMAR - I

Duration: 15 Periods (L 9 P 6)

1. Basic Sentence Structures
2. Tenses-I
3. Tenses-II
4. Voice

MODULE 4: SPEAKING – II

Duration: 10 Periods (L 6 P 4)

1. Introducing Oneself
2. Talking about daily routine
3. Fixing, Cancelling and Rescheduling Appointments
4. Extending, Accepting and Declining Invitations

MODULE 5: GRAMMAR - II

Duration: 15 Periods (L 9 P 6)

1. Adjectives
2. Prepositions
3. Asking Questions –I
4. Asking Questions - II

MODULE 6: WRITING - I

Duration: 10 Periods (L 6 P 4)

1. Paragraph Writing – I
2. Paragraph Writing – II
3. Letter Writing – I
4. Letter Writing – II

COURSE OUTCOMES

CO	At the end of the course, the students will have the ability to:
CO 1	Apply newly acquired vocabulary in contextually relevant scenarios, analyze provided passages for comprehension and formulate responses accordingly.
CO 2	Recall the uses of English, construct the frequently used sentences in classroom and express their likes, dislikes and feelings in different contexts.
CO 3	Construct various forms of sentence structures correctly and use different forms of tenses and suitable voice in various contexts.
CO 4	Introduce oneself, discuss one's daily routine, fix appointments and extend invitations.
CO 5	Describe objects using suitable adjectives, select the appropriate prepositions for different contexts and ask dichotomous and informative questions.
CO 6	Convey ideas in the form of paragraphs and compose formal and informal letters.

CO-PO Matrix

CO	PO 1	PO 2	PO 3	PO 4	PO 5	PO 6	PO 7	Mapping POs
CO 1	-	-	-	-	2	2	2	5, 6 and 7
CO 2	-	-	-	-	2	2	2	5, 6 and 7
CO 3	-	-	-	-	1	3	2	5, 6 and 7
CO 4	-	-	-	-	2	2	3	5, 6 and 7
CO 5	-	-	-	-	1	2	3	5, 6 and 7
CO 6	-	-	-	-	2	2	3	5, 6 and 7

CONTINUOUS INTERNAL EVALUATION (CIE)

Test	Modules	Marks	Pattern
Mid - I	1. Vocabulary Through Reading - I 2. Speaking- I	20	Part A: 4 short answer questions Part B: 2 short essay questions with internal choice Part C: 2 essay questions with internal choice
Mid - II	1. Grammar – I 2. Speaking- II	20	Part A: 4 short answer questions Part B: 2 short essay questions with internal choice Part C: 2 essay questions with internal choice
Slip Test - I	1. Vocabulary Through Reading - I 2. Speaking- I	5	2 questions out of 3 questions
Slip Test - II	1. Grammar – I 2. Speaking- II	5	2 questions out of 3 questions
Assignment	One assignment per one semester	5	Different assignments of higher order questions that develop problem solving skills and critical thinking should be given
Seminars	One seminar per one semester	5	Oral presentations using audio–visual equipment, charts, etc.
	Total	60	

MID EXAMINATIONS

MID SEM - I EXAM					
Sl. No.	Module	R	U	A	Remarks
1	Module - I	1, 2	5 (a) 5 (b)	7 (a) 7 (b)	
2	Module - II	3, 4	6 (a) 6 (b)	8 (a) 8 (b)	
Total Questions		4	4	4	

MID SEM - II EXAM					
Sl. No.	Module	R	U	A	Remarks
1	Module - III	1, 2	5 (a) 5 (b)	5 7 (a) 7 (b)	
2	Module - IV	3, 4	6 (a) 6 (b)	6 8 (a) 8 (b)	
Total Questions		4	4	4	

SEMESTER END EXAMINATION

SEMESTER END EXAM							
Sl. NO.	Module	Question to be set for SEE				Remarks	
		R		U	A		
1	I	4	1		9 (a)	13 (a)	
2	II						
3	III		2		10 (a)	14 (a)	
4	IV						
5	V		3		5, 6	9 (b)	13 (b)
						11 (a)	15 (a)
		11 (b)				15 (b)	
6	VI	3		7, 8	10 (b)	14 (b)	
					12 (a)	16 (a)	
					12 (b)	16 (b)	
Total Questions		8		8	8		

Legend:

Remembering: One mark
Understanding: Three marks
Application: Five marks

Suggested Student Activities:

- Practice conversation / dialogue / speech and answer the questions.
- Seminars.
- Review a movie.
- Narrate a story.
- Prepare chain stories.
- Vocabulary building games.
- Speak about incidents /events /memories /dreams/role model.
- Interviews of famous personalities.
- Collect the biographies of unsung heroes.
- Reading for main ideas and specific details.
- Describe pictures.
- Collect the letters written by famous persons and analyze them.
- Describing a process.
- Give directions using maps.

REFERENCES:

1. High School English Grammar & Composition by Wren & Martin
2. Practical English Grammar by A.J Thomson and A.V. Martinet
3. A Course in Phonetics and Spoken English by J. Sethi and P.V Dhamija
4. Word Power Made Easy by Norman Lewis.
5. Essential English Grammar by Raymond Murphy.
6. Spoken English-A Self Learning Guide to Conversation Practice by V. Sasi Kumar.

BOARD DIPLOMA EXAMINATION (C-24)
MID SEMESTER EXAMINATION -I
HU-101 BASIC ENGLISH

Time: One Hour

Total Marks: 20

PART - A

1 X 4 = 4 Marks

Instructions: a) Answer all the questions. b) Each question carries one mark.

1. Write a sentence each using the following words.
 - a. Report
 - b. Illustrate
2. Find one-word substitute for the following one.
A person who always looks at the brighter side of life.
3. Describe two qualities you dislike in your neighbour.
4. Write how you feel if you get selected for your college cricket team.

PART – B

2 X 3 = 6 Marks

Instructions: a) Answer the following questions. b) Each question carries three marks.

5. a) Read the following passage and answer the questions given below:
A dictionary serves as an efficient tool and forms the important reference material as a part of language learning. It provides spelling, pronunciation, stress and different connotations of the words in different contexts. Some dictionaries give etymology and word formation. A dictionary can be general or specialized, translating or giving lexical meanings within a single language. Dictionaries can assist the learning of vocabulary and is especially of great help to students who are learning a language.
 - a) What do dictionaries generally provide?
 - b) Find a synonym for 'origin of a word' from the passage.
 - c) How do dictionaries assist in learning a language?

(OR)

- b) Discuss any six ways of learning new vocabulary.
6. a) Explain any three problems one might face while learning English and suggest solutions to each of them.

(OR)

 - b) Express any three features you like and three features you dislike in your hostel.

PART – C

2 X 5 = 10 Marks

Instructions: a) Answer the following questions. b) Each question carries five marks.

7. a) Read the following passage and answer the questions given below it.

Dreams have always held a universal fascination. Some primitive societies believe that the soul leaves the body and visits the scene of the dream. Generally, dreams are accepted to be illusions, having much in common with day-dreams, the fantasies of our waking life. When dreaming, one tends to believe fully in the reality of the dream world, however inconsistent, illogical, and odd it may be. Although most dreams apparently happen spontaneously, dream activity may be provoked by external influences.

‘Suffocation’ dreams are connected with the breathing difficulties of a heavy cold, for instance. Internal disorders such as indigestion can cause vivid dreams, and dreams of racing fire-engines may be caused by the ringing of an alarm bell. Experiments have been carried out to investigate the connection between deliberately inflicted pain and dreaming. For example, a sleeper pricked with a pin perhaps dreams of fighting a battle and receiving a severe sword wound. Although the dream is stimulated by physical discomfort, the actual events of the dream depend on the associations of the discomfort in the mind of the sleeper.

- a). What may be the cause for the dream of racing fire-engines?
- b). What was the belief of primitive societies about the dreams?
- c). What happens when one is dreaming?
- d). Find a suitable word in the passage for the following phrases. “inability to breathe or feeling uncomfortable due to less air”
- e). What could be the actual reasons for getting dreams?

(OR)

b) Explain any five features of a new word that you wish to learn with the help of a dictionary. Give an example of each of those features.

8. a) Identify any ten problems that you face while learning English.

(OR)

b) Express any ten common sentences used by the teacher in the classroom.

BOARD DIPLOMA EXAMINATION (C-24)
MID SEMESTER EXAMINATION -II
HU-101 BASIC ENGLISH

Time: One Hour

Total Marks: 20

PART - A

1 X 4 = 4 Marks

Instructions: a) Answer all the questions. b) Each question carries one mark.

1. Write a sentence for the following sentence structure.
 - a) S + V
2. Change the following sentence into passive voice.
 - a) Pranav ate a mango.
3. Write a sentence for fixing an appointment with a general physician.
4. How do you invite your friend to play cricket with your team.

PART-B

2 X 3 = 6 Marks

Instructions: a) Answer all the questions. b) Each question carries three marks.

5. a) Fill in the blanks with the suitable verb forms:
 - i) My father _____(watch) TV when I entered house.
 - ii) Jahnvi _____ (go) to railway station before I went home.
 - iii) My brother _____(be) a good cricket player.
- (OR)
5. b) Change the following sentences into passive voice.
 - a) He plays cricket
 - b) Ramya has bought vegetables.
 - c) Balu is singing songs.
 6. a) You have recently joined the cricket academy. Introduce yourself to your new friends.

(OR)

6. b) You have an appointment with a general surgeon. Cancel the appointment with the doctor as you are suffering from fever.

PART-C

2 X 3 = 6 Marks

Instructions: a) Answer all the questions. b) Each question carries five marks.

7. a) Fill in the blanks with the suitable verb forms:

- i) My father _____(go) for a walk every day.
- ii) My sister _____ (buy) a book yesterday.
- iii) My brother _____(play) cricket for three hours.
- iv) The starts _____(be) bright.
- v) I _____(finish) my homework just now.

(OR)

7. b) Write a sentence each for the following sentence structures.

- a) S + V + SC
- b) S + V + O
- c) S + V + O + O C
- d) S + V
- e) S + V + D O + I O

8. a) Write about your daily routine in 10 sentences.

(OR)

8. b) Your brother's wedding is fixed. Extend the invitation to your favorite teacher.

Write a conversation between you and your teacher.

BOARD DIPLOMA END EXAMINATION (C-24)
SEMESTER END EXAMINATION
HU-101 BASIC ENGLISH

Time: Two Hours

Total Marks: 40

PART-A

1 X 8 = 8 Marks

Instructions: a) Answer all the questions. b) Each question carries one mark.

1. Write an antonym for the underlined word in the following sentence.
a) Ramya is a generous person who supported many charities for over 20 years.
2. Write a sentence using the following sentence structure.
a) S + V + O
3. Make 'Yes/No' question using the following statement.
a) He has come to college today.
4. A student does not know the meaning of a difficult word. How does he / she ask the teacher?
5. Fill in the blank with a suitable preposition.
a) He came to college _____ foot.
6. Identify the adjectives in the following sentences.
a) Srinivas has a costly watch.
b) Pavani sold a small bag to Radha.
7. Write any two salutations generally used in the formal letter.
8. Identify the central idea of the following paragraph.

An anecdote is a quick story about something of interest, usually with a singular theme or lesson. Anecdotes are no different than the stories told among friends, but when they're used in literature, they can accomplish more than merely passing the time.

PART-B

3 X 4 = 12 Marks

Instructions: a) Answer all the questions. b) Each question carries three marks.

9. a) How do you feel in the following situations?
 - i. India won the cricket world cup.

- ii. Your friend's grandmother passed away yesterday
- iii. Your sister did not return from college until late evening.

(OR)

b) Describe your friend using six suitable adjectives.

10 a) Change the following sentences into passive voice.

- i. Bees make honey.
- ii. Prasad stole my calculator.
- iii. I will complete my assignment tomorrow.

(OR)

b) Write a paragraph on your polytechnic in 50 words.

11. a) Change the following sentences into 'Wh' questions using the hints given in brackets

- i. I bought a camera yesterday. (Use 'what')
- ii. He was born in Sircilla on 28th December, 2002 (Use 'when')
- iii. He went to Hyderabad to buy books. (Use 'why').

(OR)

b) Fill in the blanks with suitable prepositions.

- i. He is suffering _____ fever.
- ii. His grandmother died _____ Covid-19.
- iii. He is good _____ mathematics.

12. a) Write a letter to your Principal requesting him / her to permit you to participate in the National seminar to be conducted in New Delhi.

(OR)

b) Write a paragraph in 50 words about your fresher's day party.

PART-C

4 X 5 = 20 Marks

Instructions: a) Answer all the questions. b) Each question FIVE mark.

13. a) Write any of the five aspects of learning a new word.

(OR)

b) Read the following passage and answer the questions given below.

I just returned from the greatest summer vacation. It was so fantastic. I never wanted it to end. I spent eight days in Paris. My best friends, Harish and Umesh came with me. We had a beautiful hotel room in the Latin Quarter, and it wasn't even expensive. We had a balcony with a wonderful view.

We visited many famous tourist places. My favorite was the Louvre, a well-known museum. I was always interested in art, so that was a special treat for me. The museum is so huge; you could spend weeks there. Harish got tired walking around the museum and said “Enough! I need to take a break and rest.”

We took lots of breaks and sat in cafes along the river Seine. The French food we ate was delicious. The fruits were tasty too. Umesh’s favorite part of the vacation was the hotel breakfast. He said he would be happy if he could eat tartines like those forever. We had so much fun that we’re already talking about our next vacation!

- a) Which city did they visit for summer vacation?
- b) How long was the summer vacation?
- c) What did their hotel room have?
- d) Who got tired walking in the Louvre Museum?
- e) What did Umesh enjoy the most?

14. a) Write your mother’s daily routine in 100 words.

(OR)

b) Write a letter to the newspaper editor about the problem of street dogs in your colony.

15. a) Frame two ‘Yes/No’ questions and three ‘Wh’ questions from the following passage.

For a year Gopal Krishna Gokhale studied in the Deccan College, Poona. Then he went to Elphinstone College, Bombay, for his final B.A. There he took mathematics as an optional subject and eventually became interested in it. He came under the influence of a distinguished English professor who further quickened his interest in his studies. Under this professor’s guidance he made so much progress that he gained a scholarship of twenty rupees a month. It was not a small sum for him who had always been poor. The scholarship was a veritable boon to him made him very happy.

In 1884 he took his B.A. in the second division. He then joined the College of Science and Engineering at Poona. A short time after doing so, he learnt that he

could study law in the Deccan College. But he did not know how to do it, because he wanted to earn his living while he was a student. Soon an opening offered itself to him. He was appointed a teacher in the New English School, Poona, on thirty-five rupees a month. He made up his mind to take the law course while working as a teacher.

(OR)

b) Describe your mobile phone using at least ten adjectives in 100 words.

16. a) Write a paragraph on different types of pollution in 100 words.

(OR)

b) Write a letter to your school friend sharing your experiences at your polytechnic.

SC-102 : BASIC ENGINEERING MATHEMATICS

Course Title	Basic Engineering Mathematics	Course Code	SC-102
Semester	I	Course Group	Foundation
Teaching Scheme in Periods (L : T : P)	4:1:0	Credits	2.5
Methodology	Lecture + Tutorial	Total Contact Periods	75
CIE	60 Marks	SEE	40 Marks

Pre requisites:

This course requires the basic knowledge of Algebra, Trigonometry in Mathematics at Secondary school level

Course Outcomes (COs):

At the end of the course, the student will have the ability to:

CO 1	Solve the problems using concepts of Logarithms and Partial fractions.
CO 2	Determine the Inverse of a square matrix using Algebra of Matrices and Determinants.
CO 3	Solve the problems using the concept of Trigonometric ratios of Allied and Compound angles
CO 4	Solve the problems using the concepts of Multiple and sub-multiple angles; and Transform sum or difference of Trigonometric ratios into products and vice versa.
CO 5	Solve the engineering problems involving Inverse Trigonometric functions and understand the Properties of Triangles.
CO 6	Solve the triangle ABC to Apply the Properties of triangles; and solve the system of linear equations that arise in various engineering problems using the concept of Matrices and Determinant

Course Content:

Unit – I Algebra:

Duration: 10 Periods (L: 08– T: 02)

Logarithms: Definition of Logarithm and its properties - Natural and Common Logarithms - Meaning of e - Exponential functions - Logarithm as a function and its graphical representation – Solve simple Problems related to Logarithms.

Partial Fractions: Rational, Proper and Improper fractions of polynomials- Reduction of Improper fractions into Proper fractions of polynomials - Resolving Rational fractions into their Partial fractions covering the types mentioned below:

- (i) $\frac{f(x)}{(x \pm a)(x \pm b)}$, $a \neq b$; (ii) $\frac{f(x)}{(x \pm a)(x \pm b)(x \pm c)}$, $a \neq b \neq c$;
 (iii) $\frac{f(x)}{(x \pm a)^2}$; (iv) $\frac{f(x)}{(x \pm a)^2(x \pm b)}$, $a \neq b$;
 (v) $\frac{f(x)}{(x \pm a)(x^2 \pm bx \pm c)}$, where a , b , and c , are constants and $(x^2 \pm bx \pm c)$ cannot be factorised.

Unit – II Matrices and Determinants: Duration: 15Periods (L: 12 – T:03)

Matrices: Definition of Matrix-order Of Matrix-Type of Matrices with examples - Algebra of matrices: sum, difference, scalar multiplication and product of Matrices - Equality of two matrices- Properties of Algebra of Matrices - Transpose of a Matrix-Symmetric and Skew-Symmetric Matrices.

Determinants: Determinant of a square Matrix of order 2×2 - Determinant of a square Matrix of order 3×3 by using Laplace's expansion -Properties of Determinants -Singular and non-singular Matrices- Minor and cofactor of an element of a square matrix - Adjoint of a square matrix- Multiplicative inverse of a square matrix.

Unit-III Trigonometry – I

Duration: 12Periods (L: 10 – T:

02)

Trigonometric Ratios of Allied Angles: Angle measurement- Relation between Degree and Radian-Notational conversions- Trigonometric Ratios-Trigonometric identities (statements only)-Signs of Trigonometric Ratios in different quadrants - Trigonometric Ratios of standard Allied angles- Related problems.

Compound Angles: Definition of Compound angles -Trigonometric Ratios of Compound angles (without proof) and identities - Related problems.

Unit-IV Trigonometry – II

Duration:13 Periods (L: 10 – T:

03)

Multiple and sub-multiple angles: Trigonometric Ratios of Multiple angles $2A$ and $3A$ - Trigonometric Ratios of Sub-multiple angle $(\frac{A}{2})$ - Related identities and problems.

Transformations: Transformation of products into sums or differences and vice versa - Trigonometric identities under the conditions $(A + B + C) = 90^0$ and $(A + B + C) = 180^0$ -Related problems only

Unit – V Trigonometry – III

Duration: 12Periods (L: 10– T:

02)

Inverse Trigonometric Functions: Basic concepts of Inverse Trigonometric functions along with their domains and ranges -Properties of inverse Trigonometric functions and identities - Related problems.

Properties of Triangles: Elements of a Triangle -Sine rule -Cosine rule - Projection rule - The law of tangents -Related problems.

Unit - VI Applications of Trigonometry and Matrices:

Duration: 13Periods (L: 10– T:03)

Solutions of Triangles: Solutions of triangles in the following cases: (i) when three sides (SSS) (ii) when two sides and an included angle (SAS) and (iii) when one side and two angles (SAA) are given..-Simple problems

Solutions of system of Simultaneous Linear Equations using Matrices and Determinants:

Solutions of system of simultaneous two linear equations in two unknown variables and threelinear equations in three unknown variables by using Cramer’s rule and Matrix Inversion Method -Elementary Row operations - Solutions of system of three simultaneous linear equations in three unknown variablesby using Gauss-Jordan Method.

Reference Books:

1. Text Book of Matrices – by Shanti Narayan and Dr. P. K. Mittal.
2. Plane Trigonometry - by S.L.Loney.
3. NCERT Mathematics Text Books of Class XI, XII (Part – I).
4. Intermediate Mathematics Text Book I A (Telugu Academy).

Suggested E-Learning references:

- 1.<https://www.khanacademy.org/>
2. <https://www.wolframalpha.com/>
3. <https://onlinecourses.nptel.ac.in/>
4. <http://tutorial.math.lamar.edu/>

Suggested Learning Outcomes:

At the end of the course, the student will have the ability to:

1.0. Apply the concepts of Logarithms and Partial fractions in engineering problems.

- 1.1 Define Logarithm.
- 1.2 Distinguish Natural Logarithms and Common Logarithms.
- 1.3 State Properties of Logarithms.
- 1.4 Explain the meaning of e and Exponential functions.
- 1.5 Define Logarithm as a function and explain its graphical representation.
- 1.6 Simplify Logarithmic expressions in engineering problems by using Properties of Logarithms.
- 1.7 Solve Logarithmic Equations by using Properties of Logarithms.
- 1.8 Define the Rational fraction of polynomials with examples.
- 1.9 Classify Rational fractions of polynomials
- 1.10 Define Proper rational fraction of polynomials with examples.
- 1.11 Define Improper rational fraction of polynomials with examples.
- 1.12 Reduce Improper rational fractions into the Proper rational fractions by using division method.
- 1.13 Resolve Rational fractions of the type: $\frac{f(x)}{(x \pm a)(x \pm b)}$ into Partial fractions, where a and b are Constants with $a \neq b$.
- 1.14 Resolve Rational fractions of the type: $\frac{f(x)}{(x \pm a)(x \pm b)(x \pm c)}$ into Partial fractions, where a , b and c are constants with $a \neq b \neq c$.
- 1.15 Resolve Rational fractions of the type: $\frac{f(x)}{(x \pm a)^2}$ into Partial fractions, where a is constant
- 1.16 Resolve Rational fractions of the type: $\frac{f(x)}{(x - a)^2(x - b)}$ into Partial fractions, where a and b are constants with $a \neq b$.
- 1.17 Resolve Rational fractions of the type: $\frac{f(x)}{(x \pm a)(x^2 \pm bx \pm c)}$ into Partial fractions, where a , b and c are constants and $(x^2 \pm bx \pm c)$ cannot be factorised further.

2.0 Determine the Inverse of a square matrix using Algebra of Matrices and Determinants.

- 2.1 Define Matrix.
- 2.2 Classify the types of Matrices with examples.
- 2.3 Define Equality of two Matrices

- 2.4 Compute the sum of two Matrices.
- 2.5 Compute the difference of two Matrices.
- 2.6 Compute the scalar multiplication of a Matrix.
- 2.7 Compute the product of two Matrices.
- 2.8 State the properties of Algebra of Matrices such as Commutative, Associative, Identity and Distributive properties with examples and counter examples.
- 2.9 Define Transpose of a Matrix and write its properties.
- 2.10 Define Symmetric and Skew-symmetric Matrices with examples.
- 2.11 Resolve a Square Matrix into a sum of Symmetric and Skew-symmetric Matrices with examples.
- 2.12 Expand the Determinant of a square of order 2×2 .
- 2.13 Expand the Determinant of a square of order 3×3 using Laplace's expansion.
- 2.14 State the Properties of Determinants.
- 2.15 Apply the Properties of Determinants to solve the problems.
- 2.16 Distinguish Singular and Non-singular Matrices.
- 2.17 Define minor and co-factor of an element of square Matrices of orders 2×2 and 3×3 with examples.
- 2.18 Compute Adjoint of a square Matrices of orders 2×2 and 3×3 .
- 2.19 Compute multiplicative inverse of non-singular square matrices of orders 2×2 and 3×3 .

3.0 Calculate Trigonometric ratios of Allied and Compound angles and solve the problems using these concepts.

- 3.1 Define Trigonometric ratios.
- 3.2 State Trigonometric identities.
- 3.3 Define Degree measure and Radian measure.
- 3.4 State the relation between Degree and Radian.
- 3.5 Convert Degree into Radian and vice-versa and related problems.
- 3.6 State signs of the Trigonometric ratios in different quadrants.
- 3.7 . Formulate Trigonometric ratios of standard Allied angles i.e. ($90^\circ \pm \theta$), ($180^\circ \pm \theta$), ($270^\circ \pm \theta$), ($360^\circ \pm \theta$) and ($-\theta$).
- 3.8 Solve the problems on Trigonometric ratios of Allied angles.
- 3.9 State the Trigonometric ratios of compound angles i.e. $\sin(A \pm B)$, $\cos(A \pm B)$, $\tan(A \pm B)$ and

Cot (A±B)).

3.10 Derive the identities i.e., $\sin(A+B) \cdot \sin(A-B) = \sin^2 A - \sin^2 B$, etc.,).

3.11 Calculate the values of $\sin 15^\circ$, $\cos 15^\circ$, $\tan 15^\circ$, $\sin 75^\circ$, $\cos 75^\circ$, $\tan 75^\circ$ etc., by using 3.9

3.12 Solve the problems by applying 3.9 and 3.10.

4.0 Solve the problems using the concepts of Multiple and sub-multiple angles; and Transform the sum or difference of Trigonometric ratios into products and vice versa.

4.1 Derive the formulae for Trigonometric ratios of multiple angles $2A$ and $3A$.

4.2 Derive the formulae for Trigonometric ratios of sub multiple angle $\frac{A}{2}$.

4.3 Derive useful identities i.e. $\sin^2 A = \left(\frac{1-\cos 2A}{2}\right)$, $\cos^2 A = \left(\frac{1+\cos 2A}{2}\right)$ etc..

4.4 Solve the problems by using 4.1, 4.2 and 4.3

4.5 Derive the formulae on transforming sum or difference of two Trigonometric ratios into a product and vice versa.

4.6 Solve the problems by applying 4.5.

4.7 Prove the Trigonometric identities under the conditions

$(A + B + C) = 90^\circ$ and $(A + B + C) = 180^\circ$.only

5.0 Solve the engineering problems involving Inverse Trigonometric functions and understand the Properties of Triangles.

5.1 Explain the concept of the inverse Trigonometric function by selecting their domains and ranges

5.2 List the Inverse Trigonometric functions along with domain and range.

5.3 State the properties of Inverse Trigonometric functions.

5.4 Derive the Inverse Trigonometric identities i.e $\sin^{-1}x + \cos^{-1}x = \frac{\pi}{2}$ etc

5.6 Derive formulae like $\tan^{-1}(x) + \tan^{-1}(y) = \tan^{-1}\left(\frac{x+y}{1-xy}\right)$ where $x \geq 0$, $y \geq 0$, $xy < 1$ etc.,

5.5 Solve the simple problems

5.6 List the elements of a triangle.

5.7 Explain the Sine rule, Cosine rule, Projection rule and the law of tangents.

5.8 Solve the problems using 5.7

6.0 Apply the Properties of triangles to solve the triangle ABC; and apply the concepts of Matrices and Determinants to solve the system of linear equations that arise in various engineering fields.

6.1 Solve the Triangle ABC, when three sides are given.

6.2 Solve the Triangle ABC, when two sides and an included angles are given.

6.3 Solve the Triangle ABC, when one side and two angles are given.

6.4 Solve the system of two linear equations in two unknown variables using Cramer's rule.

6.5 Solve the system of three linear equations in three unknown variables using Cramer's rule.

6.6 Solve the system of two linear equations in two unknown variables using Matrix Inversion Method

6.7 Solve the system of three linear equations in three unknown variables using Matrix Inversion Method.

6.8 State elementary row operations.

6.9 Solve the system of three linear equations in three unknowns by Gauss- Jordan Method.

Suggested Student Activities:

1. Student visits Library to refer Standard Books on Mathematics and collect related material.
2. Quiz
3. Group discussion
4. Group Tests
5. Formulae Tests
6. Surprise tests
7. Seminars
8. Home Assignments.
9. Mathematics- for preparing competitive exams and solve some arithmetical ability exam questions

CO / PO - MAPPING

CO	PO1	PO2	PO3	PO4	PO5	PO6	PO7	Mapped POs
CO1	3	2					3	1, 2, 7
CO2	3	2					3	1, 2, 7
CO3	3	2					3	1, 2, 7

CO4	3	2				3	1, 2, 7
CO5	3	2	2			3	1, 2, 3, 7
CO6	3	2	2			3	1, 2, 3, 7

MID SEM-I EXAM					
S.No	Unit Name	R	U	A	Remarks
1	Unit-I	1, 2	5(a) 5(b)	7(a) 7(b)	
2	Unit-II	3, 4	6(a) 6(b)	8(a) 8(b)	
Total Questions		4	4	4	
MID SEM –II EXAM					
S.No	Unit Name	R	U	A	Remarks
1	Unit-III	1, 2	5(a) 5(b)	7(a) 7(b)	
2	Unit-IV	3, 4	6(a) 6(b)	8(a) 8(b)	
Total Questions		4	4	4	

Semester End Examination

Unit No	Questions to be set for SEE				
	R		U	A	
I	4	1		9(a)	13(a)
II		2		10(a)	14(a)
III		3	5,6	9(b), 11(a), 11(b)	13(b), 15(a), 15(b)
IV				10(b), 12(a), 12(b)	14(b), 16(a), 16(b)
V			7,8		
VI					
Total Questions	8		8	8	

STATE BOARD OF TECHNICAL EDUCATION & TRAINING, TELANGANA
DIPLOMA EXAMINATIONS (C - 24)

SC-102

SEMESTER I, MID – I EXAM, MODEL PAPER
BASIC ENGINEERING MATHEMATICS

Duration: 1: 00 Hour

Max. Marks: 20

PART-A

Instructions:

1. Answer **ALL** questions.
- 2 Each question carries **ONE** mark.

04 × 01 = 04

1. Write $\log 21 + \log 5$ as a single Logarithm.
2. Define Proper fraction.
3. If $I = \begin{pmatrix} -1 & 0 \\ 0 & -1 \end{pmatrix}$ then find I^2 .
4. If $A = \begin{pmatrix} \sin \theta & \cos \theta \\ -\cos \theta & \sin \theta \end{pmatrix}$, then find the value of $|A|$.

PART-B

Instructions:

1. Answer All questions.
2. Each question carries **THREE** marks.

02 × 03 = 06

5(a) Find the value of $\log_{\frac{1}{3}} \left(\frac{1}{9} \right)$.

OR

5(b) If $\frac{3x-1}{(x-2)(x-3)} = \frac{-5}{(x-2)} + \frac{A}{(x-3)}$, then find the value of A .

6(a) If $A = \begin{pmatrix} 2 & 3 \\ 4 & 1 \end{pmatrix}$, then find AA^T .

OR

6(b) If $\begin{vmatrix} 4 & 3 & P \\ 5 & 3 & 1 \\ 2 & 1 & 6 \end{vmatrix} = 0$, then find the value of " P ".

PART C

- Instructions: 1. Answer All questions
2. Each question carries **FIVE** marks

02 × 05 = 10

7(a) Resolve $\frac{2x}{(x+1)(x^2+1)}$ into Partial fractions.

OR

7(b) Find the value of x , if $\log_4(x) + \log_4(x - 12) = 3$.

8(a) If $A = \begin{pmatrix} 1 & 2 & -1 \\ 3 & 0 & 2 \\ 4 & 5 & 0 \end{pmatrix}$ and $B = \begin{pmatrix} 1 & 0 & 0 \\ 2 & 1 & 0 \\ 0 & 1 & 3 \end{pmatrix}$, then verify that $(AB)^T = B^T A^T$.

OR

8(b) Find the inverse matrix of $A = \begin{pmatrix} 1 & 3 & 3 \\ 1 & 4 & 3 \\ 1 & 3 & 4 \end{pmatrix}$.

12(b) In any triangle ABC find the side c , if $a = 2, A = 30^\circ$ and $C = 60^\circ$.

PART C

Instructions: 1. Answer All questions

04 × 05 = 20

2. Each question carries **FIVE** marks

13(a) Resolve $\frac{2x}{x^2 + 2x + 1}$ into partial fractions.

OR

13(b) If $\tan^{-1} x + \tan^{-1} y + \tan^{-1} z = \pi$, then prove that $x + y + z = xyz$.

14(a) If $\cos x + \cos y = \frac{1}{3}$ and $\sin x + \sin y = \frac{1}{4}$, then find $\tan\left(\frac{x+y}{2}\right)$.

OR

14(b) Solve the triangle ABC, with $a = 2, b = \sqrt{2}, c = \sqrt{3} + 1$.

15(a) If $\cos^{-1} \frac{x}{a} + \cos^{-1} \frac{y}{b} = \theta$, then show that $\frac{x^2}{a^2} - \frac{2xy}{ab} \cos \theta + \frac{y^2}{b^2} = \sin^2 \theta$.

OR

15(b) Show that $\sum a \sin(B - C) = 0$.

16(a) Solve the system of simultaneous equations $x + 2y - z = -3$, $3x + y + z = 4$ and $x - y + 2z = 6$ by using Gauss-Jordan method.

OR

16(b) Using Matrix inversion method, solve the system of simultaneous equations $x + y + z = 6$,

$x - y + z = 2$ and $2x + y - z = 1$.

SC-103 : BASIC PHYSICS

Course Title:	Basic Physics	Course Code :	SC-103
Semester:	I Semester	Course Group :	Foundation
Teaching Scheme in Periods(L:T:P):	4:1:0	Credits :	2.5
Type of Course :	Lecture+ Tutorials	Total Contact Periods :	75 Periods
CIE :	60 Marks	SEE :	40 Marks

Pre requisites

This course requires the basic knowledge of Science and Mathematics

Course Outcomes

Upon completion of the course, the student shall be able to

CO1	Identify the need of dimensional analysis and error measurements of physical quantities.
CO2	Apply vector concepts viz addition, multiplication to explain resultant of vectors, work done by force, power, torque and areas of triangle and parallelogram.
CO3	Analyze the kinematic equations for projectiles and objects moving on horizontal and inclined frictional surfaces.
CO4	Make use of the fundamental properties elasticity, surface tension and viscosity of solids and fluids to solve problems in mechanics.
CO5	Develop the knowledge associated with laws of conservation of energy and Renewable Energy sources such as Solar energy and Wind energy for sustainable environment.
CO6	Utilize the principles of thermal expansion to explain thermostat and identify the significance of laws of thermodynamics.

	Basic and Discipline Specific Knowledge	Problem Analysis	Design/Development of Solutions	Engineering Tools, Experimentation and Testing	Engineering Practices for Society, Sustainability and Environment	Project Management	Lifelong Learning	Linked PO
CO	PO1	PO2	PO3	PO4	PO5	PO6	PO 7	
CO1	3	1	-	-	-	-	2	1,2,7
CO2	3	1	-	-	-	-	2	1,2,7
CO3	3	-	-	-	1	-	2	1,5,7
CO4	3	1	-	-	1	-	2	1,2,5,7
CO5	3	-	-	-	1	-	2	1,5,7
CO6	3	-	-	1	-	-	2	1,4,7

Course contents:

Unit 1 Units, Dimensions and Measurements

Duration: 12 periods (L:10 – T:2)

Physical quantity, Fundamental and derived quantities, unit-definitions- SI units - Advantages of S.I. units, Dimensions and dimensional formula - units and dimensional formulae for physical quantities - Dimensionless quantities - Principle of homogeneity – numerical problems, Applications of dimensional analysis -problems- Limitations of dimensional analysis –accuracy, precision of instruments, Errors in measurement.

Unit 2 Vectors

Duration: 13 periods (L:10 – T:3)

Scalar and Vector quantities – definition and examples, Graphical representation of a vector, Classification of vectors - numerical problems. Triangle law of vectors, Parallelogram law of vectors – statement- expression for magnitude and direction of

resultant vector –derivation- illustrations (working of sling and flying bird), Representation of a vector in terms of unit vectors \hat{i}, \hat{j} and \hat{k} – numerical problems. Scalar product of vectors- application to work done by a force and power – properties of scalar product – Numerical problems. Vector product of vectors– application to torque –areas of triangle and parallelogram - properties of vector product -numerical problems.

Unit 3 Mechanics

Duration: 13 periods (L:10 – T:3)

Equations of motion in a straight line, acceleration due to gravity, equations of motion in vertical motion, Projectile motion of a body- examples, Oblique projection-expression for path of a projectile-derivation-Maximum height, Time of ascent, Time of descent, Time of flight, Horizontal range and maximum horizontal range of a projectile in oblique projection - related numerical problems

Friction – causes-types- Normal reaction, angle of repose and coefficient of friction-laws of static friction, expression for acceleration, displacement and time taken to come to rest by a body on a rough horizontal surface –derivation-numerical problems, expressions for acceleration of a body on a rough inclined surface - advantages and disadvantages of friction, methods of minimizing friction.

Unit 4 Properties of Matter

Duration: 12 periods ((L:10 – T:2)

Elasticity and elastic bodies-definition- examples, Stress and Strain-expressions-numerical problems, types of stress and strain, Elastic limit-definition, Hooke's law, stress and strain curve,Young's modulus of a wire – derivation-numerical problems, Cohesive and Adhesive forces, Surface tension- explanation and illustrations, capillarity and angle of contact-definitions, formula for determination of surface tension of a liquid based on capillary rise method – outline and related numerical problems, effect of temperature and impurity on surface tension of a liquid, Viscosity-explanation- Newton's formula for viscous force-derivation- coefficient of viscosity-numerical problems- Poiseuille's equation for coefficient of viscosity- related numerical problems, effect of temperature on viscosity of liquids and gases, importance of viscosity in lubricants.

Unit 5 Work and Energy

Duration: 12 periods (L:10 – T:2)

Work, Power and Energy-explanation-numerical problems, Potential energy and Kinetic energy-explanation- examples, expressions for Potential energy and Kinetic energy and related numerical problems, Work-Energy theorem – statement-proof-related numerical problems, law of conservation of energy-statement-examples-proof in case of a freely

falling body - solve related numerical problems, law of conservation of energy in the case of simple pendulum, Non-renewable and Renewable energy sources-explanation-sources, Solar water heater and Wind mill.

Unit 6 Thermal Physics

Duration: 13 periods (L:10 – T:3)

Transmission of heat -Thermal expansion of solids and three coefficients of expansion of solids – applications, thermal conductivity of a solid – expression, principle of bimetallic strip, bimetallic thermostat, Boyle’s law in gases –explanation- its limitations-related numerical problems, concept of Absolute Zero, Absolute scale of temperature, Charles’ laws in gases in terms of absolute temperature – related numerical problems, Ideal gas equation-derivation- related numerical problems, gas equation in terms of density- solve related numerical problems, Isothermal and Adiabatic processes, internal energy and external work done – explanation, expression for work done by the gas –derivation-related numerical problems, 1st law of thermodynamics-explanation-list of applications, first law of thermodynamics to isothermal and adiabatic processes, 2nd law of thermodynamics –explanation- list of applications

Reference Books

1. Principles of Physics by N. Subrahmanyam and Brijlal, S. Chand & Co, New Delhi, edition, 1982
2. Engineering Physics by R.K. Gaur, S.L. Gupta, Dhanpatrai Publications, New Delhi.
3. Intermediate Physics, Telugu Academy, TS, Hyderabad.
4. Fundamentals of Physics by Halliday and Resnick.
5. Physics Part-I & II, NCERT

E-learning resources:

Hyper Physics website: <http://hyperphysics.phy-astr.gsu.edu/>

Learning Outcome:

Upon completion of this course the student will be able to

Unit 1 Units, Dimensions and Measurements

- 1.1 Define Physical quantity, Fundamental quantity, derived physical quantity and Unit.
- 1.2 List SI units of fundamental physical quantities with their symbols (Base and Supplementary quantities).

- 1.3 Outline advantages of S.I. units.
- 1.4 Define Dimensions and Dimensional formula of a physical quantity.
- 1.5 List SI units and dimensional formulae of physical quantities (Area, Volume, Density, Velocity, Acceleration, Momentum, Impulse, Force, Work, Energy, Power, Pressure, Stress, Modulus of Elasticity, Angular velocity, Torque, Frequency, Surface Tension, Coefficient of viscosity, Universal Gravitational constant, Wavelength, Planck's constant)
- 1.6 List dimensionless quantities.
- 1.7 Explain principle of homogeneity of dimensions and solve related numerical problems (finding dimensions of terms in an equation).
- 1.8 List applications of dimensional analysis and solve problems
 - (1) Correctness of physical equations
 - (i) Displacement $S = ut + \frac{1}{2}at^2$
 - (ii) Velocity of sound in elastic medium $v = \sqrt{\frac{E}{d}}$ and
 - (iii) Work done by a gas $W = P(V_2 - V_1)$
 - (2) Conversion of a unit from SI to CGS (density, force and energy).
 - (3) Construct a relation between physical quantities. (Time period of simple pendulum $T = 2\pi \sqrt{\frac{l}{g}}$)
- 1.9 List the limitations of dimensional analysis.
- 1.10 Explain error, absolute error and percentage error of a physical quantity. Solve numerical problems on percentage error.

Unit 2 Vectors

- 2.1 Define Scalar and Vector quantities with examples.
- 2.2 Represent a vector graphically and label vector characteristics.
- 2.3 Classify Vectors (Proper vector, Equal vectors, Parallel vectors, Negative vector, Unit vector, Null vector, Collinear vectors, Coplanar vectors and Position vector).
- 2.4 Explain resolution of a Vector into two orthogonal components and solve related numerical problems.
- 2.5 Explain Triangle law of vectors.
- 2.6 Explain Parallelogram law of vectors and develop expressions for magnitude and direction of resultant of two vectors and solve related numerical problems.
- 2.7 Illustrate parallelogram law of vectors (working of sling and flying bird).
- 2.8 Explain a vector in terms of unit vectors ($\hat{i}, \hat{j}, \hat{k}$) and solve related numerical problems on finding magnitude and unit vector.
- 2.9 Explain Scalar product of two vectors and solve numerical problems.

- 2.10 Construct expressions for work done ($W = \vec{F} \cdot \vec{S}$) and power ($P = \vec{F} \cdot \vec{v}$) in vector notation starting from force and solve related numerical problems.
- 2.11 Identify the properties of scalar product.
- 2.12 Explain vector product of two vectors and solve related numerical problems.
- 2.13 Construct an expression for torque in vector notation ($\vec{\tau} = \vec{r} \times \vec{F}$) starting from force and position vector and solve numerical problems.
- 2.14 Outline the expressions for areas of triangle and parallelogram in vector notation and solve numerical problems.
- 2.15 Identify the properties of vector product.

Unit 3 Mechanics

- 3.1 Outline the equations of motion in a straight line.
- 3.2 Explain acceleration due to gravity and extend the equations of motion to freely falling body and body projected vertically upward.
- 3.3 Explain projectile motion of a body with examples.
- 3.4 Develop the expression for path of a projectile in oblique projection.
- 3.5 Develop formulae for Maximum height, Time of ascent, Time of descent, Time of flight, Horizontal range and maximum horizontal range of a projectile in oblique projection and solve related numerical problems.
- 3.6 Explain friction and causes of friction.
- 3.7 Classify types of friction.
- 3.8 Explain the concept of Normal reaction, Angle of repose and Coefficient of friction.
- 3.9 Outline the laws of Static friction.
- 3.10 Develop the expression for acceleration of a body on a rough horizontal surface and solve simple numerical problems on $a = -\mu g$ and $F = \mu R$
- 3.11 Develop the expressions for displacement and time taken to come to rest by a body over a rough horizontal surface and solve simple numerical problems on $s = \frac{u^2}{2\mu g}$ and $t = \frac{u}{\mu g}$
- 3.12 Develop the expressions for acceleration of a body on a rough inclined surface (moving upward and sliding downward)
- 3.13 Outline the advantages and disadvantages of friction.
- 3.14 Identify the methods of minimizing friction.

Unit 4 Properties of Matter

- 4.1 Define Elasticity and elastic bodies with examples.
- 4.2 Explain Stress and Strain with their expressions and solve related numerical problems.
- 4.3 Explain types of stress and strain (longitudinal, shear and bulk).
- 4.4 Define Elastic limit and explain Hooke's law.
- 4.5 Explain stress and strain curve of a metallic wire.
- 4.6 Develop a formula for Young's modulus of a wire having circular cross-sectional area and solve related numerical problems.
- 4.7 Compare Cohesive and Adhesive forces.
- 4.8 Explain Surface tension and illustrate Surface tension with examples.
- 4.9 Explain capillarity and angle of contact.
- 4.10 Outline the formula for determination of surface tension of a liquid based on capillary rise method with legible diagram (no derivation $T = \frac{hrdg}{2 \cos\theta}$) and solve related numerical problems.
- 4.11 Explain the effect of temperature and impurity on surface tension of a liquid.
- 4.12 Explain Viscosity.
- 4.13 Develop Newton's formula for viscous force and explain coefficient of viscosity and solve related numerical problems.
- 4.14 Outline Poiseuille's equation for coefficient of viscosity and solve related numerical problems.
- 4.15 Explain the effect of temperature on viscosity of liquids and gases.
- 4.16 Identify the importance of viscosity in lubricants.

Unit 5 Work and Energy

- 5.1 Explain the concept of Work, Power and Energy and solve related numerical problems.
- 5.2 Explain Potential energy and Kinetic energy with examples.
- 5.3 Develop expressions for Potential energy and Kinetic energy and solve related numerical problems.
- 5.4 Develop Work-Energy theorem and solve related numerical problems.
- 5.5 Explain law of conservation of energy with examples.
- 5.6 Prove law of conservation of energy in the case of a freely falling body and solve related numerical problems.
- 5.7 Illustrate law of conservation of energy in the case of simple pendulum.
- 5.8 Explain Non-renewable and Renewable energy sources and list the sources.
- 5.9 Explain construction and working of Solar water heater and Wind mill with legible diagrams.

Unit 6 Thermal Physics

- 6.1 Explain modes of transmission of heat.
- 6.2 Explain thermal expansion of solids and develop three coefficients of expansion of solids and identify the applications.
- 6.3 Explain thermal conductivity of a solid and develop the expression for it [$Q = KA (\theta_1 - \theta_2) t$].
- 6.4 Explain principle of bimetallic strip.
- 6.5 Explain construction and working of bimetallic thermostat as an automatic temperature control device in electrical gadgets.
- 6.6 Explain Boyle's law in gases and its limitations and solve related numerical problems.
- 6.7 Explain concept of Absolute Zero using volume and pressure coefficients of a gas [$V_t = V_0(1 + \frac{t}{273})$ and $P_t = P_0(1 + \frac{t}{273})$] and develop Absolute temperature scale.
- 6.8 Explain Charles' laws in gases in terms of absolute temperature and solve related numerical problems.
- 6.9 Develop Ideal gas equation and calculate universal gas constant and solve related numerical problems.
- 6.10 Translate gas equation in terms of density and solve related numerical problems.
- 6.11 Explain Isothermal and Adiabatic processes and identify differences between them.
- 6.12 Explain the terms internal energy and external work done by a gas.
- 6.13 Develop the expression for work done by the gas [$W = P(V_2 - V_1)$] and solve related numerical problems.
- 6.14 Explain first law of thermodynamics and list applications of it and solve related numerical problems.
- 6.15 Solve first law of thermodynamics to isothermal and adiabatic processes.
- 6.16 Explain second law of thermodynamics and list applications of it.

Course Content and Blue Print of Marks for MID SEM & SEE

MID SEM-I EXAM

S.No	Unit Name	R	U	A	Remarks
1	Unit-I	1, 2	5(a) 5(b)	7(a) 7(b)	
2	Unit-II	3, 4	6(a) 6(b)	8(a) 8(b)	
Total Questions		4	4	4	

MID SEM –II EXAM

S.No	Unit Name	R	U	A	Remarks
1	Unit-III	1, 2	5(a) 5(b)	7(a) 7(b)	
2	Unit-IV	3, 4	6(a) 6(b)	8(a) 8(b)	
Total Questions		4	4	4	

Semester End Examination

Sl No	Unit No.	Questions to be set for SEE			Remarks		
		R	U	A			
1	I	4	1	9(a)	13(a)		
2	II						
3	III		2	10(a)	14(a)		
4	IV						
5	V		3	5, 6	9(b)	13(b)	
					11(a)	15(a)	
6	VI	7,8	10(b)	14(b)			
			12(a)	16(a)			
Total Questions		8	8	8			

Legend:	Remembering (R)	1 Mark
	Understanding (U)	3 Marks
	Application (A)	5 Marks

STATE BOARD OF TECHNICAL EDUCATION & TRAINING, TELANGANA

DIPLOMA EXAMINATION (C 24)

SEMESTER I

MID-I EXAM

SC 103 Basic Physics

Model Question paper

Duration: 1hour

Max.Marks: 20

PART-A

Instructions: 1. Answer **ALL** questions.

2. Each question carries **ONE** mark.

4X1 =4

1. Define fundamental physical quantity.
2. Name the dimensional formula of Power.
3. How does vector is different from scalar?
4. Define unit vector.

PART-B

Instructions: 1. Answer **ALL** questions.

2. Each question carries **THREE** marks.

2X3 =6

5(a) Outline advantages of S.I. units.

(OR)

(b) The displacement of a particle moving along x-axis with respect to time is $x=at+bt^2-ct^3$.
Find the dimensional formulae of a, b and c.

6(a) Explain triangle law of vectors.

(OR)

(b) At an airport, a horizontal wind is blowing at 15 ms^{-1} at an angle of 60° north of east.
Calculate the components of the wind velocity in the north and east directions.

PART-C

Instructions: 1. Answer **ALL** questions.

2. Each question carries **FIVE** marks.

2X5 =10

7(a) Apply dimensional analysis to convert unit of energy from SI to CGS.

(OR)

(b) Construct an expression for time period of simple pendulum using dimensional analysis starting from length of pendulum (l), mass of the bob (m) and acceleration due to gravity (g). Take proportionality constant as 2π .

8(a) Develop expressions for magnitude and direction of resultant of two vectors using parallelogram law of vectors.

(OR)

(b) Apply vector properties to find the angle between $\vec{P} = 2\hat{i} - 2\hat{j} + \hat{k}$ and $\vec{Q} = \hat{i} - 2\hat{j} + \hat{k}$

STATE BOARD OF TECHNICAL EDUCATION & TRAINING, TELANGANA

DIPLOMA EXAMINATION (C 24)

SEMESTER I

MID-II EXAM

SC 103 Basic Physics

Model Question paper

Duration: 1hour

Max.Marks: 20

PART-A

- Instructions: 1. Answer **ALL** questions.
2. Each question carries **ONE** mark.

4X1 =4

1. What is a projectile?
2. Define Normal reaction
3. Define Elastic limit.
4. Define angle of contact.

PART-B

- Instructions: 1. Answer **ALL** questions.
2. Each question carries **THREE** marks.

2X3 =6

5(a)A ball is kicked into air with a velocity of 20 ms^{-1} at an angle 30° to the Earth's surface. Find maximum height reached by the ball. (Take $g = 10 \text{ ms}^{-2}$)

(OR)

(b)Outline the laws of Static friction.

6(a)An object of weight 20 N suspended vertically from a crane on a steel cable 4 m long and 2 mm in diameter produces an elongation of 0.24 mm. Calculate the stress and strain in the cable.

(OR)

(b)Draw a neat diagram for the rise and fall of a liquid in a capillary tube showing meniscus and angle of contact.

PART-C

Instructions: 1. Answer **ALL** questions.

2. Each question carries **FIVE** marks.

2X5 =10

7(a) Develop the expression for path of a projectile in oblique projection.

(OR)

(b) Develop the expression for acceleration of a body moving up on a rough inclined surface

8(a) Develop a formula for Young's modulus of a wire having circular cross-sectional area.

(OR)

(b) Develop Newton's formula for viscous force and explain coefficient of viscosity.

STATE BOARD OF TECHNICAL EDUCATION & TRAINING, TELANGANA

DIPLOMA EXAMINATION (C 24)

SEMESTER I

SEMESTER END EXAM

SC 103 Basic Physics

Model Question paper

Duration: 2 hours

Max.Marks: 40

PART – A

- Instructions: 1. Answer **ALL** questions.
2. Each question carries **ONE** mark.

8X1=8

1. Name the dimensional formula of universal gravitational constant.
2. Define angle of repose.
3. What is kinetic energy?
4. Name one example of surface tension.
5. Define renewable energy source.
6. What is the principle of working of wind mill?
7. Define convection..
8. Define internal energy.

PART – B

- Instructions: 1. Answer **ALL** questions.
2. Each question carries **THREE** marks.

4X3=12

9(a). Explain vector product of two vectors.

(OR)

(b). A gun fires 120 bullets per minute. Find the power of the gun if the mass of each bullet is 3 g and velocity is 500 ms^{-1} .

10(a). Draw a neat diagram to show various forces acting on a body which is (a) sliding downward and (b) moving upward on a rough inclined surface.

(OR)

(b). Explain principle of bimetallic strip.

11(a). Calculate the work done by a ball of mass 2 kg when its velocity increases from 5 m/s to 10 ms^{-1} due to applied force.

(OR)

(b). The work done by a person in carrying a box of mass 20 kg through a vertical height of 5 m is 4900 J. Find the mass of the person.

12(a). The volume of a gas at 30°C is 200 cc. What is the volume of the gas if temperature of the gas is raised to 100°C at constant pressure?

(OR)

(b). Explain Boyle's law and its limitations.

PART – C

Instructions: 1. Answer **ALL** questions.

2. Each question carries **FIVE** marks.

4X5 = 20

13(a). Develop expressions for magnitude and direction of resultant of two vectors using parallelogram law of vectors.

(OR)

(b). Develop Work-Energy theorem.

14(a). Draw a schematic graph of the applied force versus resulting elongation of a metallic wire. Identify the important features in it.

(OR)

(b). Develop the relation between Pressure, Volume and Temperature of an ideal gas.

15(a). Prove law of conservation of energy in the case of a freely falling body.

(OR)

(b). Explain working of wind mill with legible diagram.

16(a). Develop the relation between Pressure, Volume and Temperature of an ideal gas.

(OR)

(b). Explain thermal conductivity of a solid and develop the expression for it.

*** ** ***

SC-104 : GENERAL ENGINEERING CHEMISTRY

Course Title	General Engineering Chemistry	Course Code	SC-104
Semester	I	Course Group	Foundation
Teaching Scheme in Periods(L:T:P)	4:1:0	Credits	2.5
Methodology	Lecture + Tutorial	Total Contact Periods	75
CIE	60 Marks	SEE	40 Marks

Prerequisite: Basic knowledge of chemistry in secondary education and appreciate the role of Chemistry and environmental science in different spheres of industries.

Course Outcome: On successful completion of the course, the students will have ability to attain below

Course Outcomes (CO):

CO1	Explain the concept of atomic structure, chemical bonding, oxidation, reduction and oxidation number and apply the knowledge in the selection of engineering materials.
CO2	Explain concept of mole, molarity, normality and colloids and utilize the knowledge in various industrial processes.
CO3	Make use of the different theories of acids and bases, concept of pH, buffer action and apply the knowledge in selection of solutions in industrial areas.
CO4	Extend the knowledge of Ecosystem, Biodiversity, Green Chemistry and Management of e-waste in maintaining the sustainable development of society.
CO5	Identify the hardness and degree of hardness of water and apply the relevant water treatment methods to solve domestic and industrial problems.
CO6	Explain the concept of electrolysis, applications of electrolysis, Faraday's Laws of Electrolysis and apply the knowledge in extraction and purification of metals used for domestic and industrial purposes.

CO-PO-Mapping

CO	PO1	PO2	PO3	PO4	PO5	PO6	PO7
CO1	3	-	-	-	-	-	1
CO2	3	1	-	-	1	-	2
CO3	3	1	-	-	-	-	2
CO4	3	-	-	-	3	-	3
CO5	3	1	-	-	3	-	-
CO6	3	1	-	-	-	-	-

COURSE CONTENTS:

UNIT-I: Fundamentals of Chemistry L10 + T3 Periods

Atomic Structure: Introduction – Atomic number – Mass number- Isotopes and Isobars -Bohr's Atomic Theory- Quantum numbers-Orbitals - Shapes of s, p and d orbitals – Aufbau principle - Hund's rule-Pauli's exclusion principle-Electronic configuration of elements

Chemical Bonding: Introduction – Electronic theory of valency - Types of chemical bonds Ionic, Covalent, Coordinate covalent and Metallic bond- properties of Ionic and Covalent compounds.

Oxidation-Reduction: Electronic concept of Oxidation, Reduction and Redox reaction.

Oxidation number-Calculations.

UNIT-II: Solutions and Colloids

L10+ T2 Periods

Introduction - Solution – Solubility - Classification of solutions based on solubility and physical state-Atomic weight-Molecular weight, Equivalent weight-Mole concept –Molarity–Normality

Numerical problems on mole, molarity and normality –Colloids- Types of colloids- Lyophilic and Lyophobic colloids- Properties of Colloids -Industrial applications of colloids

UNIT-III: Acids and Bases L10+ T2 Periods

Introduction - Theories of acids and bases and limitations - Arrhenius theory - Bronsted Lowry theory - Lewis acid base theory - Ionic product of water - pH and related numerical problems- Buffer solutions-buffer action-Applications of buffer solution-Ostwald's theory of indicators.

UNIT-IV: Environmental Science

L10+ T3 periods

Introduction-Environment –Scope and importance of environmental studies- Important terms- Concept of ecosystem - Producers, consumers and decomposers - Biodiversity, definition and threats to Biodiversity- Green Chemistry- e-waste –Management of e-waste.

UNIT-V: Water Technology

L10+ T3 periods

Introduction-Soft and hard water-Causes of hardness–Types of hardness-Disadvantages of hard water using in industries-Degree of hardness-Softening methods-Permutit process, Ion exchange process-Drinking water-Municipal treatment of water for drinking purpose–Osmosis-Reverse Osmosis-Advantages of Reverse osmosis–Desalination by Electro dialysis.

UNIT-VI: Electrochemistry

L10+ T2 Periods

Conductors, insulators, electrolytes–Types of electrolytes-Arrhenius theory of electrolytic dissociation-Electrolysis–Electrolysis of fused NaCl and aqueous NaCl-Applications of electrolysis-Faraday's laws of electrolysis-Numerical problems.

COURSE OBJECTIVES

UNIT- I: FUNDAMENTALS OF CHEMISTRY

- 1.1 Compare the mass and charge of proton, electron and neutron
- 1.2 Define and explain atomic number, mass number, isotopes and isobars
- 1.3 State the postulates of Bohr's atomic theory and its limitations
- 1.4 Explain Quantum numbers and their significances
- 1.5 Define an Orbital explain the shapes of s, p and d orbitals.
- 1.6 Outline the differences between Orbit and Orbital
- 1.7 Define electronic configuration and apply Aufbau principle, Hund's rule, and Pauli's exclusion principle in writing electronic configuration of elements up to atomic number 30
- 1.8 Explain the postulates of Electronic theory of valency
- 1.9 Define chemical bond and list the types of chemical bond
- 1.10 Define ionic bond and explain the Ionic bond formation in NaCl and MgO molecules
- 1.11 Define and explain the types of covalent bonds
- 1.12 Explain the covalent bond formation in homo atomic molecules (non-polar molecules):
 H_2, O_2, N_2
- 1.13 Explain the covalent bond formation in hetero atomic molecules (polar molecules): HF and H_2O
- 1.14 Explain the properties of ionic compounds and covalent compounds
- 1.15 Compare the properties of ionic compounds and covalent compounds
- 1.16 Define Co-ordinate covalent bond and explain the bond formation in ammonia boron trifluoride

and Hydronium ion

1.17 Define metallic bond and explain with free electron theory/ electron sea model

1.18 Define and explain the electronic concept of oxidation, reduction and redox reaction

1.19 Define oxidation number and list the rules for calculation of oxidation number

1.20 Find the oxidation number of C, N, S, P, Cr and Mn in their compounds

UNIT-II: SOLUTIONS AND COLLOIDS

2.1 Define the terms: solution, solute, solvent, aqueous solution and alcoholic solution with examples

2.2 Define solubility and classify the solutions based on solubility

2.3 Classify the solutions based on the physical state of solution, solute and solvent

2.4 Define atomic weight, molecular weight and equivalent weight

2.5 Find the molecular weight and the equivalent weights of acids, bases and salts

2.6 Explain mole concept and solve the numerical problems on mole

2.7 Define and explain molarity and normality

2.8 Find the relationship between molarity and normality

2.9 Solve numerical problems on molarity and normality of solutions

2.10 Define the terms: true solution, colloids and suspensions with examples

2.11 Classify the colloids and explain their properties

2.12 Compare the properties of Lyophilic Colloid and Lyophobic Colloid

2.13 Explain the general properties of colloids such as a) Tyndall effect b) Brownian movement and c) Coagulation

2.14 Explain in brief any five industrial applications of colloids

UNIT-III: ACIDS, BASES AND BUFFERS

3.1 Explain the postulates and limitations of Arrhenius theory of acids and bases

3.2 Explain the postulates and limitations of Bronsted - Lowry theory of acids and bases

3.3 Explain the postulates and limitations of Lewis theory of acids and bases

3.4 Define and explain the ionic product of water and solve numerical problems

3.5 Define pH and solve numerical problems on pH

3.6 Explain Ostwald's theory of indicators with phenolphthalein and methyl orange indicators as examples

3.7 Define buffer solution and explain the acidic and basic buffers with examples

3.8 Explain buffer action of Acetate buffer and Ammonium buffer

3.9 Explain general applications of buffer solutions

UNIT-IV: ENVIRONMENTAL SCIENCE

4.1 Define and explain different segments of environment: i) Atmosphere, ii) Hydrosphere, iii) Lithosphere and iv) Biosphere

4.2 Define the terms: i) Pollutant, ii) Contaminant iii) Pollution, iv) Receptor, v) Sink, vi) Particulates, vii) Threshold limit value (TLV), viii) Dissolved oxygen (DO), ix) BOD and x) COD

4.3 Define Ecosystem. Explain the biotic and abiotic components of ecosystem.

4.4 Define and explain the following biotic components with examples:

1) Producers, 2) Consumers and 3) Decomposers

4.5 Define biodiversity and explain the threats to biodiversity

4.6 Explain the methods of conservation of biodiversity

4.7 Define and explain the principles of Green chemistry

4.8 Define e-waste and explain the sources of e-Waste

4.9 Explain the effect of e-waste on environment and human beings

4.10 Explain the management of e-waste-Land filling, incineration and recycling.

UNIT V: WATER TECHNOLOGY

5.1 List the various sources of water.

5.2 Define the terms soft water and hard water

5.3 Define hardness of water and name the compounds responsible for hardness

5.4 Define and explain the types of hardness

5.5 Identify the disadvantages of using hard water in industries: i) Boilers ii) Laundry, iii) Textile industry, iv) Paper industry, v) Sugar Industry and vi) Pharmaceutical industry

5.6 Define degree of hardness and explain different units of hardness - ppm and mg/L solve numerical problems on degree of hardness

5.7 Utilize and explain a) Permutit process and b) Ion-Exchange process in softening of hard water:

5.8 Define desalination of water

- 5.9 Define Osmosis and Reverse Osmosis (RO)
- 5.10 Explain the process of conversion of sea water into drinking water by reverse osmosis
- 5.11 List the applications and advantages of RO.
- 5.12 Explain the desalination of sea water by Electro dialysis.
- 5.13 List the essential qualities of drinking water.
- 5.14 Explain the Municipal treatment of water for drinking purpose with flow chart-
- a) Sedimentation b) Coagulation c) Filtration, d) Sterilization by Aeration and Chlorination

UNIT VI: ELECTROCHEMISTRY

- 6.1 Define the terms, conductor, insulator, electrolyte and non-electrolyte
- 6.2 Classify the electrolytes - strong and weak electrolytes with examples.
- 6.3 Compare and contrast the metallic conductors and electrolytic conductors.
- 6.4 Explain the Arrhenius theory of electrolytic dissociation.
- 6.5 Define electrolysis.
- 6.6 State and explain Faraday's laws of electrolysis
- 6.7 Define chemical equivalent and electrochemical equivalent and their relation
- 6.8 Numerical problems based on Faraday's I-law and II- law
- 6.9 Construct the suitable electrolytic cell to explain the electrolysis of fused NaCl and aqueous NaCl (Nelson Cell).
- 6.10 Apply the principle of electrolysis in Electrolytic refining of copper metal and Electroplating.

Time:1Hour

Max.Marks:20

PART-A

Instructions: Answer all questions. Each question carries one mark 4 x 1 =

4 Marks

1. State Hund's rule.
2. What is the electronic configuration of Cr.
3. Define mole.
4. What are colloids?

PART-B

Instructions: Answer the following questions.

2 x 3 = 6 Marks

Each question carries three marks

5. a) Outline the shapes of s and d orbitals.

(OR)

5. b) Explain the covalent bond formation in Nitrogen molecule by Lewis dot method.

6. a) Classify solutions based on their physical state.

(OR)

6. b) Compare any three properties of lyophilic and lyophobic colloids.

PART - C

Instructions: Answer the following questions.

2 x 5 = 10 Marks

Each question carries five marks

7. a) Identify and explain the nature of bonding in the following molecule 1. MgO, 2. HCl

(OR)

- b) Find the oxidation number of 'S' in H_2SO_4 , 'Mn' in KMnO_4 and 'Cr' in $\text{K}_2\text{Cr}_2\text{O}_7$

8. a) Find the weight of H_2SO_4 required to prepare 400 ml of 0.5M solution.

(OR)

- b) Find the normality of 500 ml solution containing 0.53 grams of Na_2CO_3 .

MIDSEM -II
SC-104-GENERAL ENGINEERING CHEMISTRY

Time: 1 Hour

Max. Marks: 20

PART-A

Instructions: Answer all questions. Each question carries one mark 4 x 1 =

4 Marks

1. What is conjugate acid base pair?
2. Define ionic product of water.
3. Define an ecosystem.
4. What is threshold limit value?

PART-B

Instructions: Answer the following questions.

2 x 3 = 6 Marks

Each question carries three marks

5. a) .Outline the limitations of Arrhenius theory of acids and bases?

(OR)

- b) Explain neutralization according to Lewis theory of acids and bases with an example.

6. a) Explain the terms producers, consumers and decomposers with example.

(OR)

- b) Explain the effect of e-waste on environment.

PART - C

Instructions: Answer the following questions.

2 x 5 = 10 Marks

Each question carries five marks

7. a) Define pH. Find the pH of 0.5M NaOH solution.

(OR)

8. b) What are buffer solutions? Explain any four applications of buffer solutions.

9. a) What is Biodiversity? Explain the methods of Conservation of Biodiversity.

(OR)

- b) What is Green chemistry? Explain any four principles of Green Chemistry.

SEMESTER END EXAMINATION
SC-104-GENERAL ENGINEERING CHEMISTRY

Time: 2 Hours

Max. Marks: 40

PART-A

Instructions: Answer all questions. Each question carries one mark. 8 X 1 = 8 marks

1. Define atomic mass number.
2. What is biodiversity?
3. Define degree of hardness of water.
4. What are buffer solutions?
5. Define soft water and hard water.
6. Name the salts responsible for temporary hardness of water.
7. Define the terms conductor and insulator.
8. What is an electrolyte?

PART- B

Instructions: Answer the following questions.

4x3=12 Marks

Each question carries three marks

9. a) State and explain Hund's rule.

(OR)

- b) Interpret any six essential qualities of drinking water.

10. a) Explain the terms producers, consumers and decomposers with examples.

(OR)

- b) Explain strong and weak electrolytes? Give examples.

11. a) Define reverse osmosis and predict its advantages.

(OR)

- b) Compare temporary and permanent hardness of water.

12. a) Identify the differences between metallic and electrolytic conductors.

(OR)

b) Explain Faraday's Laws of electrolysis.

PART- C

Instructions: Answer the following questions.

4 x 5 = 20 Marks

Each question carries five marks.

13. a) Find the Molarity and Normality of the two liters of solution containing 10.6 grams of Na_2CO_3 .

(OR)

b) Find the temporary and permanent hardness of water containing the following salts per liter

i. $\text{Ca}(\text{HCO}_3)_2 = 32.4 \text{ mg}$ ii. $\text{Mg}(\text{HCO}_3)_2 = 29.2 \text{ mg}$ iii. $\text{CaSO}_4 = 13.6 \text{ mg}$ iv. $\text{MgCl}_2 = 19 \text{ mg}$

14. a) Explain Lewis theory of acids and bases.

(OR)

b) Explain the process of electrolysis of fused NaCl .

15. a) Explain the Permutit process of softening of hard water with a neat labeled diagram.

(OR)

b) Identify and explain the disadvantages of using hard water in the following industries?

i). Boilers ii) Laundry iii) Paper industry iv) Textile industry v) Pharmaceuticals

16. a). Explain the process of electrolytic refining of copper.

(OR)

b) Find the weight of Al deposited on the cathode if 0.5 amperes of electric current is passed through AlCl_3 solution for 1 hour.

EC-105 : BASIC ELECTRONICS

Course Title:	Basic Electronics	Course Code	EC-105
Semester	I Semester	Course Group	Core
Teaching Scheme in Periods (L:T:P)	4:1:0	Credits	2.5
Methodology	Lecture+Tutorials	Total Contact Periods	75
CIE	60 Marks	SEE	40 Marks

Pre-requisites:

Basic knowledge of physics and mathematics, also AC and DC voltages and currents.

Course Outcomes: Upon completion of the course, the student shall be able to

CO1	Apply the selection of resistors in electronic circuits.
CO2	Apply the selection of capacitors in electronic circuits.
CO3	Apply the selection of inductors and transformers in electronic circuits
CO4	Use of electrical components in day-to-day life
CO5	Solve basic electrical circuits.
CO6	Comprehend AC fundamentals

Course Content and Blue Print of Marks for SEE

Unit No	Unit Name	Periods	Questions to be set for SEE			
			R	U	A	
I	Resistors	15	Q4	Q1	Q9(a)	Q13(a)
II	Capacitors	10				
III	Inductors and Transformers	10				
IV	Switches, Fuses and Relays	15		Q2	Q10(a)	Q14(a)
V	KVL, KCL, Star Delta Transformation	15				
VI	AC Fundamentals	10		Q3	Q5, Q6	Q9(b), Q11(a), Q11(b)
	Total	75		Q7, Q8	Q10(b), Q12(a), Q12(b)	Q14(b), Q16(a), Q16(b)
			8	8	8	8

Course Contents

Unit-1 Resistors

Duration: 15 Periods (L:13– T:2)

Types of resistors- specifications of a resistor, importance of specifications - necessity of preferred values in resistor- features and applications of the Metal film Resistors-Resistance Value by using Colour coding of Carbon Film Resistors. (4 band and 5 band)- common faults in resistors.

Applications of Wire wound Resistor- two types of Variable Resistors-Distinguish between Preset and Potentiometer- European and US standard symbols of Potentiometers and Presets- Compare the features of carbon and wire wound potentiometers-specifications for the carbon and wire wound potentiometers-applications. of carbon and wire wound potentiometers- terms: specific resistance and conductivity-Deduce the relation $R = \rho l/a$ - Solve simple problems using the above formula- simple problems on Series and parallel connections of Resistances-effects of temperature on resistance - temperature co- efficient of resistance- formula $R_t = R_o (1 + \alpha \Delta t)$ to find resistance at any given temperature - Simple problems using the above formula-series and parallel connections of Resistances - expressions for equivalent resistance for series and parallel connections- simple problems on series and parallel circuits- division of current in parallel circuits- simple problems on the above.

Unit-2 Capacitors

Duration: 10 Periods (L:8– T:2)

Different types of capacitors-specifications of a capacitor and state their importance. different markings on the a) Electrolytic capacitors b) Ceramic and Plastic capacitors (Value, Polarization, Voltage, Tolerance, temperature rating)-working voltage of a capacitor-Reading of capacitor value and tolerance by 1. Colour code. 2.Value printed.

Factors affecting the capacitance of a capacitor-properties, range of values and applications of paper, glass, polyester, ceramic and Electrolytic capacitors-importance of polarity in Electrolytic capacitors. -use of capacitors for coupling AC signal and blocking DC-self-healing in metalized capacitors-different types of variable capacitors and mention their applications-use of ganged capacitor in AM radio for tuning-use of trimmer capacitors-losses in capacitors-common faults in capacitors.

Unit-3 Inductors and Transformers

Duration: 10Periods (L:8– T:2)

Properties of inductors, Compare R, L and C, classify inductors, symbols of different inductors, mutual inductance, Coefficient of coupling, Self-inductance and mutual inductance in terms of emf, series and parallel connection of inductors, simple problems on inductors, specifications of inductors, applications of inductors, need of transformer, working principle of transformer, transformation ratio K, applications of transformer.

Unit-4 Switches, fuses and Relays**Duration: 15 Periods (L:13– T:2)**

Working of a switch, switches according to poles and throws (SPST, SPDT, DPST, DPDT, Multi-pole multi-throw), Classify switches according to mechanism (rotary, toggle, sliding) and size, Applications of various switches, I.S.I symbols of various switches, need of fuse in electronic equipment, types of fuses, metals used for fuses, significance of fuse ratings, need for connectors in electronic circuits, types of connectors, use of MCB. Electromagnetic relay, working of a relay, different relays based on principle of operation, polarization and, applications of relays,

Unit-5 KVL, KCL, Star delta transformation**Duration: 15 Periods (L:12– T:3)**

Simple DC circuits problems using KVL and KCL, ideal voltage source, ideal current source, practical voltage and current sources, source transformation techniques, problems related to source transformation, star and delta networks, formulae for star to delta conversion, formulae for delta to star conversion, problems related to star delta networks

Unit-6 AC fundamentals**Duration: 10 Periods (L:8– T:2)**

DC and A.C voltage, sine wave and concept of a cycle, Time period , Frequency and Amplitude of a sine wave , formula for the instantaneous value in terms of maximum value, frequency and time, different forms of emf equation, simple problems to calculate Amplitude ,frequency and Time Period, average value, R.M.S. value, form factor and peak factor for sine wave, phase and phase difference, concept of Leading , lagging and in phase with the help of waveforms, phasor diagrams for sine waves, vector diagrams for sine waves, problems on vector addition of alternating quantities, problems on vector subtraction of alternating quantities.

Reference Books

1. Electrical Technology vol.1 :B L Teraja
2. Electrical Technology vol.2 : B L Teraja

Suggested E-learning references

- 1) <https://www.pearsonhighered.com/assets/samplechapter/0/1/3/2/0132859610.pdf>

- 2) www.electronics-tutorials.ws
- 3) www.nptel.ac.in

Suggested Learning Outcomes

Upon completion of the course, the student shall be able to

CO1: Apply the selection of resistors in electronic circuits

- 1.1 Classify resistors.
- 1.2 List the specifications of a resistor, and state their importance.
- 1.3 Explain the necessity of preferred values in resistor.
- 1.4 List the features and applications of the Metal film Resistors.
- 1.5 Identify Resistance Value by using Colour coding of Carbon Film Resistors.(4 band and 5 band).
- 1.6 List the common faults in resistors.
- 1.7 List applications of Wire wound Resistor.
- 1.8 List the types of Variable resistors.
- 1.9 Distinguish between Preset and Potentiometer.
- 1.10 Draw the European and US standard symbols of Potentiometers and Presets.
- 1.11 Compare the features of carbon and wire wound potentiometers.
- 1.12 Give standard specifications for the carbon and wire wound potentiometers.
- 1.13 List applications. of carbon and wire wound potentiometers.
- 1.14 Define the terms specific resistance and conductivity.
- 1.15 Deduce the relation $R = (\rho l) / a$
- 1.16 Solve simple problems using the above formula.
- 1.17 Solve simple problems on Series and parallel connections of Resistances-
- 1.18 Explain the effects of temperature on resistance
- 1.19 Define temperature co- efficient of resistance.
- 1.20 Derive the formula $R_t = R_o (1 + \alpha \Delta t)$ to find resistance at any given temperature
- 1.21 Solve Simple problems using the above formula.
- 1.22 Explain series and parallel connections of Resistances
- 1.23 Derive the expressions for equivalent resistance for series and parallel connections.
- 1.24 Solve simple problems on series and parallel circuits
- 1.25 Explain the division of current in parallel circuits

1.26 Solve simple problems on the above.

CO2: Apply the selection of capacitors in electronic circuits.

- 2.1 Classify capacitors.
- 2.2 List the specifications of a capacitor and state their importance.
- 2.3 Explain different markings on the a) Electrolytic capacitors b) Ceramic and Plastic capacitors (Value, Polarization, Voltage, Tolerance, temperature rating).
- 2.4 Define working voltage of a capacitor.
- 2.5 Reading of capacitor value and tolerance by 1. Colour code. 2.Value printed.
- 2.6 State the factors affecting the capacitance of a capacitor.
- 2.7 Mention the properties, range of values and applications of paper, glass, polyester, ceramic and Electrolytic capacitors.
- 2.8 Explain the importance of polarity in Electrolytic capacitors.
- 2.9 Explain the use of capacitors for coupling AC signal and blocking DC.
- 2.10 Explain self-healing in metalized capacitors.
- 2.11 List different types of variable capacitors and mention their applications.
- 2.12 Explain the use of ganged capacitor in AM radio for tuning.
- 2.13 Explain the use of trimmer capacitors.
- 2.14 Mention the losses in capacitors.
- 2.15 List common faults in capacitors.

CO3: Apply the selection of inductors and transformers in electronic circuits.

- 3.1 Classify inductors Draw the symbol of different types of inductors.
- 3.2 List the specifications of inductors.
- 3.3 List and explain the important parameters of Air cored inductors.
- 3.4 Explain the terms Stray inductance and stray capacitance.
- 3.5 List various core materials used in the construction of inductors.
- 3.6 List the applications of A.F. and R.F chokes.
- 3.7 List the common faults in inductors.
- 3.8 Define Transformer
- 3.9 Explain the principle of Transformer
- 3.10 Mention the use of transformer in electrical and electronic Engineering applications
- 3.11 Explain the use of Ferrites in the construction of high frequency inductors.
- 3.12 Define Self Inductance
- 3.13 Define Mutual Inductance, coefficient of coupling
- 3.14 Deduce the relation between Mutual Inductance, coefficient of coupling

CO4: Use of electrical components in day-to-day life

- 4.1 Classify switches according to poles and throws (SPST, SPDT, DPST, DPDT, Multi-pole multi-throw).
- 4.2 Classify switches according to mechanism (rotary, toggle, sliding) and size
- 4.3 List the applications of various switches
- 4.4 Draw the I.S.I symbols of various switches.
- 4.5 Explain the need of fuse in electronic equipment.
- 4.6 Mention different types of fuses.
- 4.7 List metals used for fuses.
- 4.8 Mention significance of fuse ratings.
- 4.9 State the need for connectors in electronic circuits
- 4.10 List different types of connectors.
- 4.11 Mention the use of MCB
- 4.12 Define electromagnetic relay
- 4.13 List the different types of relays based on principle of operation, polarization
- 4.14 List the applications of relays in electronic circuits.
- 4.15 Explain the working of relay with a neat figure.

CO5: Solve basic electrical circuits.

- 5.1 Solve simple DC circuits problems using KVL and KCL
- 5.2 Define ideal voltage source
- 5.3 Define ideal current source
- 5.4 Explain practical voltage and current sources
- 5.5 Explain source transformation techniques
- 5.6 Solve simple problems related to source transformation
- 5.7 Draw star and delta networks
- 5.8 Write the transformation formulae for star to delta conversion
- 5.9 Write the transformation formulae for delta to star conversion
- 5.10 Solve problems related to star delta networks

CO6: Comprehend AC fundamentals.

- 6.1 Define the terms DC and A.C voltage
- 6.2 Draw the sine wave and explain the concept of a cycle
- 6.3 Define Time period, Frequency and Amplitude of a sine wave
- 6.4 Give the formula for the instantaneous value in terms of maximum value, frequency and time.
- 6.5 Write different forms of emf equation.
- 6.6 Solve simple problems to calculate Amplitude, frequency and Time Period
- 6.7 Define the average value, R.M.S. value, form factor and peak factor for sine wave.
- 6.8 Explain the terms phase and phase difference.
- 6.9 Explain the concept of Leading, lagging and in phase with the help of waveforms.
- 6.10 Draw phasor diagrams for sine waves.
- 6.11 Draw vector diagrams for sine waves.
- 6.12 Solve problems on vector addition of alternating quantities.
- 6.13 Solve problems on vector subtraction of alternating quantities.

Suggested Student Activities

- 1. Visit the Institute's Library / internet center and list the books/journals/ e-books and any other resources available on the topics suggested by the teacher.
- 2. Prepare a chart showing the symbols and names of various devices.
- 3. Prepare a PPT identifying the need for these semiconductor devices and their use in electronic industry.

CO-PO Mapping Matrix

	Basic and Discipline Specific Knowledge	Problem Analysis	Design/Development of Solutions	Engineering Tools, Experimentation and Testing	Engineering Practices for Society, Sustainability and Environment	Project Management	Lifelong Learning	Linked PO
CO	PO1	PO2	PO3	PO4	PO5	PO6	PO 7	
CO1	3	1				1		1,2,6
CO2	3	1				1		1,2,6,
CO3	3	1						1,2
CO4	3	1				2	1	1,2,6,7
CO5	3	3					1	1,2,7
CO6	3	3					1	1,2,7

QUESTION PAPER PATTERN FOR MID SEMESTER EXAMS

Sl.No	Description	Level	No of Questions	Marks for each question	Choice	Total Marks
01	Part-A	Remembering(R)	4	1	Nil	4 Marks
02	Part-B	Understanding(U)	4	3	2	6 Marks
03	Part-C	Application(A)	4	5	2	10 Marks
Total Marks						20 Marks

MID SEM-I EXAM

S.No	Unit No	R	U	A	Remarks
1	Unit-I	1,2	5(a)	7(a)	
			5(b)	7(b)	
2	Unit-II	3,4	6(a)	8(a)	
			6(b)	8(b)	
Total Questions		4	4	4	

MID SEM-II EXAM

S.No	Unit No	R	U	A	Remarks
1	Unit-III	1,2	5(a)	7(a)	
			5(b)	7(b)	
2	Unit-IV	3,4	6(a)	8(a)	
			6(b)	8(b)	

Total Questions		4	4	4	
-----------------	--	---	---	---	--

The length of answer for each question framed in respect of Part-A, B&C shall not exceed ¼ of a page,1 page and 2 pages respectively

QUESTION PAPER PATTERN FOR SEMESTER END EXAM

Sl.No	Description	Level	No of Questions	Marks for each question	Choice	Total Marks
01	Part-A	Remembering(R)	8	1	Nil	8 Marks
02	Part-B	Understanding(U)	8	3	4	12 Marks
03	Part-C	Application(A)	8	5	4	20 Marks
Total Marks						40 Marks

Unit No	Questions to be set for SEE				
	R		U	A	
I	Q4	Q1		Q9(a)	Q13(a)
II				Q10(a)	Q14(a)
III		Q2		Q9(b), Q11(a), Q11(b)	Q13(b), Q15(a), Q15(b)
IV					
V		Q7,Q8	Q14(b), Q16(a), Q16(b)		
VI		8		8	8
Total Questions	8		8	8	

State Board of Technical Education and Training, Telangana

Model Question paper

DECE I semester

Mid Semester-I Examination

Course Code: EC-105

Duration: 1 hour

Course Name: Basic Electronics

Max.Marks: 20 Marks

PART-A

Answer all questions, Each Question carries ONE-mark

4x1=4 Marks

1. Define specific resistance.
2. List any 2 applications of Wire wound Resistor.
3. Define working voltage of a capacitor.
4. List 2 common faults in capacitors.

PART-B

Answer TWO questions. Each question carries THREE marks

2x3 = 6 Marks

- 5(a). Deduce the relation $R = \frac{l}{a}$.

(OR)

- 5(b). Distinguish between Preset and Potentiometer.

- 6(a). Mention the properties, range of values and applications of Electrolytic capacitors.

(OR)

- 6(b). State the factors affecting the capacitance of a capacitor.

PART-C

Answer TWO questions. Each question carries FIVE marks

2x5= 10

Marks

- 7(a). Derive the expression for equivalent resistance for parallel connection of resistors.

(OR)

- 7(b). Derive the formula $R_t = R_o (1 + \alpha_o t)$ to find resistance at any given temperature

- 8(a). Explain the use of capacitors for coupling AC signal and blocking DC.

(OR)

- 8(b). Explain different markings on the Ceramic and Plastic capacitors.

State Board of Technical Education and Training, Telangana
Model Question paper
DECE I semester
Mid Semester-II Examination

Course Code: EC-105

Duration:1 hour

Course Name: Basic Electronics

Max.Marks:20 Marks

PART-A

Answer all questions, Each Question carries ONE-mark

4x1=4 Marks

1. Define Mutual Inductance.
2. Define Transformer.
3. List 2 metals used for fuses.
4. Define electromagnetic relay

PART-B

Answer TWO questions. Each question carries THREEmarks

2x3 = 6 Marks

- 5(a). List the applications of A.F. and R.F chokes.

(OR)

- 5(b). Mention the use of transformer in electrical and electronic Engineering applications.

- 6(a). Mention the use of MCB

(OR)

- 6(b). State the need for connectors in electronic circuits

PART-C

Answer TWO questions. Each question carries FIVE marks

2x5= 10

Marks

- 7(a). Explain the principle of Transformer

(OR)

- 7(b). Derive the relation between Mutual Inductance, coefficient of coupling.

- 8(a). Explain the working of relay with a neat figure.

(OR)

- 8(b). Explain the need of fuse in electronic equipment.

State Board of Technical Education and Training, Telangana
Model Question paper
DECE IV semester
I Semester End Examination

Course Code: EC-105

Duration: 2 hours

Course Name: Basic Electronics

Max. Marks: 40 Marks

PART-A

Answer all questions. Each Question carries one-mark

8x1 = 8 Marks

1. Define conductivity.
2. Define Self Inductance.
3. Define the average value.
4. List 2 common faults in capacitors.
5. Define ideal voltage source.
6. Draw a practical current source.
7. Define Frequency of a sine wave.
8. Write one form of emf equation.

PART-B

Answer FOUR questions. Each question carries three marks.

4 x 3 = 12 Marks

9(a). Compare the features of carbon and wire wound potentiometers.

(OR)

9(b). Write the transformation formulae for star to delta conversion

10(a). List the different types of relays based on principle of operation.

(OR)

10(b). Explain the terms phase and phase difference.

11(a). Calculate the voltage across the 10-ohm resistor.

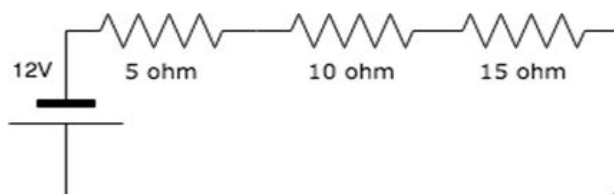

(OR)

11(b). Draw star and delta networks

12(a). Explain the terms phase and phase difference.

(OR)

12(b). Draw the sine wave and explain the concept of a cycle

PART-C

Answer FOUR questions. Each Question carries FIVE marks

4 x 5 = 20 Marks

13(a) Explain the use of ganged capacitor in AM radio for tuning.

(OR)

13(b) Explain source transformation techniques.

14(a) List and explain the important parameters of Air cored inductors.

(OR)

14(b) Two currents i_1 and i_2 are given by the expressions

$i_1 = 10 \sin (314t + \pi/4)$ amperes and $i_2 = 8 \sin (313 t - \pi/3)$ amperes. Find $i_1 + i_2$.

15(a) Find the equivalent delta circuit.

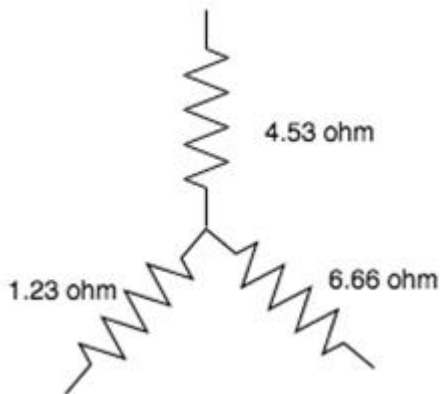

(OR)

15(b) Calculate $i = ?$

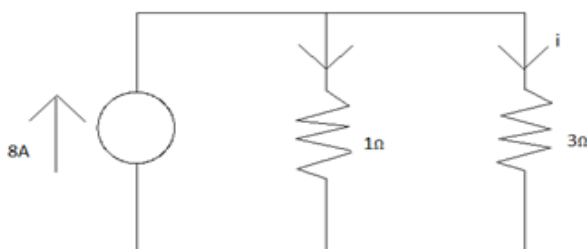

16(a) Three sinusoidally alternating currents of rms values 5, 7.5, and 10 A are having same frequency of 50 Hz, with phase angles of 30° , 60° and 45° . (i) Find their average values, (ii) Write equations for their instantaneous values

(OR)

16(b) Explain the concept of Leading, lagging and in phase with the help of waveforms.

EC-106 : SEMICONDUCTOR DEVICES

Course Title:	Semiconductor Devices	Course Code	EC-106
Semester	I Semester	Course Group	Core
Teaching Scheme in Periods (L:T:P)	4:1:0	Credits	2.5
Methodology	Lecture+Tutorials	Total Contact Periods	75
CIE	60 Marks	SEE	40 Marks

Pre requisites

Basic knowledge of Physics and Mathematics, also concepts of AC and DC voltages and currents.

Course Outcomes

Upon completion of the course, the student shall be able to

CO1	Comprehend semiconductor theory and interpret the working of extrinsic semiconductor
CO2	Use of semiconductor diode and Zener diode
CO3	Analyze the different configurations of transistor and compare them
CO4	Identify the need of regulated power supply in various applications and function of different components used in it
CO5	Outline the different types of FETs and compare BJT with FET
CO6	Classify MOSFETs and compare them

Course Content and Blue Print of Marks for SEE

Unit No	Unit Name	Periods	Questions to be set for SEE			
			R	U	A	
I	Semiconductor theory	10	Q4	Q1	Q9(a)	Q13(a)
II	Semiconductor diode and Zener diode	15				
III	Bipolar Junction Transistor	15		Q2	Q10(a)	Q14(a)
IV	DC Power supply and components. Junction	10				
V	Field Effect Transistor	10	Q3	Q5,Q6	Q9(b),Q11(a), Q11(b)	Q13(b),Q15(a), Q15(b)
VI	Metal Oxide semiconductor FET	15		Q7,Q8	Q10(b),Q12(a), Q12(b)	Q14(b),Q16(a), Q16(b)
	Total	75		8	8	8

Course Content

UNIT - 1: Semiconductor theory Duration: 10 Periods (L: 8 – T:2)

Electrical properties of semiconductors-energy level diagrams for conductors, semiconductors and insulators-need for doping-formation of N-type semiconductor formation of P-type semiconductor-energy band diagrams for the N-Type and P-Type Semiconductors.Distinguish between intrinsic and extrinsic semiconductor-majority and minority carriers-Fermi level-acceptor impurities-donor impurities-differences in properties of germanium and silicon.

UNIT - 2:Semiconductor diode and Zener diode Duration: 15 Periods(L:13 – T:2)

Working of PN diode under no bias condition-PN diode under forward bias condition and under reverse bias condition-forward bias characteristics-reverse bias characteristics-specifications of semiconductor diode-working principle of Zener diode-difference in the construction of Zener from semiconductor diode-characteristics of Zener diode- Compare zener and semiconductor diode-avalanche breakdown-Zener breakdown.

UNIT - 3: Bipolar Junction Transistor Duration: 15Periods(L:13 – T:2)

Define transistor-different types of transistors-symbols of transistors-terminals of a transistor, working of NPN transistor and PNP transistor-different transistor configurations-circuit diagram of CB,CE and CC configurations-cutoff, saturation and active regions-alpha, beta and gamma factors, relation between alpha and beta, relation between alpha and gamma, relation between beta and gamma-expression for collector current in CE configuration, input and output characteristics of CB configuration-CE configuration-CC configuration- Compare the different configurations of transistors.

UNIT – 4: DC Power supply and components Duration: 10 Periods (L:9– T:1)

Necessity of DC power supply in electronic circuits-block diagram of a regulated power supply-function of each block-types of rectifiers-working of half wave rectifier-the input and output waveforms of HW and FWR-working of full wave rectifier-working of bridge rectifier-input and output waveforms of BR-need for a filter-different types of filter circuits-ripple factor, peak inverse value and efficiency-values for each rectifier - need for online and offline UPS-need for SMPS.

UNIT - 5: Field Effect Transistor

Duration: 10Periods(L:8– T:2)

Different types of FETs-construction of JFET-symbols of FETs-terminals of FET-working of FET-drain characteristics of FET-mutual characteristics of FET-parameters of FET-relation between parameters -specifications of JFET-applications of FET-Distinguish between BJT and FET-advantages of FET over BJT-disadvantages of FET over BJT.

UNIT - 6: Metal Oxide Semiconductor FET Duration: 15 Periods(L:13 – T:2)

Define MOSFET-different types of MOSFET-symbols of MOSFETs.-terminals of MOSFET, working principle of the MOSFET -construction of the MOSFET -differences between FETs and MOSFETs.-advantages of MOSFETs-construction of depletion MOSFET-working of the MOSFET -construction and working of enhancement MOSFET- -characteristics of depletion MOSFET-characteristics of enhancement MOSFET-Distinguish between enhancement and depletion MOSFET.

Reference Books

1. Principles of Electronics : V.K.Mehta
2. Electronic devices & circuits: Millman&Halkias
3. Electronic devices & circuits: JB Gupta

1. P
rinciple

Suggested E-learning references

electrical4u.com/

- 1) www.electronics-tutorials.ws
- 2) www.nptel.ac.in

1)
http://el

Suggested Learning Outcomes

Upon

completion of the course, the student shall be able to

CO1: Comprehend semiconductor theory and interpret the working of extrinsic semiconductor

- 1.1 State the electrical properties of semiconductors.
- 1.2 Draw energy level diagrams for conductors, semiconductors and insulators.
- 1.3 State the need for doping.
- 1.4 Explain the formation of N-type semiconductor.
- 1.5 Explain the formation of P-type semiconductor.
- 1.6 Draw the energy band diagrams for N-type and P-type semiconductors.
- 1.7 Distinguish between intrinsic and extrinsic semiconductor.
- 1.8 Define majority and minority carriers.
- 1.9 Define Fermi level.
- 1.10 Define acceptor impurities.
- 1.11 Define donor impurities.
- 1.12 Identify the differences in properties of germanium and silicon.

CO2: Use of semiconductor diode and Zener diode.

- 2.1 Explain the working of PN diode under no bias condition.
- 2.2 Explain the working of PN diode under forward bias condition.
- 2.3 Explain the working of PN diode under reverse bias condition.
- 2.4 Explain the forward bias characteristics.
- 2.5 Explain the reverse bias characteristics.
- 2.6 List the specifications of semiconductor diode.
- 2.7 Explain the working principle of Zener diode.
- 2.8 Identify the difference in the construction of Zener from semiconductor diode.
- 2.9 Explain the characteristics of Zener.
- 2.10 Compare Zener and semiconductor diode.
- 2.11 Explain avalanche breakdown.
- 2.12 Explain Zener breakdown.

CO3: Analyze the different configurations of transistor and compare them

- 3.1 Define transistor.
- 3.2 List the different types of transistors.
- 3.3 Draw the symbols of transistors.
- 3.4 Identify the terminals of a transistor.
- 3.5 Explain the working of NPN transistor.
- 3.6 Explain the working of PNP transistor.
- 3.7 What are the different transistor configurations?
- 3.8 Draw the circuit diagram of CB,CE and CC configurations.
- 3.9 Define cutoff saturation and active regions.
- 3.10 Define alpha, beta and gamma factors.
- 3.11 Derive the relation between alpha and beta.
- 3.12 Derive the relation between alpha and gamma.
- 3.13 Derive the relation between beta and gamma.
- 3.14 Derive the expression for collector current in CE configuration.
- 3.15 Draw the input and output characteristics of CB configuration.
- 3.16 Draw the input and output characteristics of CE configuration.
- 3.17 Draw the input and output characteristics of CC configuration.
- 3.18 Compare the different configurations of transistors.

CO4: Identify the need of regulated power supply in various applications and function of different components used in it

- 4.1 Explain the necessity of DC power supply in electronic circuits.
- 4.2 Draw the block diagram of a regulated power supply.
- 4.3 Explain the function of each block.
- 4.4 List the types of rectifiers.
- 4.5 Explain the working of half wave rectifier.
- 4.6 Draw the input and output waveforms of above.
- 4.7 Explain the working of full wave rectifier.
- 4.8 Draw the input and output waveforms of above.
- 4.9 Explain the working of bridge wave rectifier.
- 4.10 Draw the input and output waveforms of above.
- 4.11 Identify the need for a filter.
- 4.12 Classify the different types of filter circuits.
- 4.13 Define ripple factor, peak inverse value and efficiency
- 4.14 What are these values for each rectifier?
- 4.15 Interpret the need for online and offline UPS.
- 4.16 Identify the need for SMPS.

CO5: Outline the different types of FETs and compare BJT with FET.

- 5.1 Classify the different types of FETs.
- 5.2 Explain the construction of JFET.
- 5.3 Draw the symbols of FETs.
- 5.4 Identify the terminals of FET.
- 5.5 Explain the working of FET.
- 5.6 Explain the drain characteristics of FET.
- 5.7 Explain the mutual characteristics of FET.
- 5.8 Define the parameters of the device.

- 5.9 Establish the relation between them.
- 5.10 List the specifications of JFET.
- 5.11 Identify the applications of FET.
- 5.12 Distinguish between BJT and FET.
- 5.13 What are the advantages of FET over BJT?
- 5.14 What are disadvantages of FET over BJT?

CO6: Classify MOSFETs and compare them.

- 6.1 Define MOSFET.
- 6.2 Classify the different types of MOSFET.
- 6.3 Draw the symbols of MOSFETs.
- 6.4 Identify the terminals of MOSFET.
- 6.5 Explain the working principle of the device.
- 6.6 Explain the construction of the device.
- 6.7 Identify the differences between FETs and MOSFETs..
- 6.8 What are the advantages of MOSFETs?
- 6.9 Explain the construction of depletion MOSFET.
- 6.10 Explain the working of the above.
- 6.11 Explain the construction of enhancement MOSFET.
- 6.12 Explain the working of the above.
- 6.13 Draw the characteristics of depletion MOSFET.
- 6.14 Draw the characteristics of enhancement MOSFET.
- 6.15 Distinguish between enhancement and depletion MOSFET.

Suggested Student Activities

1. Visit the Institute’s Library / internet center and list the books/journals/ e-books and any other resources available on the topics suggested by the teacher.
2. Prepare a chart showing the symbols and names of various devices.
3. Prepare a PPT identifying the need for these semiconductor devices and their use in electronic industry.

CO-PO Mapping Matrix

	Basic and Discipline Specific Knowledge	Problem Analysis	Design/Development of Solutions	Engineering Tools, Experimentation and Testing	Engineering Practices for Society, Sustainability and Environment	Project Management	Lifelong Learning	Linked PO
CO	PO1	PO2	PO3	PO4	PO5	PO6	PO 7	
CO1	2							1,
CO2	2		1			1		1.3.6
CO3	2		1			1		1.3.6
CO4	2		2			1		1.3.6

CO5	2		2			2	1	1,3,6,7
CO6	2		3			2	1	1,3,6,7

QUESTION PAPER PATTERN FOR MID SEMESTER EXAMS

Sl.No	Description	Level	No of Questions	Marks for each question	Choice	Total Marks
01	Part-A	Remembering(R)	4	1	Nil	4 Marks
02	Part-B	Understanding(U)	4	3	2	6 Marks
03	Part-C	Application(A)	4	5	2	10 Marks
Total Marks						20 Marks

MID SEM-I EXAM

S.No	Unit No	R	U	A	Remarks
1	Unit-I	1,2	5(a)	7(a)	
			5(b)	7(b)	
2	Unit-II	3,4	6(a)	8(a)	
			6(b)	8(b)	
Total Questions		4	4	4	

MID SEM-II EXAM

S.No	Unit No	R	U	A	Remarks
1	Unit-III	1,2	5(a)	7(a)	
			5(b)	7(b)	
2	Unit-IV	3,4	6(a)	8(a)	
			6(b)	8(b)	
Total Questions		4	4	4	

The length of answer for each question framed in respect of Part-A, B&C shall not exceed ¼ of a page, 1 page and 2 pages respectively

QUESTION PAPER PATTERN FOR SEMESTER END EXAM

Sl.No	Description	Level	No of Questions	Marks for each question	Choice	Total Marks
01	Part-A	Remembering(R)	8	1	Nil	8 Marks
02	Part-B	Understanding(U)	8	3	4	12 Marks
03	Part-C	Application(A)	8	5	4	20 Marks
Total Marks						40 Marks

Unit No	Questions to be set for SEE				
	R		U	A	
I	Q4	Q1	Q9(a)	Q13(a)	
II					
III		Q2	Q10(a)	Q14(a)	
IV					
V		Q3	Q5,Q6	Q9(b), Q11(a), Q11(b)	Q13(b), Q15(a), Q15(b)
VI					

Total Questions	8	8	8
-----------------	---	---	---

State Board of Technical Education and Training, Telangana
Model Question paper
DECE I semester
Mid Semester-I Examination

Course Code: EC-106

Duration: 1 hour

Course Name: SEMICONDUCTOR DEVICES

Max.Marks: 20 Marks

PART-A

Answer all questions, Each Question carries ONE mark

4x1 = 4 Marks

1. What is an extrinsic Semiconductor?
2. Write 2 examples for acceptor impurity.
3. State 2 specifications of PN diode.
4. Draw the symbols of PN diode and zener diode.

PART-B

Answer TWO questions. Each question carries THREE marks 2x3 = 6 Marks

- 5(a). Explain the formation of P-type semiconductor.
(OR)
- 5(b). Draw the energy level band diagram of semiconductor and insulator.
- 6(a). Draw the V-I characteristics of PN diode.
(OR)
- 6(b). Explain avalanche breakdown.

PART-C

Answer TWO questions. Each question carries FIVE marks 2x5= 10 Marks

- 7(a). Distinguish between P-type and N-type semiconductor.
(OR)
- 7(b). Distinguish between intrinsic and extrinsic semiconductor.
- 8(a). Explain the working principle of zener diode.
(OR)
- 8(b). Explain the working of PN diode under forward bias condition.

State Board of Technical Education and Training, Telangana
Model Question paper
DECE I semester
Mid Semester-II Examination

Course Code: EC-106

Course Name: SEMICONDUCTOR DEVICES

Duration: 1 hour

Max. Marks: 20 Marks

PART-A

Answer ALL questions, Each Question carries ONE mark

4x1 = 4 Marks

1. Draw the symbols of PNP and NPN transistor.
2. Define current gain in CB configuration.
3. What is a filter?
4. Define ripple factor.

PART-B

Answer TWO questions. Each question carries THREE marks.

2x3 = 6 Marks

- 5(a). Draw the input characteristics of BJT in CE configuration.

(OR)

- 5(b). Derive the relation between alpha and beta.

- 6(a). Draw the circuit diagram of HWR, its input and output waveforms.

(OR)

- 6(b). Define cutoff, active and saturation regions.

PART-C

Answer TWO questions. Each question carries FIVE marks

2x5 = 10 Marks

- 7(a). Explain the working of NPN transistor.

(OR)

- 7(b). Compare the performance of CB, CE and CC configurations.

- 8(a). Draw and explain the Block diagram of regulated power supply.

(OR)

- 8(b). Explain the working of bridge rectifier with a neat figure and waveforms.

State Board of Technical Education and Training, Telangana
Model Question paper
DECE IV semester
I Semester End Examination

Course Code: EC-106

Course Name: SEMICONDUCTOR DEVICES

Duration: 2 hours

Max. Marks: 40 Marks

PART-A

Answer all questions. Each Question carries one mark

8x1 = 8 Marks

1. What is doping?
2. Draw the symbols of NPN and PNP transistor.
3. Define ripple factor.
4. Define alpha of BJT.
5. Draw the symbols of n-channel and p-channel FET.
6. Define transconductance.
7. Draw the symbol of n-channel enhancement and depletion MOSFET.
8. Write any 2 advantages of MOSFETs.

PART-B

Answer FOUR questions. Each question carries three marks.

4 x 3 = 12 Marks

- 9(a). Draw the energy band diagrams of conductors, semiconductors and insulators.

(OR)

- 9(b). Draw the drain characteristics of JFET.

- 10(a). Draw the circuit diagram of BJT in CE configuration.

(OR)

- 10(b). Draw the drain characteristics of enhancement MOSFET.

- 11(a). Derive the relation between the parameters of JFET.

(OR)

- 11(b). Draw the mutual characteristics of JFET.

- 12(a). Write any 3 advantages of MOSFETS.

(OR)

- 12(b). Write any 3 differences between JFET and MOSFET.

PART-C

Answer FOUR questions. Each Question carries FIVE marks

4 x 5 = 20 Marks

- 13(a) Explain the working of Zener diode and its characteristics.

(OR)

- 13(b) Explain the construction of enhancement MOSFET.

- 14(a) Explain the working of PNP transistor.

(OR)

- 14(b) Compare MOSFETs and FETs with respect to 5 in number.

- 15(a) Explain the working principle of JFET.

(OR)

- 15(b) Explain the construction of JFET.

- 16(a) Explain the working of depletion MOSFET.

(OR)

- 16(b) Explain the characteristics of depletion MOSFET.

ME-107 : ENGINEERING DRAWING - I

(This Course is Common to all programs of Diploma in Engineering offered by the State Board of Technical Education, Hyderabad, Telangana State)

Course Title :	Engineering Drawing - I	Course Code	ME-107
Semester	I	Course Group	Practical
Teaching Scheme in Periods (L:P)	1:0:2	Credits	1.25
Methodology	Lecture + Practice	Total Contact Periods:	45
CIE	60Marks	SEE	40Marks

Prerequisites: No prerequisites are required to learn this course.

Course Objectives

The Course is aimed at developing basic drawing skills so as to enable them to use these skills in the preparation of engineering drawings, their reading and interpretation.

Course Outcomes

Upon completion of the subject the student shall be able to

CO1	Recognize the importance of Engineering Drawing and usage of the drawing instruments.
CO2	Practice freehand lettering & numbering in different styles.
CO3	Use of different methods of dimensioning systems in Engineering Drawing.
CO4	Construct engineering curves such as parabola, hyperbola, ellipse, involute, cycloid, helix and their tangent lines.
CO5	Apply knowledge of orthographic projection principles to accurately represent the projection of points, lines, and planes onto different planes.
CO6	Explain the principles and conventions of orthographic projection, including the use of multiple views to fully describe an object.

BLUEPRINTFORMARKSINSEE

Unit No	Name of the Unit	Periods	Questions to be set for SEE		
			R	U	A
			PART-A (2MQuestions)		PART-B (6MQuestions)
1, 2 &3	Importance of Engineering Drawing and Instruments, Free Hand lettering and Numbering and Dimensioning Practice	09	Q1	Q9(a)	
4a.	Geometric constructions up to Construction of polygons	06	Q2	Q9(b)	
4b.	Geometric constructions contd., Conical curves and Special curves	06	Q3	Q10(a)	
5	Projection of points, Lines, and Planes	09	Q4	Q10(b)	
6	Ortho graphic projections	15	Q5,Q6, Q7,Q8	Q11(a),Q11(b), Q12(a),Q12(b)	
Total Periods / Total Questions		45	8	4	

[R: Remembering; U: Understanding – 2 Marks; A: Application – 6 Marks]

Note: Question Paper consists PART– A and PART-B

PART–A consists of 8 questions and student has to answer ALL questions, each question Carries 2 marks. (8x2 =16)

PART–B consists of 4 questions and student has to attempt ALL questions, each question carries 6 marks (4x6=24)

CIE Question Paper Pattern and Syllabus

Unit No	Name of the Unit	Periods	Questions to be set for CIE		
			R	U	A
			PART-A(2MQuestions)		PART-B (6MQuestions)
Mid Semester–I Exam					
1, 2 &3	Importance of Engineering Drawing and Instruments, Free Hand lettering and Numbering and Dimensioning Practice	09	Q1,Q2	Q5(a),Q5(b)	
4a.	Geometric constructions upto Construction of polygons	06	Q3,Q4	Q6(a),Q6(b)	
Total			4	2	
Mid Semester –II Exam					
4b.	Geometric constructions contd., Conical curves and Special curves	06	Q1,Q2	Q5(a),Q5(b)	
5	Projection of points, Lines, and Planes	09	Q3,Q4	Q6(a),Q6(b)	
Total			4	2	
<p>[R: Remembering; U: Understanding – 2 Marks; A: Application – 6 Marks]</p> <p><u>Note: Question Paper consists PART– A and PART-B</u> PART–A consists of 4 questions and student has to answer ALL questions, each question carries 2 marks. (4x2 =8) PART–B consists of 2 questions and student has to attempt ALL questions, each question carries 6 marks (2x6=12)</p>					

COURSE CONTENTS

NOTE:

1. B.I.S Specification should invariably be followed in all the topics.
2. A-3 Size Drawing Sheets are to be used for all Drawing Practice Exercises.

1.0 The importance of Engineering Drawing and Engineering Instruments (03periods)

Explanation of the scope and objectives of the subject of Engineering Drawing – Its importance as a graphic communication – Need for preparing drawing as per standards –SP-46–1988–Mention B.I.S–Role of drawing in Engineering education– Link between Engineering drawing and other subjects of study.

Engineering drawing Instruments

Classifications: Basic Tools, tools for drawing straight lines, tools for curved lines, tools for measuring distances and special tools like mini drafter & drafting machine – Mentioning of names under each classification and their brief description -Scales: Recommended scales reduced & enlarged -Lines: Types of lines, selection of line thickness - Selection of Pencils -Sheet Sizes: A0, A1, A2, A3, A4, A5, Layout of drawing sheets in respect of A0, A1, A3 sizes, Sizes of the Title block and its contents, Care and maintenance of Drawing Sheet, Drawing plate: Layout of sheet–as perSP-46-1988to a suitable scale.

2.0 Freehand lettering & numbering (03periods)

Importance of lettering –Types of lettering – Guide Lines for Lettering
Practicing of letters & numbers of given sizes (7mm, 10mm and 14mm)
Advantages of single stroke or simple style of lettering – Use of lettering stencils

3.0 Dimensioning practice (03periods)

Purpose of Engineering Drawing, Need of B.I.S code in dimensioning –Shape description of an Engineering object -Definition of Dimensioning size description - Location of features, surface finish, fully dimensioned Drawing -Notations or tools of dimensioning, dimension line extension line, leader line, arrows, symbols, number and notes, rules to be observed in the use of above tools -Placing dimensions: Aligned system and unidirectional system (SP-46-1988)-Arrangement of dimensions Chain, parallel, combined progressive, and dimensioning by co-ordinate methods-The rules for dimensioning standard, features: Circles (holes) arcs, angles, tapers, chamfers, and dimension of narrow spaces.

4.0 Geometric Construction (12periods)

Division of a line: to divide a straight line into given number of equal parts internally examples in engineering application. Construction of tangent lines: to draw tangent lines touching circles internally and externally.
Construction of tangent arcs

- a) To draw tangent arc of given radius to touch two lines inclined at given angle (acute, right and obtuse angles).
- b) Tangent arc of given radius touching a circle or an arc and a given line.
- c) Tangent arcs of radius R, touching two given circles internally and externally.

Construction of polygon: construction of any regular polygon of given side length using general method.

Conical Curves: Explanation of Ellipse, Parabola, Hyperbola, as sections of a double cone and a loci of a moving point, Eccentricity of above curves – Their Engg. Application viz. Projec tiles, reflectors, P-VDiagram of a hyper bolic process.

Conical Curves: Construction of any conic section of given eccentricity by general method. Construction of ellipse by concentric circles method. Construction of parabola by rectangle method.

Construction of rectangular hyperbola.

Special Curves: Involute, Cycloid and Helix, explanations as locus of a moving point, their engineering application, viz, Gear tooth profile, screw threads, springs etc.-their construction

5.0 Projection of points, lines and planes (09periods)

Projecting a point on two planes of projection -Projecting a point on three planes of projection-Projection of straight line.

- a) Parallel to both the planes.
- b) Perpendicular to one of the planes.
- c) Inclined to one plane and parallel to other planes. Projection of regular planes.
 - a) Plane perpendicular to HP and parallel to VP and vice versa.
 - b) Plane perpendicular to HP and inclined to VP and vice versa.

6.0 Orthographic Projections (15 periods)

Meaning of orthographic projection -Using a viewing box and a model – Number of views obtained on the six faces of the box - Legible sketches of 3 views for describing object -Concept of front view, top view, and side view for sketching these views of engineering objects- Explanation of first angle projection.– Positioning of three views in First angle projection-Projection of points as a means of locating the corners of the surfaces of an object – Use of miter line in drawing a third view whenothertwoviewsaregiven-Methodofrepresentinghiddenlines- Selectionofminimumnumberof views to describe full object.

Reference Books

1. Engineering Drawing by N.D. Bhatt (Charotar Publishing House Pvt. Ltd.)
2. Engineering Drawing by Kapildev–(Asian Publisher)
3. Engineering Drawing by Basant Agarwal & C. M Agarwal- (McGraw-hill)
4. A Text book on Engineering Drawing by P. Kannaiah ,K.L. Narayana, K. Venkata Reddy
5. Engineering drawing + AutoCAD by Venugopal, K, New Delhi : New Age International

Online Resources

1. <https://nptel.ac.in/courses>

2. <https://nptel.ac.in/courses/124107157>
3. www.slideshare.net/shameem.mist/engineering-drawing
4. <https://www.powershow.com/viewfl/76303a->
5. OWI5M/Engineering_Drawing_powerpoint_ppt_presentation
6. <https://www.powershow.com/view0/91a2bf->
7. N2Q2N/Basic_engineering_drawing_solved_question_powerpoint_ppt_presentation

Suggested Learning Outcomes

Upon completion of the subject, the student shall be able to

1.0 Understand the basic concepts of engineering drawing

- 1.1 State the importance of drawing as an engineering communication medium
- 1.2 State the necessity of B.I.S. Code of practice for Engineering Drawing.
- 1.3 Explain the linkages between Engineering drawing and other subjects of study in diploma course.

Use of Engineering Drawing Instruments

- 1.4 Select the correct instruments and draw lines of different orientation.
- 1.5 Select the correct instruments and draw small and large Circles.
- 1.6 Select the correct instruments for measuring distances on the drawing.
- 1.7 Use correct grade of pencil for different types of lines, thickness and given function.
- 1.8 Select and use appropriate scales for a given application.
- 1.9 Identify different drawing sheet sizes as per I.S. and Standard Lay-outs.
- 1.10 Prepare Title block as per B.I.S. Specifications.

2.0 Write FreeHand Lettering and Numbers

- 2.1 Write titles using sloping lettering and numerals of 7mm, 10mm and 14mm height
- 2.2 Write titles using vertical lettering and numerals of 7mm, 10mm and 14mm height
- 2.3 Select suitable sizes of lettering for different layouts and applications
- 2.4 Practice the use of lettering stencils.

3.0 Understand Dimensioning Practice

- 3.1 Define "Dimensioning.
- 3.2 State the need of dimensioning of drawing according to accepted standard.
- 3.3 Identify notations of Dimensioning used in dimensioned drawing.
- 3.4 Identify the system of placement of dimensions in the given dimensioned drawing.
- 3.5 Dimension a given drawing using standard notations and desired system of dimensioning.
- 3.6 Dimensioning standard features applying necessary rules.
- 3.7 Arrange dimensions in a desired method given in a drawing.
- 3.8 Identify the departures if any made in the given dimensioned drawing with reference to SP-46-1988, and dimension the same correctly.

4.0 Apply Principles of Geometric Constructions

- 4.1 Divide a given line into desired number of equal parts internally.

- 4.2 Draw tangent lines and arcs.
- 4.3 Use General method to construct any polygon.
- 4.4 Explain the importance of conics.
- 4.5 Construct conics (ellipse, parabola and hyperbola) by general method.
- 4.6 Construct ellipse by concentric circles method.
- 4.7 Construct parabola by rectangle method.
- 4.8 Construct rectangular hyperbola from the given data.
- 4.9 Construct involute from the given data.
- 4.10 Construct cycloid and helix from the given data.
- 4.11 State the applications of the above constructions in engineering practice.

5.0 Apply Principles of Projection of points, lines and planes (06Hours)

- 5.1 Visualize the objects
- 5.2 Explain the I-angle and III-angle projections
- 5.3 Practice the I-angle projections
- 5.4 Draw the projection of a point with respect to reference planes (HP&VP)
- 5.5 Draw the projections of straight lines with respect to two reference Planes (upto lines parallel to one plane and inclined to other plane)
- 5.6 Draw the projections of planes (up to planes perpendicular to one plane and inclined to other plane)

6.0 Apply principles of orthographic projection

- 6.1 Explain the principles of orthographic projection with simple sketches.
- 6.2 Draw the orthographic view of an object from its pictorial drawing.
- 6.3 Draw the minimum number of views needed to represent complete engineering component.

COURSEOUTCOMES (CO)

Upon successful completion of the course, the students will be able to

Course Outcome		Cognizant Level	Linked Program Objectives (PO)
CO1	Recognize the importance of Engineering Drawing and usage of the drawing instruments.	R	1, 4, 7
CO2	Practice free hand lettering & numbering in different styles.	R/U	1, 3, 4, 7
CO3	Use of different methods of dimensioning systems in Engineering Drawing.	R/U	1,3, 4, 7
CO4	Construct engineering curves such as parabola, hyperbola, ellipse, involute, cycloid, helix and their tangent lines.	R/U/A	1, 2, 3, 4, 7

CO5	Apply knowledge of orthographic projection principles to accurately represent the projection of points, lines, and planes onto different planes.	R/U/A	1, 2, 3, 4,6, 7
CO6	Explain the principles and conventions of orthographic projection, including the use of multiple views to fully describe an object.	R/U/A	1, 2, 3, 4, 7

CO-POMATRIX:

CO	PO1	PO2	PO3	PO4	PO5	PO6	PO7
CO1	3	-	-	3	-	-	3
CO2	3	1	2	2	-	-	3
CO3	3	1	2	2	-	-	2
CO4	3	1	2	2	-	-	2
CO5	3	3	2	2	-	1	1
CO6	3	1	3	3	-	-	2

**BOARD DIPLOMA EXAMINATION, (C-24)DME- I SEMESTER
ME-107, MID SEMESTER - I
EXAMINATIONENGINEERING
DRAWING - I**

Time:1Hour]

[TotalMarks:20

PART-A

04x02=08

Instructions : 1. Answer **ALL** questions.
2. Each question carries **TWO** marks.

1. Write freehand the following, using single stroke vertical capital letters of height 12 mm. 'NECESSITY IS THE MOTHER OF INVENTION'
2. Redraw the following figure in Uni-Directional system of dimensioning.

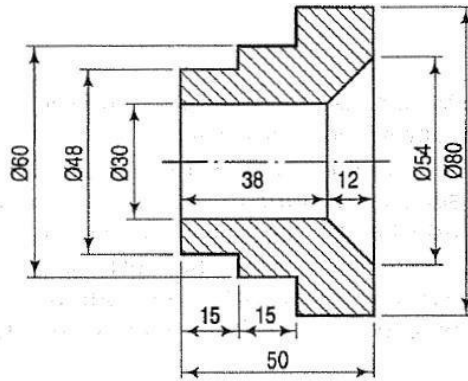

3. To divide a straight line of 70 mm into 6 equal parts.
4. Bisect a given line AB of length 75 mm.

PART-B

02x06=12

Instructions : 1. Answer **ALL** questions.
2. Each question carries **SIX** marks.

5. (a) Redraw the following figure with chain dimensioning.

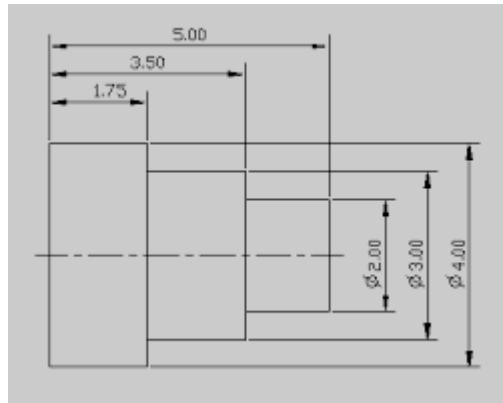

(Or)

5. (b) Redraw the following figure in aligned system of dimensioning.

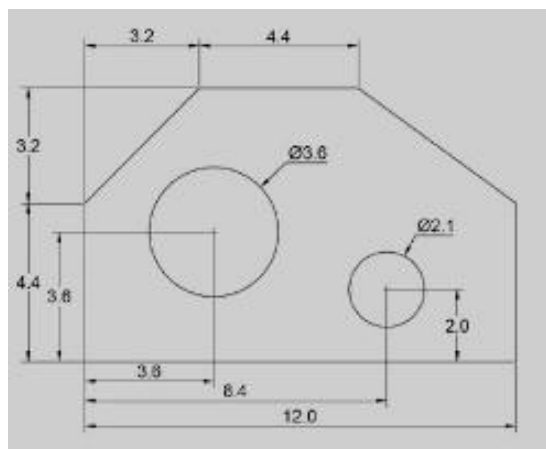

6. (a) Construct a regular pentagon of base side 30 mm in general method.

(Or)

6. (b) Draw an arc of radius 30 mm touching the given straight line AB of length 70 mm and passing through a point 'P' which is 55 mm above the line AB.

**BOARD DIPLOMA EXAMINATION, (C-
24)DME– I SEMESTER
MID SEMESTER - II
EXAMINATION ENGINEERING
DRAWING - I**

Time:1Hour]

[TotalMarks:20

PART-A

04x02=08

- Instructions :**
1. Answer **ALL** questions.
 2. Each question carries **TWO** marks.
1. Draw an arc of radius 30 mm touching the two given straight lines AB and AC making an angle 45° with each other.
 2. Draw an internal common tangent for the two given circles of equal radius of 30 mm if the centre distance is 75 mm.
 3. Draw the projections of a point A lying on both the planes.
 4. A line AB of length 70 mm is parallel to V.P. and inclined at an angle of 30° to H.P. Draw its projections when its end A is on the H.P. and 20 mm in front of V.P.

PART-B

02x06=12

- Instructions :**
1. Answer **ALL** questions.
 2. Each question carries **SIX** marks.
5. (a) Construct an ellipse if the distance between focus and the directrix is 50 mm by eccentricity method. Also draw the normal and tangent at any point on the curve.
(Or)
 5. (b) Construct the locus of a point 'P' which is on the circumference of circle of radius 25 mm when it is rolling on a straight line for one complete revolution without slipping. Also name the curve.
 6. (a) Draw the projections of a line AB of length 75 mm parallel to HP and inclined at an angle of 30° to VP. The end A is 30 mm from both the reference planes.
(Or)
 6. (b) A square of base side 40 mm is perpendicular to both the reference planes. Draw its projections.

MODEL PAPER SEE
BOARD DIPLOMA EXAMINATION, (C-24)
DME- I SEMESTER END EXAMINATION
ENGINEERING DRAWING - I

Time: 2 hours]

[Total Marks: 40

Important Note: Wherever any question has choice, marks will be allotted only to first attempted question. No marks will be allotted for extra questions answered.

PART-A

08x02=16

Instructions :

1. Answer **ALL** questions.
2. Each question carries **TWO** marks.
3. All the dimensions are in mm.
1. Write the following, using single stroke vertical capital letters of size 10 mm: 'DEVELOP AN ATTITUDE OF GRATITUDE'
2. Bisect the given angle of 55° .
3. Inscribe a pentagon in a given circle of radius 35 mm.
4. Draw the projections of a point 'P' lying on HP and 30 mm behind VP.
5. Draw the top view of a circular plane of diameter 50 mm when its plane is perpendicular to HP.
6. Draw the projections of a cube of base side 30 mm when it is resting on one of its bases on HP with one of its vertical faces parallel to VP.
7. Draw the front view of the block shown in figure

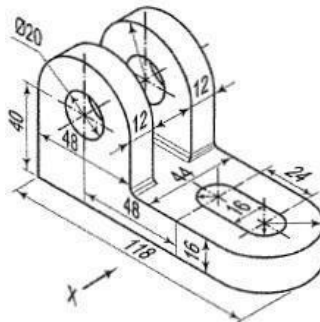

8. Draw the front view of the block shown in figure

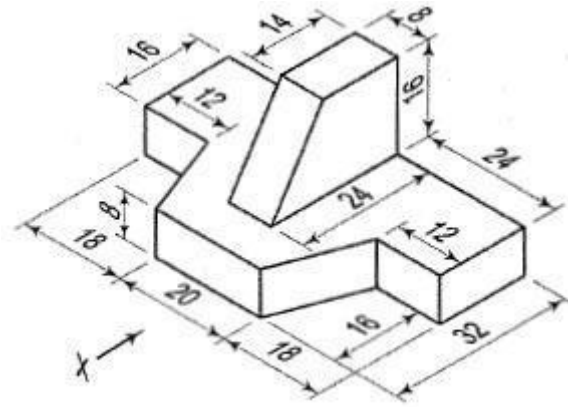

PART-B

04x06=24

- Instructions :**
1. Answer ALL questions.
 2. Each question carries SIX marks.
 3. All the dimensions are in mm.

9. (a) Redraw the following figure with aligned system of dimensioning.

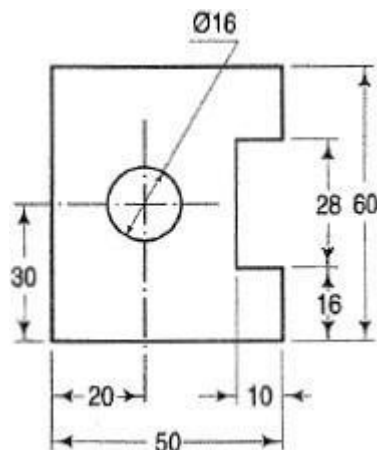

(Or)

9. (b) Inscribe a hexagon in a given circle of radius 30 mm by keeping one of its sides horizontal.
10. (a) Draw a parabola with the distance of the focus from the directrix at 50 mm using eccentricity method and draw a normal and tangent through a point 40 mm from the directrix. (Or)
10. (b) A line AB 75 mm long is parallel to H.P. and inclined at 30° to V.P. The end A is 25 mm above H.P. and 30 mm in front of V.P. Draw its projections.
11. (a) Draw the front view of the component shown in figure

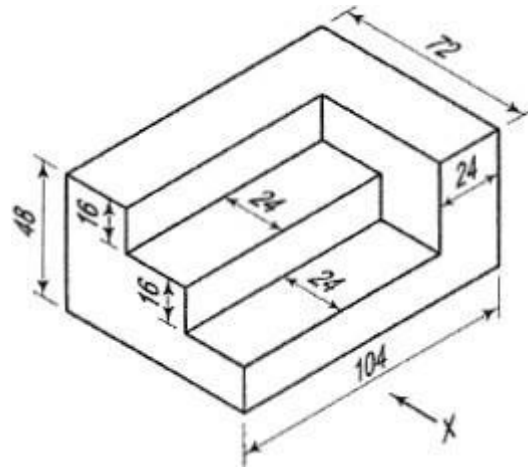

(Or)

11. (b) Draw the top view from the component as shown in figure.

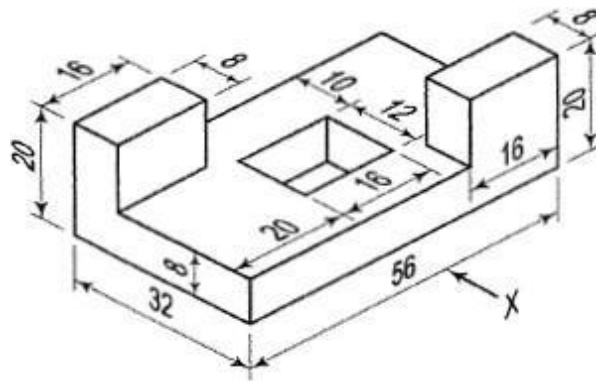

12. (a) Draw the front view of component shown in figure

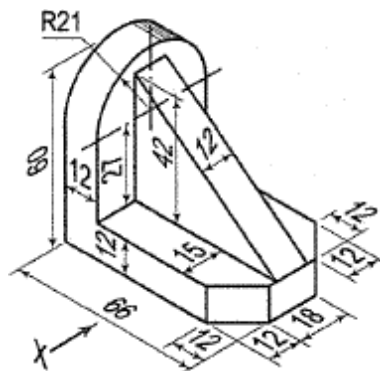

(Or)

12(b) Draw the top view and front view of the component as shown in figure

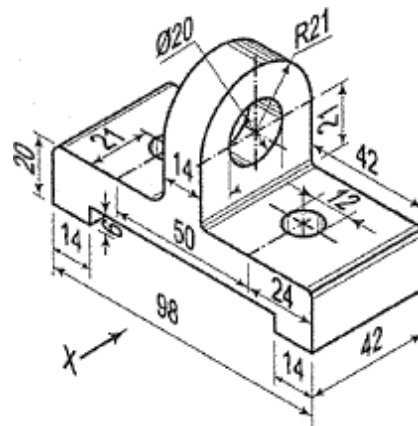

EC-108 : BASIC ELECTRONICS LAB

Course Title:	Basic Electronics lab	Course Code :	EC-108
Semester:	I Semester	Course Group :	Practical
Teaching Scheme in Periods(L:T:P):	1:0:2	Credits :	1.25
Methodology :	Lecture+ Practical	Total Contact Periods :	45 Periods
CIE :	60 Marks	SEE :	40 Marks

Pre requisites

Course Outcomes

This course requires the basic knowledge of electrical engineering and semiconductor devices

On completion of the course, the student should be able to;

CO1	Identify and test the various electronic components
CO2	Plot the characteristics of semiconductor devices
CO3	Analyze the different packages and types of semiconductor devices and components.

Course Content and Blue Print of Marks for SEE

Unit No	Unit Name	Periods	Questions to be set for SEE		
			R	U	A
1	Identify the various electronic components and test them.	9			
2	Plot the characteristics of semiconductor devices	30			
3	Analyze the different packages and types of semiconductor	6			

	devices and components.				
	Total	45			

Suggested E-learning references

1. <http://nptel.ac.in>
2. <https://www.youtube.com>

Suggested Learning Outcomes

**Upon
compl**

ation of the course, the student shall be able to

1. Identify and test different types of active and passive components.
2. Study and observe the front panel controls of CRO.
3. Study and observe the front panel controls of RF signal generator.
4. Test the given transformer and find the turns ratio.
5. Measure the value of colour coded resistors and verify theoretically.
6. Determine the equivalent resistance in series connection and verify theoretically.
7. Determine the equivalent resistance in parallel connection and verify theoretically.
8. Connect a series parallel circuit, measure the voltage and current, verify theoretically.
9. Identify the terminals of PN diode, Zener diode and BJT with a multimeter.
10. Test the given p-n diode and BJT.
11. Obtain the forward bias characteristics of PN diode and calculate its forward resistance from graph.

12. Obtain the reverse bias characteristics of PN diode and calculate its reverse resistance from graph.
13. Plot the characteristics of Zener diode.
14. Plot the input characteristics of BJT in CE configuration.
15. Plot the output characteristics of BJT in CE configuration.
16. Draw the output waveforms of HWR without filter.
17. Draw the output waveforms of FWR without filter.

CO-PO Mapping Matrix

	Basic and Discipline Specific Knowledge	Problem Analysis	Design/Development of Solutions	Engineering Tools, Experimentation and Testing	Engineering Practices for Society, and Sustainability and Environment	Project Management	Lifelong Learning	Linked PO
CO	PO1	PO2	PO3	PO4	PO5	PO6	PO 7	
CO1	3		2	1		1	3	1,3,4,6,7
CO2	3		2	1		3	3	1,3,4,6,7
CO3	3		2	1		1	3	1,3,4,6,7

QUESTION PAPER PATTERN FOR MID SEMESTER EXAMS

Sl.No	Description	Level	No of Questions	Marks for each question	Choice	Total Marks
01	Part-A	Remembering(R) and Understanding(U)	2	4	Nil	8 Marks

02	Part-B	Application(A)	2	12	1	12 Marks
Total Marks						20 Marks

QUESTION PAPER PATTERN FOR SEMESTER END EXAM

Sl.No	Description	Level	No of Questions	Marks for each question	Choice	Total Marks
01	Part-A	Remembering(R) and Understanding(U)	4	4	Nil	16 Marks
02	Part-B	Application(A)	2	24	1	24 Marks
Total Marks						40 Marks

SC-109 : BASIC SCIENCE LAB

Course Title	Basic Science Lab	Course Code	SC-109
Semester	I Semester	Course Group	Practical
Teaching Scheme in Periods (L:T:P)	15:0:30	Credits	1.25
Type of course	Lecture + Practical	Total Contact Periods	45 Periods
CIE	60 Marks	SEE	40 Marks

SC-109 (A) :PHYSICS LAB

Pre requisites:

This course requires the basic knowledge of Science and Mathematics.

Course Outcomes

On completion of the course, the student shall be able to

CO1	Demonstrate the principle of Screw Gauge and calculate accurate measurement of thickness of glass plate and area of cross section of a wire.
CO2	Make use of laws of vector addition to verify Parallelogram law of forces and Triangle law of forces.
CO3	Determine the coefficient of friction between wood and wood and wood and glass surfaces on horizontal plane.
CO4	Calculate coefficient of viscosity of a liquid by capillary method.
CO5	Make use of Quill tube to verify Boyle's law.
CO6	Calculate the surface tension of water using capillary rise method. (Demonstration only)

	Basic and Discipline Specific Knowledge	Problem Analysis	Design/Development of Solutions	Engineering Tools, Experimentation and Testing	Engineering Practices for Society, Sustainability and Environment	Project Management	Lifelong Learning	Linked PO
CO	PO1	PO2	PO3	PO4	PO5	PO6	PO 7	
CO1	3					1	1	1,6,7
CO2	3					1	1	1,6,7
CO3	3					1	3	1,6,7
CO4	3					1	3	1,6,7
CO5	3					1	3	1,6,7

Learning outcomes

On successful completion of the course, the student will have ability to:

1. Demonstrate the principle of Screw Gauge and calculate accurate measurement of thickness of glass plate and area of cross section of a wire.
2. Make use of laws of vector addition to verify Parallelogram law of forces and Triangle law of forces.
3. Determine the coefficient of friction between wood and wood and wood and glass on horizontal plane.
4. Calculate coefficient of viscosity of a liquid by capillary method.
5. Make use of Quill tube to verify Boyle's law.

Demonstration Experiment:

1. Calculate the surface tension of water using capillary rise method.

Course Delivery:

The course will be delivered through lectures, class room interaction, group discussions, graded exercises, demonstration and practice.

Tutorial: 1Period /Experiment:

1. Introduction to Physics practical and its importance, safety precautions in maintenance of equipment in the laboratory.
2. Maintenance of apparatus and equipment.
3. Follow of Do's and Don'ts.

4. Maintenance of data in manual and record book.
5. Write the procedure of the experiment before the commencement of each experiment.
6. Strictly following of instructions given from time to time by the lecturer-in-charge.
7. Demonstration of each experiment by the lecturer in charge.

Conduction of experiments: 2 periods/Experiment.

Student must perform experiment individually under the supervision of the lecturer-in charge.

EXAMINATION & EXPERIMENTS		
S.NO	EXAMINATION	EXPERIMENTS
1	MIDSEM-I	EXPERIMENT NO 1 & 2
2	MIDSEM-II	EXPERIMENT NO 3 & 4
3	SEMESTER END EXAMINATION	EXPERIMENT NO 1,2,3,4 and 5

Scheme of Valuation of SEE		
S.No	Particulars	Marks
1.	Objective/Aim	01
2.	Apparatus/Equipment	02
3.	Observations	02
4.	Principle including formula	02
5.	Experiment (Tabular form, readings, etc)	05
6.	Calculation and Result	05
7.	Viva Voce	03
	Total	20

References:

1. Intermediate Physics lab manual – Telugu Academy
2. Laboratory manual for class XI and XII – NCERT

SC-109 (B):CHEMISTRY LAB

Prerequisite: Knowledge of basic concepts of Chemistry of secondary education

Course Objectives: To provide practical knowledge about the basics of preparation of chemical solutions and volumetric analysis of chemical compounds.

Course Outcomes: On successful completion of the course, the student will have ability to attain CO:

Course Outcome	
CO1	Prepare the primary standard solution to find out the concentrations of unknown solution.
CO2	Estimate the amount of the HCl in the given sample of solutions by volumetric analysis.
CO3	Estimate the amount of the NaOH in the given sample of solutions by volumetric analysis.
CO4	Find the pH of the unknown solutions collected from different industrial areas and recommend a remedial action.
CO5	Determine the hardness of water sample and recommend a solution for identified hardness

CO	PO1	PO2	PO3	PO4	PO5	PO6	PO7
CO1	3	-	-	1	-	1	1
CO2	3	-	-	-	-	1	1
CO3	3	-	-	-	-	1	1
CO4	3	-	-	2	2	1	1
CO5	3	-	-	-	2	1	1

Course Delivery:

The course will be delivered through lectures, classroom interactions, group discussions, demonstrations and practicals.

Conduction of experiments: Lecture 1 period + Experiment 2 periods.

Student must conduct experiment individually under the supervision of the staff -in-charge.

Lecture and Demonstration: 1 Period

1. Introduction of chemistry practical and its importance, safety precautions in maintenance of cleanliness and orderliness of chemicals in the laboratory.
2. Maintenance of apparatus and equipment.

3. Follow of Do's and Don'ts.
4. Maintenance of data in record book.
5. Write the procedure of the experiment before the commencement of each experiment.
6. Strict following of instructions given from time to time by the staff-in-charge.
7. Demonstration of each experiment by the staff in charge.

Course Content

Volumetric Analysis: (22.5 Periods)

Volumetric Analysis by Titrimetric Method:

Volumetric Analysis -Titration – Standard Solutions - Concentration of solutions -Indicators
- Acid base indicators - Selection of indicators – Endpoint of titration-Neutralization-
Harness of water

List of experiments:

1. Preparation of primary standard solution.
2. Estimation of hydrochloric acid by using standard basic solution
3. Estimation of sodium hydroxide by using standard acidic solution.
4. Standardisation of disodium salt of EDTA using standard magnesium sulphate solution.
5. Determination of total hardness of water sample by EDTA method.

Specific Learning Outcomes

Upon completion of the course, the student will have ability to

1. Prepare standard sodium carbonate solution and dilute to desired concentration.
2. Estimate hydrochloric acid present given volume of solution by using standard sodium carbonate solution.
3. Estimate sodium hydroxide present in the given volume of solution by using standard hydrochloric acid solution.
4. Standardisation of disodium salt of EDTA using standard magnesium sulphate solution.
5. Determine the total hardness of watersamplebyusing0.02N disodium salt of EDTA solution.

Reference Books:

1. Vogel's Inorganic Qualitative and Quantitative Analysis.
2. Practical chemistry by O.P. Pande & others.
3. Intermediate Chemistry Lab manual-Telugu academy (Telangana state)

EXAMINATION&EXPERIMENTS		
S.NO	EXAMINATION	EXPERIMENTS
1	MIDSEM-I	ExperimentNo. 1 &2
2	MIDSEM-II	ExperimentNo. 3 &4
3	SEMESTEREND EXAMINATION	ExperimentNo. 1,2,3,4and 5

Schemeof ValuationforSEE		
Sl.No.	Particulars	MARKS
1	Identificationofapparatus/equipment/chemicalcompo unds/tools/etc.	2
2	WritingPrincipleandProcedure	5
3	ExperimentandObservations	6
4	CalculationandResults	4
5	Viva-voice	3
Total		20

BOARD DIPLOMA EXAMINATION, (C-24)
MIDSEM – I
FIRST SEMESTER EXAMINATION
SC-109 - BASIC SCIENCE LAB

TIME: 1 Hour

TOTAL MARKS: 20

- Instructions:** (1) Answer both PART-A AND PART-B on separate answer sheets.
- (2) Each question carries **TEN** marks.

PART-A (PHYSICS LAB)

Perform ONE experiment allotted by the examiner. 1 x 10 = 10

1. Determine the thickness of given glass plate using Screw gauge.
2. Find the cross sectional area of given wire using Screw gauge.
3. Verify parallelogram law of forces.
4. Verify triangle law of forces.

PART-B (CHEMISTRY LAB)

Perform ONE experiment allotted by the examiner. 1 x 10 = 10

1. Prepare 250ml of 0.05M sodium carbonate solution.
2. Estimate the amount of hydrochloric acid present in 500ml of the given solution using 0.02M sodium carbonate solution.
3. Estimate the amount of hydrochloric acid present in 250ml of the given solution using 0.05M sodium carbonate solution.

BOARD DIPLOMA EXAMINATION, (C-24)
MIDSEM – II
FIRST SEMESTER EXAMINATION
SC-109 - BASIC SCIENCE LAB

TIME: 1 Hour

TOTAL MARKS: 20

- Instructions:** (1) Answer both PART-A AND PART-B on separate answer sheets.
(2) Each question carries **TEN** marks.

PART-A (PHYSICS LAB)

Perform ONE experiment allotted by the examiner. 1 x 10 = 10

1. Determine the coefficient of friction between wooden surface and wooden block.
2. Determine the coefficient of friction between glass surfaces and wooden block.
3. Determine coefficient of viscosity of water using capillary method.

PART-B (CHEMISTRY LAB)

Perform ONE experiment allotted by the examiner. 1 x 10 = 10

1. Estimate the amount of NaOH present in 500 ml solution using 0.02M HCl solution
2. Estimate the amount of NaOH present in 750ml solution using 0.02M HCl solution
3. Find out the Normality of EDTA solution using 0.02N MgSO₄ solution

BOARD DIPLOMA EXAMINATION, (C-24)
SEMESTER END EXAMINATION
FIRST SEMESTER EXAMINATION
SC-109 - BASIC SCIENCE LAB

Time: 2 Hours]

[Total Marks: 40

Instructions: (1) Answer both PART-A AND PART-B on separate answer sheets.
(2) Each question carries **TWENTY** marks.

PART-A (PHYSICS LAB)

Perform ONE experiment allotted by the examiner.

1 x 20 = 20

1. Determine the thickness of given glass plate using Screw gauge.
2. Find the cross sectional area of given wire using Screw gauge.
3. Verify parallelogram law of forces.
4. Verify triangle law of forces.
5. Determine the coefficient of friction between wooden surface and wooden block.
6. Determine the coefficient of friction between glass surfaces and wooden block.
7. Determine coefficient of viscosity of water using capillary method.
8. Verify Boyle's law using Quill tube.

PART-B (CHEMISTRY LAB)

Perform ONE experiment allotted by the examiner.

1 x 20 = 20

1. Prepare 250 ml of 0.05 M sodium carbonate solution.
2. Estimate the amount of hydrochloric acid present in 500 ml of the given solution using 0.02 M sodium carbonate solution.
3. Find the Molarity and estimate the amount of NaOH present in 100 ml of the given solution using 0.01 M HCl solution.
4. Find out the Normality of EDTA solution using 0.02 N $MgSO_4$ solution
5. Determine the total hardness of the given water sample using 0.02 N EDTA solution.

CS-110 : COMPUTER FUNDAMENTALS LAB

Course Title:	Computer Fundamentals Lab	Course Code	CS-110
Semester	I Semester	Course Group	Practical
Teaching Scheme in Periods (L:T:P)	1:0:2	Credits	1.25
Methodology	Lecture+Tutorials	Total Contact Periods	45
CIE	60 Marks	SEE	40 Marks

Pre-requisite: The students should have basic knowledge of English

Pre-requisite: The students should have basic knowledge of using computer

COURSE OUTCOME

CO1	Creating and saving a document, Formatting of text in MS-WORD
CO2	Spell checking, Mail merging and Printing of Documents in MS-WORD
CO3	Creating and Saving a presentation, inserting text and pictures & Formatting the text and pictures, Slide transition and Animation effects in MS-POWER POINT
CO4	Building Worksheet & Charts InMs-Excel and Printing Of Worksheet
CO5	Creating Database, Tables, Forms, Queries, Reports InMs-Access

Course Contents

Unit-I:Creating, Saving a document, Formatting of text in MS-WORD Duration: 5 hrs

MS_WORD - Creating and saving a document, Formatting of text

Unit-II: Spell checking, Mail merging and Printing of Documents in MS-WORD MS Word

Duration: 10 hrs

MS-WORD - Spell Checking - Mail merging - Printingof Documents

Unit-III: Creating and saving a presentation in MS Powerpoint and Slide transition and Animation effects

Duration: 10 hrs

MS-POWER POINT - Creating and saving a presentation - Inserting text and pictures - Formatting the text and pictures- MS-POWER POINT - Effects of slide transition - Animation effects - Slide show & views of slides

Unit-IV Building & Charts in MS-Excel and Printing Of Worksheet

Duration: 10 hrs

Building Worksheets – Building Charts, Printing EXCEL Worksheet

Unit-V Creating Database, Tables, Queries, Forms ,Reports& Printing

Duration: 10 hrs

Creating Table, Viewing(ACCESS) – Creating Forms – Creating Queries and Viewing Database
Creating of ACCESS Reports – Printing of ACCESS Tables, Forms, Reports

Specific Learning Outcomes:

1.0 Practice Operation of MS-Word.

- 1.1 Demonstrate starting MS word.
- 1.2 Identify the word screen elements.
- 1.3 Identify the tool bars on the screen.
- 1.4 Demonstrate loading different tool bars for their functionality.
- 1.5 Identify the drop down menus of the main menu and their functionality.
- 1.6 Demonstrate creating a sample text.
- 1.7 Demonstrate text formatting.
- 1.8 Demonstrate page formatting.
- 1.9 Demonstrate selecting, deselecting the text from menu and Copying.
- 1.10 Demonstrate importing text from other packages.

2.0 Spell checking, Mail merging and Printing of Documents in MS-WORD

- 2.1 Demonstrate search and replace of text.
- 2.2 Demonstrate spell checking.
- 2.3 Demonstrate creating tables.
- 2.4 Demonstrate mail merging of documents.
- 2.5 Demonstrate printing documents, merge printing of documents.
- 2.6 Demonstrate word procedure for importing figures, charts from other installed software.

3.0 Practice operation of MS-Power Point and Slide transition and Animation effects.

- 3.1 Demonstrate starting MS Power Point.
- 3.2 Identify the opening screen elements.
- 3.3 Identify the tool bars in the opening screen.
- 3.4 Demonstrate the selection of the methods of creating a new presentation.
- 3.5 Identify the different Auto Layouts of a slide.
- 3.6 Demonstrate creating a new slide
- 3.7 Demonstrate inserting a new slide.
- 3.8 Demonstrate slide transition effects.
- 3.9 Demonstrate a slide show.

- 3.10 Demonstrate animation effects.
- 3.11 Demonstrate creating an organization chart.
- 3.12 Identify the different slide views.

4.0 Building Worksheets & Charts in MS-Excel

- 4.1 Start EXCEL from the start
- 4.2 Identify the various parts of the window.
- 4.3 Identify the tabs and groups in ribbon layout
- 4.4 Identify and customizing the quick access toolbar
- 4.5 Identify the office button and commands of the drop down menu.
- 4.6 Practice loading of the existing worksheet or create a new worksheet.
- 4.7 Practice entering into the worksheet.
- 4.8 Practice formatting the cells.
- 4.9 Practice formatting the texts in the cells.
- 4.10 Practice changing the height and width of the cells.
- 4.11 Practice freezing the rows, columns.
- 4.12 Practice splitting the screens.
- 4.13 Enter formulas into the cells.
- 4.14 Enter formulas with built in functions.
- 4.15 Create a range name for the cells for group operations.
- 4.16 Create graph for the data in the worksheet.

5.0 Creating Database, Tables, Queries and Forms

- 5.1 Practice loading Ms Access from the start menu.
- 5.2 Create a database table using Database Wizard.
- 5.3 Enter data into the table.
- 5.4 Edit data in the table.
- 5.5 View data from the database.
- 5.6 Design a query.
- 5.7 View data using the query.
- 5.8 Demonstrate creating Forms.
- 5.9 View the database through Forms.
- 5.10 Practice navigating through the database through Forms.
- 5.11 Practice creating Custom Form using Forms Wizard.
- 5.12 Practice creating Reports using the Report Wizard.
- 5.13 Practice printing the tables, forms and reports.

EXERCISES

1. Create and save a document using MS WORD.
2. Format the Text document.
3. Change the page set-up and Insert Header/Footer.
4. Spell checking in the document.
5. Print the document.
6. Create main document and data file for mail merging.
7. Print the document with mail merging.
8. Create a table in the document.
9. Add row, column to a table.
10. Create and save a new presentation using MS Power Point.
11. Choose Auto Layout for a new slide.
12. Inserting text and pictures into a blank slide.
13. Inserting new slides into the presentation.
14. Applying slide transition effects.
15. Demonstrate a slide show.
16. Set animation to text and pictures in a slide.
17. Set the sounds, order and timing for animation.
18. Create and save a new work book in Excel
19. Operating Mouse to selecting tabs, groups, cells, group of cells
20. Entering and editing Data into Worksheet
21. Formatting the text in the cells
22. Formatting the numbers in the cells.
23. Changing the height and width of cells.
24. Freezing Titles, splitting screen
25. Enter formulae for calculation in the cells.
26. Copying the formula over a range of cells.
27. Inserting built-in functions in to the cells.
28. Create graphs for the data using Chart Wizard.
29. Practice Data Forms in Excel.
30. Printing of worksheet
31. Creating Tables using wizard in Access
32. Creating Tables using Design View in Access.
33. Entering Data into tables
34. Viewing the data in table.
35. Creating a new query using wizard.
36. Creating a new query using design view.
37. Viewing the data using a Select Query.
38. Updating the data in table using Update Query.
39. Linking two Tables on Relational Aspect.

40. Create forms using Form Wizard.
41. Create reports using Report Wizard.
42. Printing the tables, forms and reports

Suggested Student Activities

1. Student visits Library to refer to Manual for the specifications
2. Student inspects the available equipment in the Lab to identify the components
3. Visit nearby Industry to familiarize with fabrication techniques
4. Analyze the connections in the UPS available in the Institution facility
5. Quiz , Group discussion, Surprise test

RECOMMENDED BOOKS:

1. Teach yourself Office 2007 for Windows – Coray Sandler, Tom Badgett, Jan Weingarten, BPB Publications.
2. The ABC s of MS Office 2007– Guy Hard-Davis, BPB Publications.
3. Working in MS Office - Ran Mansfield, Tata McGraw Hill Publications.

Student E-Learning reference

1. <https://www.tutorialspoint.com/word/index.htm>
2. <https://www.tutorialspoint.com/powerpoint/index.htm>

CO-PO Mapping Matrix

	Basic and Discipline Specific Knowledge	Problem Analysis	Design/Development of Solutions	Engineering Tools, Experimentation and Testing	Engineering Practices for Society, Sustainability and Environment	Project Management	Lifelong Learning	Linked PO
CO	PO1	PO2	PO3	PO4	PO5	PO6	PO 7	PO
CO1	3	1						1,2
CO2	3	2	1					1,2,3
CO3	3	1						1,2
CO4	3	1	2	2				1,2,3,4

CO5	3	1	2	1				1,2,3,4
------------	---	---	---	---	--	--	--	---------

MODEL QUESTION PAPERS
STATE BOARD OF TECHNICAL EDUCATION & TRAINING:TS, HYDERABD
CS-110 Computer Fundamentals Lab
I-SEMESTER, MID -I MODEL PAPER

TIME: 1 hr

MARKS: 20

ANSWER ANY ONE QUESTION.

EACH QUESTION CARRIES TWENTY MARKS. $20 \times 1 = 20$

1. Demonstrate Starting MS word and identify the word screen elements.
2. Draw and explain the groups and commands in Home tab under ribbon in Ms word.
3. Demonstrate text formatting in Ms word.
4. Demonstrate procedure for checking of spelling and grammar using dictionaries.
5. Demonstrate paragraph formatting in Ms word.
6. Draw and explain the groups and commands in page layout tab under ribbon in Ms word.
7. Demonstrate page formatting in Ms word.
8. Demonstrate procedure for creating Mail merging process in Ms word.
9. Demonstrate creating of table and adding rows and columns to the existing table in Ms word.
10. Demonstrate finding and replacing of text & searching for a bookmark.
11. Demonstrate starting of MS Power Point and identify the opening screen elements.
12. Draw and explain the groups and commands in Home tab under ribbon in MS Power Point.
13. Demonstrate different Auto Layouts of a Slide in MS Power Point.
14. Demonstrate Slide Transition effects in Ms Power Point.
15. Demonstrate different Animation effects in Ms Power Point.
16. Draw and explain the groups and commands in Animations tab under ribbon in MS Power Point.
17. Demonstrate different Slide views in MS Power Point.
18. Draw and explain the groups and commands in Review tab under ribbon in MS Power Point.
19. Demonstrate inserting and formatting of text and pictures in MS Power Point.

MODEL QUESTION PAPERS
STATE BOARD OF TECHNICAL EDUCATION & TRAINING:TS, HYDERABD
CS-110 Computer Fundamentals Lab
I -SEMESTER, MID -II MODEL PAPER

TIME: 1 hr MARKS: 20

ANSWER ANY ONE QUESTION.

EACH QUESTION CARRIES TWENTY MARKS. 20 x 1 = 20

1. Write procedure to open Excel window and Draw and label the parts in Excel window.
2. Draw and Write about groups and commands under Formulas tab under the ribbon in MS-Excel.
3. Write procedure to format the text in the cells.
4. Write procedure to enter formulas with built in functions.
5. Write procedure for creating chart in MS-excel.
6. Write Procedure for formatting numbers in MS-Excel.
7. Write procedure for writing criteria and extract the data.
8. Write procedure for printing of a worksheet.
9. Write procedure for formatting of chart in Ms-excel.
10. Write procedure to jump to different workbooks & import worksheet from different workbook.
11. Write procedure to create a database.
12. Write procedure to create a table using design view.
13. Write procedure to create form using forms wizard.
14. Write procedure for creating reports using report wizard.
15. Write procedure for creating a Custom Form.
16. Write the procedure to create custom reports.
17. Write the procedure to print active sheet.
18. Write the procedure for Printing of reports.
19. Draw and explain the groups and commands in create tab under ribbon in Ms access.
20. Write the procedure for creating Filter by form.

MODEL QUESTION PAPERS
STATE BOARD OF TECHNICAL EDUCATION & TRAINING:TS, HYDERABD
CS-110 Computer Fundamentals Lab
I-SEMESTER, END SEMESTER MODEL PAPER

TIME: 2hr

MARKS: 40

ANSWER ANY ONE QUESTION.

EACH QUESTION CARRIES TWENTY MARKS.

20 x 1 = 20

1. Write procedure for Creating and saving a document and draw and label the different parts of opening screen elements in Ms word.
2. Draw and explain the groups and commands in Home tab under ribbon in MS Power Point.
3. Write procedure for applying sounds, order, timing and effects of animation in a presentation.
4. Write procedure for character formatting in Ms word.
5. Draw and explain the groups and commands in Home tab under ribbon in Ms word.
6. Write procedure for creating main document and data file for mail merging.
7. Write procedure for page formatting in Ms word.
8. Write procedure for checking spelling and grammar using dictionary in Ms word.
9. Write procedure for printing of document in Ms word.
10. Draw and explain the groups and commands in Animations tab under ribbon in MS Power Point.
11. Write procedure to open Excel window and Draw and label the parts in Excel window.
12. Draw and Write about groups and commands under Formulas tab under the ribbon in MS-Excel.
13. Write procedure to format the text in the cells.
14. Write procedure to enter formulas with built in functions.
15. Write procedure for creating chart in MS-excel.
16. Write Procedure for formatting numbers in MS-Excel.
17. Write procedure for writing criteria and extract the data.
18. Write procedure for printing of a worksheet.
19. Write procedure for formatting of chart in Ms-excel.
20. Write procedure to jump to different workbooks & import worksheet from different workbook.
21. Write procedure to create a database.
22. Write procedure to create a table using design view.
23. Write procedure to create form using forms wizard.
24. Write procedure for creating reports using report wizard.
25. Write procedure for creating a Custom Form.
26. Write the procedure to create custom reports.
27. Write the procedure to print active sheet.
28. Write the procedure for Printing of reports.
29. Draw and explain the groups and commands in create tab under ribbon in MsAccess.
30. Write the procedure for creating Filter by form.

Record book: 10 marks

Viva-voce: 10 marks