

C24_CURRICULUM

**DIPLOMA IN
MECHANICAL ENGINEERING**

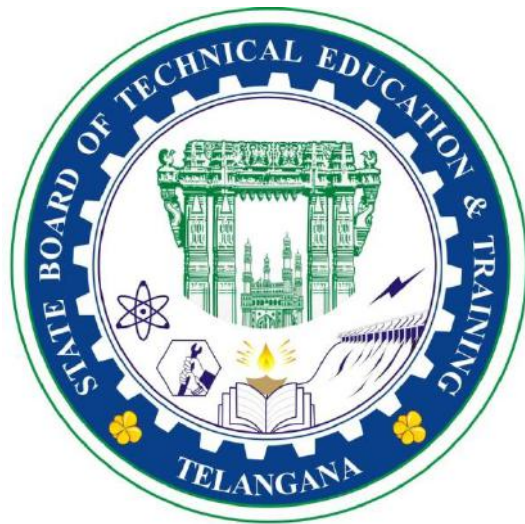

Offered By

**STATE BOARD OF
TECHNICAL EDUCATION AND TRAINING
TELANGANA HYDERABAD**

TEACHING AND EXAMINATION SCHEME

Sl. No.	Course Code	Course Name	Teaching Scheme					Examination Scheme							
			Instruction periods per week			Total Periods per semester	Credits	Continuous internal evaluation			Semester end examination				
			L	T	P			Mid sem. I	Mid sem. II	Internal evaluation	Max. Marks	Min. Marks	Total marks	Min. marks for passing including internal	
1	HU-201	Advanced English	4	1	0	75	2.5	20	20	20	40	14	100	35	
2	SC-202	Engineering Mathematics	4	1	0	75	2.5	20	20	20	40	14	100	35	
3	SC-203	Applied Physics	4	1	0	75	2.5	20	20	20	40	14	100	35	
4	SC-204	Applied Engineering Chemistry	4	1	0	75	2.5	20	20	20	40	14	100	35	
5	CS-205	Programming In C	4	1	0	75	2.5	20	20	20	40	14	100	35	
6	ME-206	Manufacturing Technology	4	1	0	75	2.5	20	20	20	40	20	100	50	
7	ME-207	Engineering Drawing - II	1	0	2	45	1.25	20	20	20	40	20	100	50	
8	ME-208	CAD Lab	1	0	2	45	1.25	20	20	20	40	20	100	50	
9	SC-209	Applied Science Lab	1	0	2	45	1.25	20	20	20	40	20	100	50	
10	CS-210	Programming In C Lab	1	0	2	45	1.25	20	20	20	40	20	100	50	
Total			28	6	8	630	20	200	200	200	400	170	1000	425	

HU - 201: ADVANCED ENGLISH

Course Title	Advanced English	Course Code	HU-201
Semester	II	Course Group	Foundation
Teaching Scheme in Minutes (L:T)	3:2	Credits	2.5
Methodology	Communicative Language Teaching + Assignments	Total Contact Hours	75
CIE	60 Marks	SEE	40 Marks

Prerequisites: Basic knowledge of English Language

COURSE CONTENTS

MODULE 1: VOCABULARY THROUGH READING - II

Duration: 15 Periods (L 9 P 6)

- a. Homonyms, Homophones and Homographs
- b. Root-words and Affixes
- c. Reading – III
Passages on Innovation, Science and Technology, History, Biography, Travel Writing, Nature Writing, Journal, Story, Process, Cause and Effect, Problem Solution, Evaluation of ideas, Reasons and Conclusion, etc.
- d. Reading – IV
Passages on Innovation, Science and Technology, History, Biography, Travel Writing, Nature Writing, Journal, Story, Process, Cause and Effect, Problem Solution, Evaluation of ideas, Reasons and Conclusion, etc.

MODULE 2: SPEAKING- III

Duration: 10 Periods (L 6 P 4)

- a. Making Requests
- b. Offering Help and Suggestions
- c. Expressing Obligations
- d. Seeking and Giving Permissions

MODULE 3: GRAMMAR-III

Duration: 15 Periods (L 9 P 6)

- a. Reported Speech
Conversion from Direct to Indirect Speech but not vice versa
- b. Error Analysis - I
On nouns, articles, pronouns and verbs
- c. Error Analysis - II
Adjectives, adverbs and Prepositions
- d. Error Analysis - III
Questions, concord, redundancy and other kinds of errors

MODULE 4: SPEAKING – IV

Duration: 10 Periods (L 6 P 4)

- a. Giving Directions
- b. Giving Instructions
- c. Talking about the Past
- d. Describing Objects

MODULE 5: WRITING - II

Duration: 15 Periods (L 9 P 6)

- a. Mechanics of Writing
 - i. Spelling, punctuation marks, capitalization and special symbols
 - ii. Different types of fonts, font size, bold, italics, underline, superscript, subscript, alignment, margins, etc.
- b. Data Interpretation -I
 - i. Understand the information and analyze the flow charts and stating the main idea.
 - ii. Describe the process (events or chronological order) interpret flow chart.
 - iii. Use connectives and sequence markers and write a meaningful paragraph.
- c. Data Interpretation -II
 - i. Understand the information in a tree diagram and analyze the data.
 - ii. State the main idea and describe the process from key word.
 - iii. Explain one branch completely and move to the branches down words and write horizontal direction.
 - iv. Use linkers and sequence markers.
- d. Data Interpretation –III
 - i. Understand the data given in tables and pie charts.
 - ii. Analyze and state the main idea of the tables and pie charts.
 - iii. Identify the similarities, differences and mention figures.
 - iv. Use linkers.

MODULE6: WRITING-III

Duration: 10 Periods – (L 6 P 4)

- a. Writing a Resume
 - i. Different formats of a resume
 - ii. Analyze strengths and weaknesses.
- b. Writing a Cover Letter
 - i. Importance of cover letter
 - ii. Format of cover letter
 - iii. Sample cover letter
- c. Note Making
 - i. Understand the Benefits of Note Making.
 - ii. Cue Method
 - iii. Mind Mapping
- d. Writing a Report
 - i. Understand the concept of report writing and formats of various reports.
 - ii. Report on an incident.
 - iii. Report on an industrial visit.
 - iv. Report on events.

COURSE OUTCOMES

CO	At the end of the course the students will be able to
CO 1	Learn vocabulary and use them in professional & social interactions and comprehend the passages.
CO 2	Make requests, offer help and suggestions, express obligations, seek and giving permissions.
CO 3	Learn English grammar to speak and write flawlessly.
CO 4	Give directions and instructions, talk about the past and describe objects.
CO 5	Learn the mechanics of writing to make the technical writing practical and meaningful and interpret the data given.
CO 6	Prepare resumes, prepare cover letters, make notes and draft reports.

CO-PO Matrix

CO	PO 1	PO 2	PO 3	PO 4	PO 5	PO 6	PO 7	Mapping POs
CO 1	-	-	-	-	2	2	2	5, 6 and 7
CO 2	-	-	-	-	2	2	2	5, 6 and 7
CO 3	-	-	-	-	1	3	2	5, 6 and 7
CO 4	-	-	-	-	2	2	3	5, 6 and 7
CO 5	-	-	-	-	1	2	3	5, 6 and 7
CO 6	-	-	-	-	2	2	3	5, 6 and 7

CONTINUOUS INTERNAL EVALUATION (CIE)

Test	Modules	Marks	Pattern
Mid - I	1. Vocabulary Through Reading- II 2. Speaking - III	20	Part A: 4 short answer questions Part B: 2 short essay questions with internal choice Part C: 2 essay questions with internal Choice
Mid - II	1. Grammar - III 2. Speaking - IV	20	Part A: 4 short answer questions Part B: 2 short essay questions with internal choice Part C: 2 essay questions with internal Choice
Slip Test 1	1. Vocabulary Through Reading - II 2. Speaking - III	5	2 questions out of 3 questions
Slip Test 2	1. Grammar - III 2. Speaking - IV	5	2 questions out of 3 questions
Assignment	One assignment per one semester	5	Different group assignments of higher order questions that develop problem solving skills and critical thinking should be given
Seminars	One seminar per one semester	5	Oral presentations using audio –visual equipment, charts, etc.
	Total	60	

Legend:**Remembering: 1 mark Understanding: 3 marks Application: Five marks****Suggested Student Activities:**

- Practice conversation / dialogue / speech and answer the questions.
- Seminars.
- Collect the resumes of the successful people.
- Narrate a story.
- Prepare chain stories.
- Vocabulary building games.
- Speak about incidents / events / memories / dreams / role model.
- Interviews of famous personalities.
- Collect the biographies of unsung heroes.
- Read for main ideas and specific details.
- Picture description.
- Collect the letters written by famous persons and analyze them.
- Describe a process.
- Give directions using maps.
- Collect user manuals and analyze the sets of instructions given.
- Collect the various types of reports and analyze the information.
- Collect the official information given in the forms of tables, tree diagrams and pie charts.

REFERENCES:

1. High School English Grammar & Composition by Wren & Martin
2. Practical English Grammar by A.J Thomson and A.V. Martinet
3. A Course in Phonetics and Spoken English by J. Sethi and P.V Dhamija
4. Word Power Made Easy by Norman Lewis.
5. Essential English Grammar by Raymond Murphy.
6. Spoken English-A Self Learning Guide to Conversation Practice by V. Sasi Kumar.

BOARD DIPLOMA EXAMINATION (C-24)
MID SEMESTER EXAMINATION -I
HU-201 ADVANCED ENGLISH

Time: One Hour

Total Marks: 20

PART - A

1 X 4 = 4 Marks

Instructions: a) Answer all the questions. b) Each question carries one mark.

1. Write the antonym of words using the root word, 'Micro'.
2. Read the following paragraph and answer the question that follows.

Nature is the best gift of God to all living beings on earth. Human beings depend on nature to survive, whereas trees and other living beings balance eco system in nature. Trees, flowers, animals, mountains, rivers, oceans, valleys, sky, forest etc., are parts of nature. Nature provides us air, water, food, light, health and many more to live. But man is misusing all these natural resources for his greediness.

- a) What does nature provide us?
3. How do you request your teacher to repeat the lesson? Write in a sentence.
4. A pregnant lady is boarding a bus with heavy luggage. How do you offer her help?

PART – B

2 X 3 = 6 Marks

Instructions: a) Answer the following questions. b) Each question carries three marks.

5. i) Use the following homonyms in your own sentences.
 - a. Right
 - b. Ring
 - c. Rise

(OR)

- ii) Form antonyms for the given words using suitable prefixes.
 - a) Loyal
 - b) Legal
 - c) Necessary
6. a) Using the words of obligation, write any three precautions you have to take when a little baby is in your home.

(OR)

- b) How do you seek permission from your teacher for attending a training programme? Write your discussion in the form of a dialogue.

PART – C

2 X 5 = 10 Marks

Instructions: a) Answer the following questions. b) Each question carries five marks.

7. a) Read the following passage and answer the questions given below it.

Man used to fly in hot air balloons before the airplane was invented. The first hot air balloon was invented in 1780. Hot air, being lighter than the cold air, made the balloon rise. The first hot air balloon was designed by the Montgolfier Brothers. It took flight in 1783. Hydrogen is the lightest of all gases. It is lighter than air. So it gives a greater lift to the balloon than hot air. Thus, the hydrogen balloon was an improvement on the hot air balloon. Ballooning was a popular sport until the 1930s. Today balloons are used for forecasting the weather and in scientific research most balloons contain Helium which is heavier than Hydrogen but does not burn as easily as Hydrogen.

- i. Who designed the hot air balloon?
- ii. When was the hot air balloon invented?
- iii. Why is hydrogen used in balloons?
- iv. How are the balloons used for today?
- v. What is the meaning of the word, forecast?

(OR)

b). Read the following passage and answer the questions given below it.

Malaria is one of the deadliest and most destructive of all diseases. Thousands of people die of it every year in India alone. In the middle ages, people realized that it was common in places where there was stagnant water or the places such as marshes and swamps. They thought the air was the cause of this disease and named it 'malaria' which means bad air. Not till nearly the end of the nineteenth century, the great discovery was made that it was not the stagnant water nor was it the marshy air which spread malaria. The real culprit was the mosquito.

- i. Name the disease considered to be deadly and destructive?
- ii. What is the meaning of malaria according to people of middle ages?
- iii. Where was malaria very common?
- iv. Nearly how many people die of malaria in India every year?
- v. Name the insect responsible for causing malaria?

8. a) How do you request your friend to clarify your doubts in mathematics. Write a dialogue.

(OR)

b) Your younger brother wants to apply for POLYCET. Give him any five suitable suggestions.

BOARD DIPLOMA EXAMINATION (C-24)
MID SEMESTER EXAMINATION -II
HU-201 ADVANCED ENGLISH

Time: One Hour

Total Marks: 20

PART - A

1 X 4 = 4 Marks

Instructions: a) Answer all the questions. b) Each question carries one mark.

1. She said, 'I am hungry'. (Change the sentence into reported speech)
2. Vijay along with friends go to temple. (Correct the sentence)
3. Give directions to your sister from your home to reach library in your town.
4. Describe your mobile using four adjectives.

PART-B

2 x 3 = 6 Marks

Instructions: a) Answer all the questions. b) Each question carries three marks.

5. a) Change the following into indirect speech.
 - i. She said to him, "Where are you going?"
 - ii. He said to her, "I bought books yesterday."
 - iii. Sunil said to me, "Will you bring your camera tomorrow?"(OR)

b) Correct the following sentences.

- i. They discussed about politics.
- ii. We buy a car two days ago.
- iii. She is my older sister.

6. a) How did you celebrate your birthday recently?
(OR)

b) Describe your laptop or desktop computer in 50 words.

PART-C

2 X5 = 10 Marks

Instructions: a) Answer all the questions. b) Each question carries five marks.

7. a) Change the following sentences into reported speech.

- i. She said, "I saw a cute dog in the park."
- ii. He said, "I am going out."
- iii. Vijay said, "It may rain now."
- iv. Chandu said, "We will go to school tomorrow."
- v. Madhuri said to Prasad, "When did you come?"

(Or)

b) Correct the following sentences.

- i) My birth day is on January.
- ii) You must and should come here.
- iii) This is the horse who won the race.
- iv) I prefer coffee than tea.
- v) I am having a car.

8. a) Write instructions for taking a bus pass.

(Or)

b) Give suggestions to your friend on how to score good marks in POLYCET

BOARD DIPLOMA END EXAMINATION (C-24)

SEMESTER END EXAMINATION

HU-201 ADVANCED ENGLISH

Time: Two Hours

Total Marks: 40

PART-A

1 X 8 = 8 Marks

Instructions: a) Answer all the questions. b) Each question carries one mark.

1. Write the antonyms of the following words using the suitable prefixes.
a) logical b) polite
2. Correct the following sentence.
a) This is the best of the two books I have.
3. What salutations do you use in a cover letter?
4. Rewrite the following sentence using appropriate punctuation marks and capital letters.
a) she told him that she had returned bhaskars book yesterday
5. Correct the spellings of the following words.
a) shedule b) plander
6. Rewrite the following sentence using the appropriate punctuation marks and capital letters.
vinod went to hyderabad on 2nd march 2024.
7. You are applying for the post of Assistant Engineer in BHEL. Write the educational qualifications in the resume.
8. What complimentary closure do you use in a cover letter?

PART-B

3 X 4 = 12 Marks

Instructions: a) Answer all the questions. b) Each question carries three marks.

9. a) Add affixes to the following words.
i) Value
ii) Create
iii) Sense

(OR)

- b) Write a short paragraph on the following Pie chart.

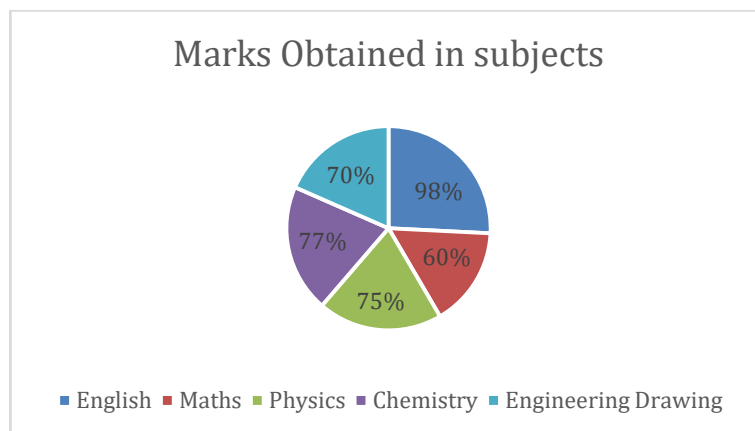

10.a) Write about your favourite past incident.

(OR)

b) Write your three strengths and three limitations.

11.a) Read the following sentence and provide proper punctuation marks.

i) drajay studied his mbbs in gandhi medical college

(OR)

b) Write a paragraph interpreting the data given in the following table.

Year	Salary	Expenditure on housing and transport	Interests on Loan	Savings
2018	70k	30k	7k	33k
2019	75k	35k	10k	30k
2020	80k	40k	13k	37k
2021	90k	45k	13k	37k
2022	1L	50k	14k	46k
2023	1.5L	52k	14k	86k

12. a) V. Vijay completed his M.Tech. He wants to apply for the post of Executive Engineer in Pragathi Engineering Company. Prepare a resume for the same.

(OR)

b) Read the following paragraph and make notes.

Yuvraj Singh is one of the most phenomenal cricketers who have redefined winning over struggle. Since the year 2000, this Punjab boy is the reason for many victories of India. His personal life and his struggle with the dreaded disease cancer is an inspiration for all of us. He is also one of the players who is honored with Arjuna award and has been declared Man of the Tournament in the 2011 ICC Cricket World Cup. Yuvraj Singh made a comeback to India national cricket team (ODI squad) after a lengthy period earlier this year, and fared average. The cricketer, also known for entrepreneurial initiatives and his charity work, says cricket will always be a priority in his life but he also tries to inspire young people with his story. He made India proud by hitting six sixes off an over in 2007, and was part of the Indian cricket team when they won World Cup 2011. But the turning point came in his life when he battled cancer in 2012. Yuvraj found a new meaning to life after the hardship. "Earlier on in my career, it was more about cricket and now it is being more about inspiring people to come out of the adversity and create examples... Since my treatment, things have changed a lot for me."

PART-C

4X 5 = 20 Marks

Instructions: a) Answer all the questions. b) Each question carries five marks. .

13. a) Read the following paragraph and answer the questions:

Once, there lived two friends in a village. Their names were Bhaskar and Suresh. One day they set out on a journey and had to pass through a forest. As they were passing through the forest they saw a big bear coming towards them. They were frightened. Bhaskar at once climbed up a nearby tree to save his life. Suresh did not know how to climb up a tree. But he was wise and intelligent. He had heard that bears do not touch the dead. So he lay on the ground, held his breath and appeared to be dead. The bear came near him sniffed him, thinking him to be dead, it went away. When the bear had left Bhaskar came down from the tree and asked Suresh what the bear had whispered in his ear. Suresh said that the bear had advised him to beware of false friends.

1. Where were the friends going one day?
2. What is the antonym of the word, wise?
3. What did Bhaskar do when bear came towards them?
4. How can you say Suresh was wise and intelligent?
5. Did the Bear really whisper in Suresh's ear?

(OR)

b) Write a paragraph interpreting analyzing the information given in the following table.

Table Showing the Number of Students Admitted in Different Branches in Private Engineering Colleges in the Past Four Years.

Year	ECE	EEE	Mechanical	Civil	CSE
2023	54065	36255	21600	34000	13436
2022	49008	36255	20900	29000	22687
2021	45032	36255	20600	14500	32008
2020	38060	36254	20300	14500	38065

14.a) Change the following into indirect speech.

- i. He said, "I have eaten a banana."
- ii. She said, "I will go to Chennai tomorrow."
- iii. Hari said, "I can speak French."
- iv. Karunakar said to Vani, "I have completed my homework."
- v. Doctor said to Mani, "Are you a Professor?"

(OR)

b)
industry you visited recently.

Write a report on the

15. a) Rewrite the following sentences using proper punctuation marks and capital letters.

- i. when you are coming.
- ii. i love Flowers?
- iii. this is my cousins book.
- iv. "all that glittersis not gold.
- v. What a melodious song?

b)Observe the following flow chart and write a paragraph describing the steps involved in creating an e-mail.



16. a) Write a cover letter applying for the post of Work Supervisor at Bharath Electronics Private Limited.

(OR)

b) Write a report to the Principal on how you have conducted the Seminar on Robotics.

SC-202 : ENGINEERING MATHEMATICS

Course Title	Engineering Mathematics	Course Code	SC-202
Semester	II	Course Group	Foundation
Teaching Scheme in Periods (L : T : P)	4:1:0	Credits	2.5
Methodology	Lecture + Tutorial	Total Contact Periods	75
CIE	60 Marks	SEE	40 Marks

Pre requisites:

This course requires the basic knowledge of Algebra, Trigonometry in Mathematics at Secondary school level and Basic Engineering Mathematics at Diploma 1st Semester level

Course Outcomes (COs):

At the end of the course, the student will have the ability to:

CO 1	Solve simple problems in straight lines and circle using various formulae
CO 2	Solve the simple problems in conic section by using its properties
CO 3	Evaluate the Limits of Algebraic, Rational and Trigonometric functions.
CO 4	Determine the Derivatives of various Functions
CO 5	Determine the Derivatives of various functions by using various Differentiation Methods
CO 6	Solve some problems in Geometrical applications of derivatives and Maxima and Minima

Course Contents:

Unit – I Straight lines and Circles: Duration: 12 Periods (L: 10– T:2)

Straight lines: Slope of straightline - Various forms of straightline-Horizontal and Vertical lines, Point-Slope form, Two-Point form, Slope-Intercept form, Intercept form, Normal form and General equation of a Straight line- Angle between two Straight lines- Conditions for Parallelism and Perpendicularity of the Straight lines –Equations of parallel and Perpendicular Straight lines- Distance of a point from a line -Distance between two Parallel lines - Intersection of two non-parallel lines - Related problems.

Circles: Definition of Locus of a point and Circle and its equation - Equation of the Circle, given (i) Centre and Radius, (ii) Two ends of a Diameter (iii) Centre and a point on the Circumference (iv) Centre and Tangent and (v) Three non-collinear points - Related problems.

Unit – II Conic Sections:**Duration: 13 Periods (L: 10 – T:3)**

Definitions of Conic Section, Focus, Eccentricity, Directrix, Axes and Latus rectum - **Parabola:** Standard equations of Parabolas have focus on one of the coordinate axes; vertex at origin and directrix is parallel to the other coordinate axis - **Ellipse:** Standard equations of Ellipses have centre at the origin and the major and minor axes are coordinate axes - **Hyperbola:** Standard equations of Hyperbola have centre at the origin and the transverse and conjugate axes are coordinate axes - Related properties and problems.

Unit-III Functions & Limits:**Duration: 12 Periods (L: 10– T: 2)**

Definition of a function - Constants and Variables - Independent and Dependent Variables - Various types of functions: Constant function, Explicit and Implicit functions, Even and Odd functions, Hyperbolic functions, Modulus function and Function of a function with examples - Intervals and Neighbourhoods - Meaning of $x \rightarrow a$ - Definition of Limit of a function - Properties of Limits - Indeterminate forms- Standard Limits (without proof)- Evaluation of Limits of the form: $\lim_{x \rightarrow \infty} \frac{f(x)}{g(x)}$ using Algebraic techniques- Evaluation of limits of the form: $\lim_{x \rightarrow l} \frac{f(x)}{g(x)}$ using Direct Substitution, Factorization, Rationalization and Reduction to Standard forms.

Unit – IV Differential Calculus – I:**Duration: 13 Periods (L: 10 – T:3)**

Definition of Derivative of a function (First Principle of Derivatives) - Different notations - Derivatives of Standard Algebraic, Logarithmic, Exponential, Trigonometric, Hyperbolic and Inverse Trigonometric functions - Algebra of derivative of functions: Derivatives of Sum, Difference, Scalar Multiplication, Product, Quotient of functions - Derivative of function of a function (Chain rule) - Related problems.

Unit – V Differential Calculus – II:**Duration: 13 Periods (L: 10 – T: 3)**

Logarithmic Differentiation - Derivative of Implicit functions - Differentiation of an Infinite Series - Derivative of Parametric functions - Differentiation of a function with respect to another function - Successive differentiation with emphasis on second order - Functions of several variables - Partial Differentiation - Euler's theorem for Homogeneous functions - Related problems.

Unit – VI Applications of Derivatives:**Duration: 12 Periods (L: 10– T: 2)**

Geometrical Applications: Geometrical meaning of the Derivative - Slope of Tangent, Slope of Normal, Equations of Tangent and Normal to the curve at any point on the curve - Lengths of Tangent, Normal, Sub-tangent and Sub-normal to the curve at a point on the curve - Angle between two intersecting curves - Related problems.

Maxima & Minima:Increasing and decreasing functions - Extreme values and Extreme points - Conditions for Maxima and Minima of function of single variable -The maxima and minima of simple functions - Problems leading to engineering applications.

Reference Books:

1. The Elements of Co - Ordinate Geometry – by S.L. Loney.
2. Thomas Calculus, Pearson Publications.
3. NCERT Mathematics Text Books of ClassXI,XII.
4. Intermediate Mathematics Text Book IB (Telugu Academy).
5. Differential Calculus -by Shanti Narayan and P. K. Mittal.

Suggested E-Learning references:

1. <https://www.khanacademy.org/>
2. <https://www.desmos.com/>
3. <https://www.wolframalpha.com/>
4. <http://tutorial.math.lamar.edu/>

Suggested Learning Outcomes:

At the end of the course, the student will have the ability to:

1.0 Formulate the equations of Straight lines and Circles in different forms and usingthese in solving practical problems.

- 1.1 Define slope of a straight line.
- 1.2 Classifyvarious forms of a straight line:
 - (i) Horizontal and Vertical lines,
 - (ii) Point-slope form,
 - (iii) Two-point form,
 - (iv) Slope-intercept form,
 - (v) Intercept form,
 - (vi) Normal form and
 - (vii) General equation of a straight line.
- 1.3 Solve the problems on 1.2.
- 1.4 Find the acute angle between two straight lines.
- 1.5 Explain the conditions for parallelism and perpendicularity of straightlines.
- 1.6 Find the equation of parallel line which is passing through the given point.
- 1.7 Find the equation of perpendicular line which is passing through the given point.
- 1.8 Calculate the distance of a point from a line.
- 1.9 Evaluate the distance between two parallel lines.

- 1.10 Determine the point of intersection of two non-parallel lines.
- 1.11 Define locus of a point and circle.
- 1.12 Write the general equation of a circle with centre and radius.
- 1.13 Find the equation of a circle having its centre and radius.
- 1.14 Find the equation of a circle having two ends of a diameter.
- 1.15 Find the equation of a circle having its centre and a point on the circumference.
- 1.16 Find the equation of a circle having its centre and tangent.
- 1.17 Find the equation of a circle passing through three non-collinear points.
- 1.18 Solve the related problems from 1.12 to 1.17.

2.0 Identify the Conic sections, Describe the properties of Parabola, Ellipse and Hyperbola, and solve the engineering problems involving them.

- 2.1 Define conic section.
- 2.2 Explain the terms focus, eccentricity, directrix, axes and latus-rectum of the conic.
- 2.3 Describe the properties of parabola in standard forms have focus on one of the coordinate axes; vertex at origin and directrix is parallel to the other coordinate axis.
- 2.4 Describe the properties of ellipses in standard forms have centre at the origin and the major and minor axes are coordinate axes.
- 2.5 Describe the properties of hyperbolas in standard forms have centre at the origin and the transverse and conjugate axes are coordinate axes.
- 2.6 Solve the problems related to 2.3, 2.4 and 2.5

3.0 Evaluate the Limits of Algebraic, Rational and Trigonometric functions.

- 3.1 Define function with example.
- 3.2. Explain constants, variables, independent and dependent variables.
- 3.3 Define various types of functions:
 - (i) Constant function,
 - (ii) Explicit and Implicit functions,
 - (iii) Even and Odd functions,
 - (iv) Hyperbolic functions,
 - (v) Modulus function and
 - (vi) Function of a function with examples.
- 3.4 Explain intervals and neighbourhoods.
- 3.5 Explain the meaning of $x \rightarrow a$.
- 3.6 Define Limit of a function.
- 3.7 Explain the Properties of Limits.
- 3.8 State indeterminate forms.

3.9 State the standard limits: $\lim_{x \rightarrow a} \frac{x^n - a^n}{x - a}$, $\lim_{x \rightarrow 0} \frac{\sin x}{x}$, $\lim_{x \rightarrow 0} \frac{\tan x}{x}$, $\lim_{x \rightarrow 0} \frac{a^x - 1}{x}$, $\lim_{x \rightarrow 0} \frac{e^x - 1}{x}$,

$$\lim_{x \rightarrow 0} (1+x)^{\frac{1}{x}}, \quad \lim_{x \rightarrow \infty} \left(1 + \frac{1}{x}\right)^x.$$

3.10 Evaluate the Limits of the form $\lim_{x \rightarrow \infty} \frac{f(x)}{g(x)}$ using Algebraic techniques.

3.11 Evaluate limits of the form $\lim_{x \rightarrow l} \frac{f(x)}{g(x)}$ using

- (i) Direct substitution,
- (ii) Factorization,
- (iii) Rationalization and
- (iv) Reduction to standard forms.

4.0 Appreciate Differentiation and its meaning in engineering situations

4.1 Define the concept of derivative of a function $y = f(x)$ as $\lim_{h \rightarrow 0} \frac{f(x+h) - f(x)}{h}$ (First Principle of Derivatives) and also provide standard notations to denote the derivative of a function.

4.2 Find the derivatives of simple elementary functions like k (constant), x^n , \sqrt{x} , $\sin x$, $\cos x$ using the First Principle of Derivatives.

4.3 List the formulae for derivatives of standard algebraic, logarithmic, exponential, trigonometric, hyperbolic and inverse trigonometric functions.

4.4 Use the Algebra of derivatives of functions, i.e. derivative of sum, difference, scalar multiplication, product and quotient of functions to solve problems.

4.5 Find the derivatives using the method of Differentiation of a Function of a function (Chain rule).

5.0 Determine the Derivatives of various functions by using various Differentiation Methods

5.1 Apply the Properties of Logarithms for differentiating functions of the form: $[f(x)]^{g(x)}$.

5.2 Explain the procedure for finding derivatives of Implicit functions with examples.

5.3 Find the derivatives of Infinite series of the form: (i) $\sqrt{f(x) + \sqrt{f(x) + \sqrt{f(x)} \dots \infty}}$ and

(ii) $f(x)^{f(x)^{f(x) \dots \infty}}$.

5.4 Explain the method of Parametric Differentiation with examples.

5.5 Explain the method of Differentiation of a function with respect to another function with examples.

5.6 Explain successive differentiation with examples and solve engineering problems related to second order.

5.7 Define functions of several variables and explain partial derivatives up to second order with examples.

- 5.8 Define homogeneous functions with examples.
- 5.9 State Euler's theorem for homogeneous functions.
- 5.10 Verify Euler's theorem for homogeneous functions.
- 5.11 Apply Euler's theorem to solve engineering problems involving partial derivatives.

6.0 Understand the Geometrical Applications of derivatives and Maxima and Minima of a functions

- 6.1 State the geometrical meaning of the derivative of a function as the slope of the tangent to the curve $y=f(x)$ at any point on the curve.
- 6.2 Use the concept of derivative to find the slope of normal at a point on the curve.
- 6.3 Determine the equations of tangent and normal to the curve $y=f(x)$ at any point on the curve.
- 6.4 Calculate the lengths of tangent, normal, sub-tangent and sub-normal at any point on the curve $y=f(x)$.
- 6.5 Apply the concept of derivatives for finding the angle between two intersecting curves with illustrative examples.
- 6.6 Define increasing and decreasing functions.
- 6.7 State the conditions for increasing and decreasing functions.
- 6.8 Use the conditions 6.7 to find points where the given function is increasing or decreasing.
- 6.9 Define Extreme Values (Maximum and minimum values) and Extreme points (Points of Maximum and minimum) of a function of single variable.
- 6.10 Explain conditions for maxima and minima.
- 6.11 Find the Maxima and minima of simple functions.
- 6.12 Apply maxima and minima to solve engineering problems.

Suggested Student Activities:

1. Student visits Library to refer Standard Books on Mathematics and collect related material.
2. Quiz.
3. Group discussion.
4. Group Tests.
5. Formulae Tests.
6. Surprise tests.
7. Seminars.
8. Home assignments.
9. Mathematics for preparing competitive exams. Solving old question papers on arithmetical ability.

CO / PO - MAPPING

CO	PO1	PO2	PO3	PO4	PO5	PO6	PO7	Mapped POs
CO1	3	1					3	1,2,7
CO2	3	2					3	1,2,7
CO3	3	2	1				3	1,2,3,7
CO4	3	2	1				3	1,2,3,7
CO5	3	2	1				3	1,2,3,7
CO6	3	2	3				3	1,2,3,7

**STATE BOARD OF TECHNICAL EDUCATION & TRAINING, TELANGANA
DIPLOMA EXAMINATIONS (C - 24)**

SC-202

**SEMESTER II, MID – I EXAM, MODEL PAPER
ENGINEERING MATHEMATICS**

Duration: 1: 00 Hour

Max. Marks: 20

PART-A

Instructions: 1. Answer **ALL** questions. 04 × 01 = 04
2 Each question carries **ONE** mark.

1. Write the normal form of a straight line.
2. Find the equation of the point circle whose centre is (1,2).
3. Write the standard form of an ellipse whose major axis is x - axis.
4. Find the equation of directrix of the parabola $y^2 = 36x$.

PART-B

Instructions: 1. Answer any **TWO** questions. 02 × 03 = 06
2. Each question carries **THREE** marks.

- 5(a) If the equation of a line is $3x - 4y + 10 = 0$, then find i) its slope ii) x & y intercepts.

OR

- 5(b) Find the equation of the circle passing through the points (2,3) and touches the line $x - 3y - 11 = 0$.

- 6(a) Find the equation of the parabola whose focus is (5, 0) and directrix is $x + 5 = 0$.

OR

- 6(b) Find the equation of an ellipse whose end points of major axis are $(\pm 3, 0)$ and end points of minor axis are $(0, \pm 2)$.

PART C

Instructions: 1. Answer any **FOUR** questions. 02 × 05 = 10
2. Each question carries **FIVE** marks.

- 7(a) Find the angle between straight lines $x + 3y - 1 = 0$ and $2x + 5y - 2 = 0$.

OR

- 7(b) Find the equation of the circle passing through the points (0, 0), (2, 0) and (0, 3).

- 8(a) Find the coordinates of foci, eccentricity and the length of latus rectum, equations of latera-recta and directrices of the ellipse $49y^2 - 16x^2 = 784$.

OR

- 8(b) Find the equation of the hyperbola whose centre is at (0,0) and passes the points (3,2) and (1,6).

STATE BOARD OF TECHNICAL EDUCATION & TRAINING, TELANGANA
DIPLOMA EXAMINATIONS (C - 24)
SC-202
SEMESTER II, MID – II EXAM, MODEL PAPER
ENGINEERING MATHEMATICS

Duration: 1: 00 Hour

Max. Marks: 20

PART-A

Instructions: 1. Answer **ALL** questions. 04 × 01 = 04
2 Each question carries **ONE** mark.

1. Find $\lim_{x \rightarrow 3} \left(\frac{x^3 - 3x^2}{x^2 - 5x + 6} \right)$.
2. Find $\lim_{\theta \rightarrow 0} \left(\frac{\sin 2\theta}{\theta} \right)$.
3. Differentiate $\tan(3x - 7)$ with respect to x .
4. If $y = x \cdot e^x$, then find $\frac{dy}{dx}$.

PART-B

Instructions: 1. Answer any **TWO** questions. 02 × 03 = 06
2. Each question carries **THREE** marks.

5(a) Evaluate: $\lim_{x \rightarrow 5} \left(\frac{x^3 - 125}{x - 5} \right)$.

OR

5(b) Evaluate: $\lim_{x \rightarrow \infty} \left(1 + \frac{5}{x} \right)^x$.

6(a) Find the derivative of $\left(\frac{2x+3}{4x+5} \right)$ with respect to x .

OR

6(b) Differentiate $\sin^{-1}(3x - 4x^3)$ with respect to x .

PART C

Instructions: 1. Answer any **FOUR** questions. 02 × 05 = 10
2. Each question carries **FIVE** marks.

7(a) Evaluate: $\lim_{n \rightarrow \infty} \frac{1^2 + 2^2 + 3^2 + \dots + n^2}{n^3}$.

OR

7(b) Evaluate: $\lim_{\theta \rightarrow 0} \left(\frac{\cos 3\theta - \cos 5\theta}{\cos 7\theta - \cos 9\theta} \right)$.

8(a) If $y = \sqrt{e^x + \log(\log(\sin x))}$ then find $\frac{dy}{dx}$.

OR

8(b) Find the derivative of $\sin x$ with respect to x by using first principle of derivatives.

STATE BOARD OF TECHNICAL EDUCATION & TRAINING, TELANGANA
DIPLOMA EXAMINATIONS (C - 24)
SC-202
SEMESTER II, END SEMESTER EXAM, MODEL PAPER
ENGINEERING MATHEMATICS

Duration: 2:00 Hours

Max. Marks: 40

PART-A

Instructions: 1. Answer **ALL** questions.

08 × 01 = 08

2 Each question carries **ONE** mark.

1. Find the slope of a straight line passing through the points $(-2, 3)$ and $(4, 8)$.
2. Find $\lim_{x \rightarrow 0} \frac{x^2 + 3x + 2}{x^2 + 4x + 3}$.
3. Find the second order derivative of $x^3 + 4x^2 + 2$ with respect to x .
4. Write the equation of a parabola whose focus is $(a, 0)$ and the directrix is $x = -a$.
5. If $u(x, y) = x^2y$, then find $\frac{\partial y}{\partial x}$.
6. Find $(\frac{dy}{dx})$ if $xy = 2025$.
7. Find the slope of the curve $y = x^2 + 5x - 2025$ at $(1, 2)$.
8. Write the conditions for a point to be a minimum point on the curve $y = f(x)$.

PART-B

Instructions: 1. Answer any **FOUR** questions.

04 × 03 = 12

2. Each question carries **THREE** marks.

9(a) If $(1, 3)$ is an extremity of a diameter of the circle $3x^2 + 3y^2 + 6x - 12y - 2 = 0$, then find the other end point of the diameter.

OR

9(b) If $y = x^x$, then find $\frac{dy}{dx}$.

10(a) Evaluate: $\lim_{x \rightarrow 0} \frac{1 - \cos x}{x^2}$.

OR

10 (b) Find the equation of tangent to the curve $y^2 = 8x$, at $(2, 4)$.

11(a) Find $\frac{dy}{dx}$, if $x = \lambda t$ and $y = \frac{\lambda}{t}$.

OR

11(b) If $u = \tan^{-1} \left(\frac{y}{x} \right)$, then prove that $\frac{\partial^2 u}{\partial x^2} + \frac{\partial^2 u}{\partial y^2} = 0$.

12(a) The sum of two numbers is 20. Find the numbers such that the sum of their squares is minimum.

OR

12 (b) Find the angle between the curves $y = x^2$ and $x^2 = y$.

PART C

Instructions: 1. Answer any **FOUR** questions

04 × 05 = 20

2. Each question carries **FIVE** marks

13(a) Find the centre, foci, vertices, eccentricity, length of latus-rectum and lengths of major and minor axes of the ellipse $\frac{x^2}{25} + \frac{y^2}{16} = 1$

OR

13 (b) Find $\frac{dy}{dx}$, if $\sqrt{x} + \sqrt{y} = \sqrt{a}$

14 (a) Differentiate $\log(x + \sqrt{x^2 + 1})$ with respect to x .

OR

14 (b) Show that $y^2 = 4(x + 1)$ and $y^2 = 36(9 - x)$ cut each other orthogonally.

15(a). If $y = (\sin x)^{(\sin x)^{(\sin x)^{\dots\infty}}}$, then find $\frac{dy}{dx}$.

OR

15 (b) Find the derivative of $\log \tan 2x$ with respect to $\cot 2x$

16 (a). A right circular cylinder is inscribed in a sphere of radius R , show that the volume is maximum when its height is $\frac{2R}{3}$.

OR

16 (b) Find the lengths of tangent, normal, sub-tangents and sub-normal for the curve

$$2x^2 + 3xy - 2y^2 - 8 = 0 \text{ at } (2, 3).$$

SC-203 : APPLIED PHYSICS

Course Title:	Applied Physics	Course Code :	SC-203
Semester:	II Semester	Course Group :	Foundation
Teaching Scheme in Periods(L:T:P):	4:1:0	Credits :	2.5
Type of Course :	Lecture+ Tutorials	Total Contact Periods :	75 Periods
CIE :	60 Marks	SEE :	40 Marks

Pre requisites

This course requires the basic knowledge of Science and Mathematics

Course Outcomes

Upon completion of the course, the student shall be able to

CO1	Explain the motion characteristics displacement, velocity, acceleration of Simple Harmonic Motion and apply the formulation to obtain time period of simple pendulum.
CO2	Classify wave motions and apply mathematical formulations to echo, Doppler effect and identify causes, effects and minimizing method of noise pollution.
CO3	Explain basic concepts of electricity and extend Kirchhoff's laws to construct Meter bridge to determine unknown resistance.
CO4	Identify magnetic materials and apply laws of electromagnetic induction to construct transformer.
CO5	Utilize the laws and principles of Photoelectric effect, LASER and optical fibers to build Photocell and Ruby LASER.
CO6	Apply the properties of semiconductors and volt-ampere characteristics of P-N junction diode to construct half wave and full wave rectifiers and Light Emitting Diode.

	Basic and Discipline Specific Knowledge	Problem Analysis	Design/Development of Solutions	Engineering Tools, Experimentation and Testing	Engineering Practices for Society, Sustainability and Environment	Project Management	Lifelong Learning	Linked PO
CO	PO1	PO2	PO3	PO4	PO5	PO6	PO 7	
CO1	3	-	-		-	-	2	1,7
CO2	3	-	-	1	-	-	2	1,4,7
CO3	3	1	-	1	-	-	2	1,2,4,7
CO4	3	1	-	1	-	-	2	1,2,4,7
CO5	3		-	1	-	-	2	1,4,7
CO6	3		-	1	1	-	2	1,4,5,7

Course content:

Unit 1 Simple Harmonic Motion

Duration: 12 periods (L:10 – T:2)

Periodic motion and Simple Harmonic Motion (SHM) – examples of SHM, conditions of SHM, time period, frequency, amplitude and phase of a particle in SHM-definitions, expressions for Displacement, Velocity, Acceleration, Time period and Frequency of a particle executing in SHM – derivations- numerical problems, Ideal simple pendulum-definition, expression for time period of simple pendulum-derivation- numerical problems, laws of simple pendulum, second's pendulum-length of second's pendulum.

Unit 2 Waves and Acoustics

Duration: 13 periods (L:10 – T:3)

Wave-definition-characteristics, longitudinal and transverse waves –explanation- examples –Audible range, infrasonic and ultrasonic waves, expression relating wave velocity, frequency and wavelength-derivation- numerical problems, , phenomenon of beats - applications - numerical problems, echo – explanation- time of echo from a distant obstacle-derivation- numerical problems-applications of echo, Doppler Effect in sound-formula for Doppler shift- numerical problems, applications of Doppler Effect, SONAR,Reverberation, reverberation time and Sabine's formula, acoustics of good auditorium, free and forced vibrations, and resonance – definition-examples, noise pollution- causes, effects and methods to minimize noise pollution.

Unit 3 Electricity

Duration: 12 periods (L:10 – T:2)

Electric current and potential difference-summarize, Ohm's law-explanation-numerical problems, specific resistance-explanation-numerical problems, conductivity and conductance-definitions, combination of resistors in electric circuit –formula for series and parallel combination-related numerical problems, Heating effect of electric current –applications- heat produced and electric power consumed in a current carrying wire -derivations, electric power- numerical problems, Kirchhoff's laws in electricity –explanation- numerical problems, Wheatstone's bridge –explanation, condition for balancing of Wheatstone's bridge –derivation-numerical problems, Meter Bridge-explanation-numerical problems.

Unit 4 Electromagnetism

Duration: 13 periods (L:10 – T:3)

Magnetic pole, pole strength, magnetic length of a bar magnet. Magnetic field, magnetic lines of force and magnetic induction, properties of magnetic lines of force, uniform and non uniform magnetic fields, magnetic flux, magnetization, magnetic intensity, magnetic permeability and magnetic susceptibility- simple numerical problems, types of magnetic materials.

Coulomb's inverse square law of magnetism-explanation-numerical problems, expression for moment of couple on a bar magnet placed in a uniform magnetic field- derivation- numerical problems, expression for magnetic induction field strength at a point on the axial line of a bar magnet – derivation- numerical problems, Faraday's laws of electromagnetic induction, Lenz's law-explanation, self induction and mutual induction, construction of transformer-types of transformers-numerical problems.

Unit 5 Modern Physics

Duration: 13 periods (L:10 – T:3)

Electromagnetic spectrum-regions, Photo electric effect-explanation-Einstein's photo electric equation, work function and threshold frequency, laws of photo electric effect, working of photocell, applications of photocell, LASER-definition, concept of energy levels, Spontaneous emission, Stimulated emission, population inversion and optical pumping, characteristics of LASER, Ruby LASER, applications of LASER, critical angle and total internal reflection of light, principle and working of Optical fiber, types of optical fiber (Step index and Graded index), applications of optical fiber, Nanosclae and properties of nanomaterials - applications.

Unit 6 Semiconductor Physics

Duration: 12 periods (L:10 – T:2)

Valence band, Conduction band and Forbidden energy gap in solids-explanation, Conductors, Insulators and Semiconductors on the basis of energy band diagram, Fermi level, Intrinsic semiconductors-explanation-examples, concept of hole and doping in semiconductors, Extrinsic semiconductors-explanation, PN Junction Diode-explanation, Forward bias and Reverse bias of PN diode, Volt-Ampere (V-I) characteristics of PN Diode, applications of PN Diode, half wave rectifier and full wave rectifier, working principle of Light Emitting Diode (LED).

Reference Books

1. Principles of Physics by N. Subrahmanyam and Brijlal, S. Chand & Co, New Delhi, edition, 1982
2. Engineering Physics by R.K. Gaur, S.L. Gupta, Dhanpatrai Publications, New Delhi.
3. Intermediate Physics, Telugu Academy, TS, Hyderabad.
4. Fundamentals of Physics by Halliday and Resnick.
5. Physics Part-I & II, NCERT

E-learning resources:

Hyper Physics website: <http://hyperphysics.phy-astr.gsu.edu/>

Learning Outcome:

Upon completion of this course the student will be able to

Unit 1 Simple Harmonic Motion

- 1.1 Explain periodic motion and Simple Harmonic Motion (SHM).
- 1.2 List the examples of SHM.
- 1.3 List the conditions of Simple Harmonic Motion.
- 1.4 Define the terms time period, frequency, amplitude and phase of a particle in SHM.
- 1.5 Develop the expressions for Displacement, Velocity, Acceleration, Time period and Frequency of a particle executing in SHM and solve numerical problems.
- 1.6 Define Ideal simple pendulum and develop the expression for time period of simple pendulum and solve numerical problems.
- 1.7 Develop the laws of simple pendulum.
- 1.8 Define second's pendulum and determine its length on the Earth.

Unit 2 Waves and Acoustics

- 2.1 Define wave and outline the characteristics of wave (frequency, wavelength, amplitude and time period).
- 2.2 Explain longitudinal and transverse waves with examples and distinguish them.
- 2.3 Explain audible range, infrasonic waves and ultrasonic waves.
- 2.4 Develop the expression relating wave velocity, frequency and wavelength ($v = n\lambda$) and solve numerical problems.
- 2.5 Explain the phenomenon of beats with legible diagram, list the applications of beats and solve numerical problems.
- 2.6 Explain echo and develop the formula for time of echo from a distant obstacle and solve numerical problems.
- 2.7 List the applications of echo.
- 2.8 Explain Doppler Effect in sound (no derivation, formulae only)- (i) source moves toward stationary observer (ii) source moves away from stationary observer (iii) observer moves toward stationary source (iv) observer moves away from stationary source and solve simple numerical problems.
- 2.9 List the applications of Doppler Effect.
- 2.10 Explain SONAR.
- 2.11 Explain Reverberation, reverberation time and outline Sabine's formula.

- 2.12 Identify the requirements for acoustically good auditorium.
- 2.13 Explain free vibrations, forced vibrations and resonance with examples.
- 2.14 Explain noise pollution and identify the causes, effects and methods to minimize noise pollution.

Unit 3 Electricity

- 3.1 Summarize the concept of electric current and potential difference.
- 3.2 Explain Ohm's law and solve numerical problems.
- 3.3 Explain specific resistance ($\rho = \frac{RA}{l}$) and solve related numerical problems.
- 3.4 Define conductivity and conductance.
- 3.5 Explain combination of resistors in electric circuit and develop formulae for equivalent resistance in series and parallel connection and solve related numerical problems.
- 3.6 Explain Heating effect of electric current and list the applications of it. Develop formulae for heat produced ($H = I^2Rt$) and electric power consumed ($P=VI$) in a current carrying wire and solve numerical problems.
- 3.7 Explain Kirchhoff's laws in electricity and solve numerical problems.
- 3.8 Construct Wheatstone bridge and develop balancing condition of it starting from Kirchhoff's laws in electricity and solve numerical problems.
- 3.9 Construct Meter Bridge for determination of unknown resistance and solve numerical problems.

Unit 4 Electromagnetism

- 4.1 Explain magnetic pole, pole strength and magnetic length of a bar magnet.
- 4.2 Explain magnetic field, magnetic lines of force and magnetic induction.
- 4.3 List the properties of magnetic lines of force.
- 4.4 Explain uniform and non uniform magnetic fields.
- 4.5 Define magnetic flux.
- 4.6 Explain magnetization, magnetic intensity, magnetic permeability and magnetic susceptibility and solve simple numerical problems.
- 4.7 Explain types of magnetic materials (dia, para and ferro magnetic materials) based on magnetic properties.
- 4.8 Explain Coulomb's inverse square law of magnetism and solve numerical problems.
- 4.9 Develop expression for moment of couple on a bar magnet placed in a uniform magnetic field ($C = MB \sin\theta$) and solve numerical problems.
- 4.10 Develop expression for magnetic induction field strength at a point on the axial line of a bar magnet [$B = \frac{\mu_0}{4\pi} \frac{2M}{d^3}$] and solve numerical problems for short bar magnet.
- 4.11 Explain Faraday's laws of electromagnetic induction.
- 4.12 Explain Lenz's law.
- 4.13 Explain Self induction and Mutual induction.
- 4.14 Explain construction and working of transformer using the principles of electromagnetic induction with legible diagram.
- 4.15 Construct a transformer to Step up and Step down input voltage with legible sketch.

Unit 5 Modern Physics

- 5.1 Outline the regions of electromagnetic spectrum.
- 5.2 Explain Photo electric effect.
- 5.3 Outline Einstein's photo electric equation; explain work function and threshold frequency and solve numerical problems.
- 5.4 Develop laws of photo electric effect.
- 5.5 Explain construction and working of photocell.
- 5.6 Identify applications of photocell.
- 5.7 Explain LASER and concept of energy levels (Ground state, excited state and Meta stable state).
- 5.8 Explain Spontaneous emission, Stimulated emission, population inversion and optical pumping.
- 5.9 List the characteristics of LASER.
- 5.10 Explain construction and working of Ruby LASER.
- 5.11 Identify applications of LASER.
- 5.12 Explain critical angle and total internal reflection of light.
- 5.13 Make use of optical properties to explain working of Optical fiber.
- 5.14 Construct Step index and Graded index optical fibers.
- 5.15 Identify applications of optical fiber.
- 5.16 Explain Nano scale and identify properties at nano scale.
- 5.17 Classify Nano materials (zero, one, two and three dimensional).
- 5.18 Identify applications of nano materials.

Unit 6 Semiconductor Physics

- 6.1 Outline the concept of Valence band, Conduction band and Forbidden energy gap in solids.
- 6.2 Explain Conductors, Insulators and Semiconductors on the basis of energy band diagram.
- 6.3 Explain the concept of Fermi level.
- 6.4 Explain Intrinsic semiconductors with examples.
- 6.5 Explain the concept of hole and doping in semiconductors.
- 6.6 Explain Extrinsic semiconductors and identify differences between P-type and N-type semiconductors.
- 6.7 Explain PN Junction Diode.
- 6.8 Explain Forward bias and Reverse bias PN junction diode.
- 6.9 Summarize Volt-Ampere (V-I) characteristics of PN Diode.
- 6.10 Identify the applications of PN Diode.
- 6.11 Construct half wave and full wave rectifiers by making use of the characteristics of PN Diode.
- 6.12 Draw a labeled diagram and explain working of Light Emitting Diode (LED).

STATE BOARD OF TECHNICAL EDUCATION & TRAINING, TELANGANA

DIPLOMA EXAMINATION (C 24)

SEMESTER II

MID-I EXAM

SC 203 Applied Physics

Model Question paper

Duration: 1hour

Max.Marks: 20

PART-A

4 X 1 = 4

- Instructions: 1. Answer **ALL** questions.
2. Each question carries **ONE** mark.

1. Define periodic motion.
2. Define second's pendulum.
3. Name one example each for longitudinal and transverse waves.
4. Define reverberation.

PART-B

2 X 3 = 6

- Instructions: 1. Answer **ALL** questions.
2. Each question carries **THREE** marks.

- 5 (a) List the conditions for SHM.

(OR)

- (b) The acceleration of a particle in S.H.M. is 0.09 ms^{-2} when its displacement is 0.25 m. Find the period of oscillation.

- 6 (a) The frequency of sound is 110 Hz and wavelength is 3 m. Calculate the velocity of the wave.

(OR)

- (b) Draw a neat labeled sketch of formation of beats.

PART-C

2 X 5 = 10

- Instructions: 1. Answer **ALL** questions.
2. Each question carries **FIVE** marks.

- 7 (a) Develop the formula for acceleration of a particle executing SHM and analyze for maximum and minimum accelerations.

(OR)

- (b) Develop the expression for time period of a simple pendulum.

- 8 (a) Explain echo and apply principle of echo to find the distance of an obstacle from the observer.

(OR)

- (b) List five methods to minimize noise pollution.

STATE BOARD OF TECHNICAL EDUCATION & TRAINING, TELANGANA
DIPLOMA EXAMINATION (C 24)
SEMESTER II
MID-II EXAM
SC 203 Applied Physics
Model Question paper

Duration: 1hour

Max.Marks: 20

PART-A

$4 \times 1 = 4$

Instructions: 1. Answer **ALL** questions.
2. Each question carries **ONE** mark.

1. Define conductance.
2. What is the principle involved in Meter Bridge?
3. Define magnetic field.
4. Define magnetic permeability.

PART-B

$2 \times 3 = 6$

Instructions: 1. Answer **ALL** questions.
2. Each question carries **THREE** marks.

- 5 (a) An electric fan has a resistance of 100ohms. It is plugged into potential difference of 220 V.
How much current passes through the fan?
(OR)

(b) Explain specific resistance of a conductor.

- 6 (a) Two magnetic poles of strengths 40 A-m and 30 A-m are separated by a distance of 0.2 m in air. Calculate the force between them.
(OR)

(b) Draw labeled diagrams of step up and step down transformers and identify various components.

PART-C

$2 \times 5 = 10$

Instructions: 1. Answer **ALL** questions.
2. Each question carries **FIVE** marks.

- 7 (a) Explain heating effect of current and develop the formula for heat produced in a current carrying wire.
(OR)

(b) Develop an expression for balancing condition of Wheatstone bridge with legible sketch.

- 8(a) Develop expression for moment of couple on a bar magnet placed in a uniform magnetic field.
(OR)

(b) Classify magnetic materials based on their magnetic properties.

STATE BOARD OF TECHNICAL EDUCATION & TRAINING, TELANGANA
DIPLOMA EXAMINATION (C 24)
SEMESTER II
SEMESTER END EXAM
SC –203 Applied Physics
Model Question paper

Duration: 2 hours

Max.Marks: 40

PART-A

8 X 1 = 8

Instructions: 1. Answer **ALL** questions.
2. Each question carries **ONE** mark

1. What is the formula for maximum acceleration of a particle in S.H.M?
2. Define magnetic field.
3. Define critical angle.
4. What is audible range of human beings?
5. What is photo electric effect?
6. Define population inversion in LASER.
7. What is forbidden gap?
8. Define intrinsic semiconductors.

PART-B

4 X 3 = 12

Instructions: 1. Answer **ALL** questions.
2. Each question carries **THREE** marks.

9(a) The Simple Harmonic oscillations executed by a particle of mass 0.5 kg are represented by

the equation $y = 2 \sin \left(10t + \frac{\pi}{4} \right)$. Find (a) velocity when the displacement is 1 unit and (b) maximum acceleration.

(OR)

(b) List the applications of optical fibre.

10(a) Explain Coulomb's inverse square law of magnetism.

(OR)

(b) Explain the concept of Fermi level.

11(a) The work function of a photoelectric material is 3.3 eV. Calculate threshold frequency? Given Planck's constant $h = 6.6 \times 10^{-34}$ joule-sec, velocity of light $c = 3 \times 10^8$ ms⁻¹ and 1 eV = 1.6 x 10⁻¹⁹ joule.

(OR)

(b) Draw and label the diagram showing various regions of Electromagnetic spectrum in the order of increasing wavelength.

12(a) Explain valance band, conduction band and forbidden energy gap in solids.

(OR)

(b) Explain P-type and N-type semiconductors.

PART-C

4 X 5 = 20

- Instructions: 1. Answer **ALL** questions.
2. Each question carries **FIVE** marks.

13(a) Two tuning forks when sounded together give 5 beats per second. The frequency of the first fork is 480 Hz. When a piece of wax is attached to the second fork, the beats are reduced to 4. Find the frequency of the other tuning fork.

(OR)

(b) Develop laws of photoelectric effect.

14(a) Explain construction and working of transformer using the principles of electromagnetic induction with legible diagram.

(OR)

(b) Explain forward bias and reverse bias PN diode.

15(a) Identify the differences between step index and graded index optical fibers.

(OR)

(b) Identify applications of nano materials.

16(a) Construct full wave rectifier.

(OR)

(b) Draw a labeled diagram and explain working of Light Emitting Diode (LED).

SC 204: APPLIED ENGINEERING CHEMISTRY

Course Title	Applied Engineering Chemistry	Course Code	SC-204
Semester	II	Course Group	Foundation
Teaching Scheme in Periods (L:T:P)	4:1:0	Credits	2.5
Methodology	Lecture + Tutorial	Total Contact Periods	75
CIE	60Marks	SEE	40Marks

Prerequisite: Basic knowledge of Chemistry in Secondary Education.

Course Objective: After studying this course the student will be able to understand and appreciate the role of chemistry and environmental studies in different spheres of industries.

Course Outcome: On successful completion of the course, the students will have ability to attain below Course Outcomes (CO):

CO1	Explain the formation and functioning of Galvanic Cells, Batteries and Fuel Cells and apply the knowledge to identify and compare the materials best suited for construction of Batteries and Fuel Cells.
CO2	Explain the different metallurgical processes and apply the knowledge in the extraction of metals and in making alloys for industrial needs.
CO3	Explain the various corrosion processes, protection methods and apply the knowledge to reduce the corrosion in domestic and industrial areas.
CO4	Explain the different methods of preparation and characteristics of organic polymers and apply the knowledge to select suitable polymer for domestic and industrial use.
CO5	Identify the importance of Gaseous fuels, Lubricants, engineering materials and their uses for domestic and industrial applications.
CO6	Explain the causes, effects and controlling methods of air pollution, water pollution and soil pollution and apply relevant methods to solve domestic and industrial problems.

CO-PO Matrix:

CO	PO1	PO2	PO3	PO4	PO5	PO6	PO7
CO1	3	-	-	-	-	-	2
CO2	3	-	-	-	1	-	2
CO3	3	-	-	-	-	-	2
CO4	3	1	-	-	1	-	2
CO5	3	1	-	-	1	-	2
CO6	3	-	-	-	3	-	3

COURSE CONTENTS**UNIT – I: ELECTROCHEMICAL CELL– BATTERIES:****L10 + T3 Periods**

Galvanic cell–Standard electrode potential–Reference electrodes–Electro chemical series–EMF of cell– Batteries-Types of batteries–Leclanche cell, Lead storage battery – H₂-O₂ Fuel cells.

UNIT -II: MTALLURGY:**L10 + T2 Periods**

Characteristics of metals- Distinguish between metals and non metals - Mineral, Ore, Gangue, Flux, Slag - Concentration of ore, Methods of extraction of crude metal - Roasting, Calcination, Smelting, Extraction of Al, and Fe – Alloys-Purpose of making alloys – Composition and uses of Brass, Nichrome and Duralumin.

UNIT –III: CORROSION:**L10 + T2 Periods**

Corrosion-Factors influencing the rate of corrosion–Dry and wet theories of corrosion–Composition cell, Stress cell and Concentration cell-Rusting of iron and its mechanism-Prevention of corrosion– Protective coatings-Cathodic protection-Paints– Constituents of paint–Functions of constituents of paint.

UNIT–IV: POLYMERS:**L10 + T3 Periods**

Polymers - Polymerization - Types of polymerization – Addition polymerization, Condensation polymerization - Plastics - Types of plastics - Advantages of plastics over traditional materials - Disadvantages of using plastics- Preparation and uses of the following plastics: 1. Polythene 2.PVC 3.Urea formaldehyde 4. Bakelite - Compounding of plastics – Natural rubber – Vulcanization of natural rubber - Elastomers – Preparation and uses of Buna-s, Neoprene rubber - Biodegradable polymers-preparation and uses.

UNIT-V: INDUSTRIAL FUELS AND MATERIALS

L10 + T3 Periods

Definition and classification of fuels- Characteristics of good fuel-composition, calorific value, and uses of gaseous fuels- a) CNG b) LPG c) Bio gas – Lubricants– Classification and functions of lubricants – Engineering material -Glass-Properties- Manufacturing of glass-melting, Forming and shaping-Annealing -Finishing, Chemical components -uses of soft glass, hard glass, flint glass and laminated glass.

UNIT -VI: ENVIRONMENTAL POLLUTION AND CONTROL

L10 + T2 Periods

Air pollution-Introduction, Classification of air pollutants based on origin and states of matter, Causes, effects, and controlling methods - Water pollution – Causes, effects, controlling methods– Soil pollution – Causes, General effects,-Controlling methods –Carbon credit and carbon trading

Reference Books:

1. Engineering chemistry–Jain &Jain –Dhanpat Rai Publishing Company.
2. A Text book of Engineering Chemistry–S.S. Dara – S. Chand Publications.
3. Environmental Studies –A.K. De.
4. Environmental Studies, R. Rajagopalan,2nd Edition,2011, OxfordUniversityPress
5. Intermediate ChemistryIandII–TeluguAcademyTS
6. Engineering chemistry– Prasanta Rath, B.Ramadevi, Ch. Venkataramana Reddy & Subhendu Chakroborty–CENGAGE

E- Learning links:

<https://iupac.org/><https://www.khanacademy.org/www.nptel.ac.in>

Specific Learning Outcomes:

Upon completion of the course, the student will have ability to:

UNIT-I: ELECTROCHEMICAL CELL - BATTERIES

- 1.1. Define galvanic cell
- 1.2. Explain the construction and working of Daniel cell
- 1.3. Explain the differences between electrolytic cell and galvanic cell
- 1.4. Explain Electrode potential, Oxidation potential, reduction potential and standard electrode potential.
- 1.5. Define Reference electrode give examples.
- 1.6. Explain the construction and working of standard hydrogen electrode (SHE).
- 1.7. Explain the construction and working of calomel electrode
- 1.8. Define electrochemical series and explain its significance.
- 1.9. Define and explain EMF of cell and solve the numerical problems
- 1.10. Define battery and explain the types of batteries-Primary and secondary battery with examples
- 1.11. Explain the construction, working and applications of Dry cell (Leclanche cell) and Lead storage battery
- 1.12. Explain the construction, working and advantages of Hydrogen-Oxygen fuel cell

UNIT-II: METALLURGY

- 2.1 Identify the characteristics of metals.
- 2.2 Explain the differences between metals and non-metals
- 2.3 Define and explain the terms 1.Mineral 2.Ore 3.Gangue, 4.Fluxand 5.Slag -with examples
- 2.4 Explain the minerals and ores of Iron, and Aluminium.
- 2.5 Froth floatation and Electromagnetic separation methods for the concentration of ore
- 2.6 Explain the metallurgical processes -Roasting, Calcination, Smelting.
- 2.7 Extraction of Al from Bauxite (Flow chart)
- 2.8 Extraction of Fe from Hematite (flow chart)
- 2.9 Define an alloy and explain the purpose of making of alloys
- 2.10 Explain the composition and uses of following alloys i) Brass ii) Nichrome iii) Duralumin

UNIT –III: CORROSION

- 3.1 Define corrosion
- 3.2 Explain the factors influencing the rate of corrosion based on i) Nature of metal ii) Nature of environment of metal.
- 3.3 Explain the Electrochemical theory of corrosion.
- 3.4 Explain the formation of a) Composition cell b) Stress cell c) Concentration cell
- 3.5 Define rust and explain the mechanism of rusting of iron with chemical reactions.
- 3.6 Explain the following methods of prevention of corrosion:
 - a). Protective coatings i) Metallic coatings (Anodic coating and cathodic coating)
 - ii) Inorganic coatings iii) Organic coatings
 - b). Cathodic protection i) Sacrificial anode method ii) Impressed voltage method.
- 3.7 Define the term paint.
- 3.8 Explain the characteristics of a good paint.
- 3.9 List the constituents of paint (pigment, vehicle or drying oil, thinner, drier, filler and plasticizers) and explain the functions of constituents of paint.

UNIT–IV: POLYMERS

- 4.1 Define polymerization
- 4.2 Explain the types of polymerization (Addition polymerization and Condensation polymerization) with examples.
- 4.3 Define the term plastic
- 4.4 Identify the characteristics of plastics.
- 4.5 Summarize the advantages of plastics over traditional materials
- 4.6 Explain the impact of plastics on environment.
- 4.7 Explain the types of plastics with examples.
- 4.8 Identify the differences between thermo plastics and thermosetting plastics
- 4.9 Explain the methods of preparation and uses of the following plastics: 1. Polythene, 2. Polyvinylchloride, 3. Urea formaldehyde resin 4. Bakelite (Only flow chart for Bakelite i.e. without chemical equations).
- 4.10 Define the term natural rubber
- 4.11 Explain the processing of natural rubber from latex.
- 4.12 Explain the structural formula of natural rubber

- 4.13 Explain the characteristics of natural rubber
- 4.14 Explain the process of vulcanization of natural rubber with chemical reactions.
- 4.15 Interpret the characteristics of vulcanized rubber
- 4.16 Define the term elastomer
- 4.17 Explain the preparation and uses of the following synthetic rubbers a) Buna-S b) Neoprene rubber.
- 4.18 Define a biodegradable polymer and explain a method of preparation and uses of biodegradable polymer-polylactic acid and polycaprolactone.

UNIT-V: INDUSTRIAL FUELS AND MATERIAL

- 5.1 Define fuel.
- 5.2 Classify the fuels based on their physical state with examples.
- 5.3 Classify the fuels based on occurrence-primary and secondary fuels with examples.
- 5.4 Define calorific value
- 5.5 Calculate the oxygen required for combustion of methane and ethane gases
- 5.6 Explain the characteristics of a good fuel
- 5.7 Explain the advantages of gaseous fuels
- 5.8 Explain the chemical composition, calorific value and uses of a) CNG b) LPG c) Bio gas
- 5.9 Define lubricant.
- 5.10 Classify the lubricants based on physical state.
- 5.11 Explain the functions of lubricants.
- 5.12 Explain General characteristics of Glass.
- 5.13 Explain a method of manufacture of Glass -melting, Forming and shaping-Annealing - Finishing,
- 5.14 Explain the components and uses of the following commercial Glasses 1. Soft glass, 2. Hard glass, 3. flint glass, 4. Laminated glass.

UNIT -VI: ENVIRONMENTAL POLLUTION AND CONTROL

- 6.1 Define air pollution
- 6.2 Classify the air pollutants-based on origin and states of matter
- 6.3 Explain the causes of air pollution
- 6.4 Explain the effects of air pollution on human beings, plants and animals

- 6.5 Explain the Greenhouse effect- its consequences and control methods
- 6.6 Explain the Acid rain-its consequences and control methods
- 6.7 Explain the controlling methods of air pollution
- 6.8 Define water pollution
- 6.9 Explain the causes of water pollution
- 6.10 Explain the effects of water pollution on living and non-living things
- 6.11 Utilize the available methods to control water pollution.
- 6.12 Define soil pollution.
- 6.13 Explain the causes of soil pollution.
- 6.14 Explain the general effects of soil pollution.
- 6.15 Explain the methods of control of soil pollution.
- 6.16 Understand the concept of Carbon Credits and Carbon Trading (Elementary level only)
- 6.17 Understand the advantages and disadvantages of carbon trading

BOARD OF DIPLOMA EXAMINATIONS (C24)
SEMESTER EXAMINATION
MIDSEM– I

SC-204-ENGINEERING CHEMISTRY AND ENVIRONMENTAL STUDIES
Time: 1 Hour

Max.Marks:20

PART–A

Instructions: Answer **all** questions. Each question carries **one** mark
marks

4X 1=4

1. Define Galvanic cell.
2. What is standard electrode potential?
3. Define an ore.
4. Define Roasting.

PART–B

Instructions: Answer the **following** questions. Each question carries **three** marks

2x 3=6 Marks

5. a. Explain any three differences between Electrolytic cell and Galvanic cell
(OR)
- b. Explain the types of batteries with examples.
6. a. Explain Magnetic separation method of concentration of Ore.
(OR)
- b. Explain the purpose of making alloy (any six).

PART–C

Instructions: Answer the **following** questions. Each question carries **five** marks.

2x

5=10 marks

7. a. Explain the construction and working of Leclanche cell.
(OR)
- b. Define and explain EMF. Find the EMF of Cell $Zn / Zn^{2+} (1M) || Cu^{2+} (1M) | Cu$ Given E° of $Zn^{2+} | Zn = - 0.76V$ and E° of $Cu^{2+} | Cu = 0.34V$
8. a. Select a systematic process of extraction Fe from Hematite (Flow chart only).
(OR)
- b. Show the Chemical composition and explain the uses of following alloys a) Brass and
b) Nichrome

BOARD OF DIPLOMA EXAMINATIONS (C24)
SEMESTER EXAMINATION
MIDSEM-II

SC-204-ENGINEERING CHEMISTRY AND ENVIRONMENTAL STUDIES

Time: 1 Hour

Max.Marks:20

PART-A

Instructions: Answer **all** questions. Each question carries **one** mark
1=4 marks

4X

1. Define Corrosion.
2. What is a Paint?
3. Define polymerization
4. What is the chemical name of natural rubber?

PART-B

Instructions: Answer the **following** questions. Each question carries **three** marks

2x 3=6

Marks

5. a. Select any six characteristics of a good paint.
(OR)
b. Explain Sacrificial anode method of prevention of corrosion.
6. a. Write any three advantages of plastics over traditional materials.
(OR)
b. Write any three differences between thermo plastic and thermosetting plastic.

PART-C

Instructions: Answer the **following** questions. Each question carries **five** marks.

2x 5=10

marks

7. a. Explain any five factors influencing the rate of corrosion of metal.
(OR)
b. Explain any five constituents of a paint with their functions
8. a. What is vulcanization of rubber and explain with chemical equations.
(OR)
b. Explain preparation and uses of following plastics 1. Polyethene 2. PVC
(polyvinyl chloride)

BOARD OF DIPLOMA EXAMINATIONS (C24)
SEMESTER END EXAMINATION

SC-204-ENGINEERING CHEMISTRY AND ENVIRONMENTAL STUDIES

Time: 2Hour

Max. Marks: 40

PART-A

Instructions: Answer **all** questions. Each question carries **one** mark

8X 1=8 marks

1. What is electrochemical series?
2. What is the composition of Rust?
3. Define a Fuel
4. Define gangue.
5. Define a Lubricant
6. What is the composition of potash lime Glass?
7. Define air pollution.
8. Define water pollution.

PART-B

Instructions: Answer the **following** questions. Each question carries **three** marks
marks

4x3=12

9. a. Choose any six characteristics of Metals.
(OR)
b. Classify the Lubricants based on physical state. Give examples.
10. a. Identify any six advantages of plastics over traditional material.
(OR)
b. Explain any three methods of control of soil pollution.
11. a. Explain the classification of fuels based on physical state. Give examples.
(OR)
b. Explain the general characteristics of Glass (any six).
12. a. Explain the causes and effects of Greenhouse effect.
(OR)
b. Explain the effects of water pollution on Living things.

PART-C

Instructions: Answer the **following** questions. Each question carries **three** marks 4X5= 20 marks

13. a. Explain the construction and working of Hydrogen-Oxygen Fuel cell.
(OR)
b. Explain a method of manufacture of Glass with labelled diagram.
14. a. Identify any five differences between Thermoplastics and Thermosetting plastics
(OR)
b. Explain the controlling methods of water pollution.
15. a. Explain the chemical composition and uses of LPG and CNG fuels
(OR)
b. Explain the components and uses following Glasses
1. Lead glass.2.Soda lime glass3.Laminated Glass
16. a. Explain any five causes of Air pollution
(OR)
b. Explain any five methods of control of Water pollution

CS-205 :PROGRAMMING IN C

Course Title:	Programming in C	Course Code	CS-205
Semester	II	Course Group	CORE
Teaching Scheme in Periods (L:T:P)	4:1:0	Credits	2.5
Methodology	Lecture+Tutorials	Total Contact Periods	75
CIE	60 Marks	SEE	40 Marks

Pre requisites

Basic knowledge Of Mathematics, Logical, Reasoning and IT skills

Course Outcomes

Upon completion of the course, the student shall be able to

CO1	Develop Algorithms and Draw Flowchart for given problems.
CO2	Use Datatypes and classify Operators.
CO3	Develop Programs Using Decision Making Branching and looping statements.
CO4	Create Arrays, know the usage of strings.
CO5	Analyze and implement Modular Programming using Functions
CO6	Develop programs Using structures and Unions

Course Content and Blue Print of Marks for SEE

Unit No	Unit Name	Periods	Questions to be set for SEE			
			R	U	A	
I	Programming Methodology and Introduction to C Language	10	Q4	Q1	Q9(a)	Q13(a)
II	Understand Constants, Variables and Data types in C and Understand Operators and Expressions in C	10				
III	Decision making and Looping statements	14		Q2	Q10(a)	Q14(a)

IV	Arrays and Strings	14	Q3			
V	User Defined functions	13		Q5, Q6	Q9(b), Q11(a), Q11(b)	Q13(b), Q15(a), Q15(b)
VI	Structures and Unions	14		Q7, Q8	Q10(b), Q12(a), Q12(b)	Q14(b), Q16(a), Q16(b)
	Total	75		8	8	8

Course Contents

1. Programming Methodology and Introduction to C Language

Duration: 10 periods (L:8 – T:2)

Steps involved in problem solving - Define Algorithm - Characteristics of algorithm - Steps involved in algorithm development - Algorithms for simple problems - Define flowchart - Symbols used in flowchart - Flowcharts for simple problems - Differentiate algorithm and flowchart - Define Program - Differentiate between algorithm and program - Define High level language and low level language - Define Compiler, Assembler, Linker and Loader - Define source code, assembly code, object code, machine code - importance of C language - structure of C program - different stages in converting the C program source code into an executable code - steps in executing the C program.

2. Understand Constants, Variables and Data Types in C and Understand Operators and Expressions in C

Duration: 10 Periods (L:7 – T:3)

Character set - C Tokens - Keywords and Identifiers - Constants and Variables - data types and Classification - declaration of a variable - Assigning values to variables - Define operator - Classify operators - List and explain various arithmetic operators with examples - Illustrate the concept of relational operators - List logical operators - various assignment operators - Increment and decrement operators - List bitwise operators - Conditional operator - various special operators - precedence and associativity of operators - Define expression - Evaluation of Arithmetic expressions - Evaluation of Logical expressions - Evaluation of Relational expressions - type conversion techniques - Know Preprocessor directives - Know Header Files - Reading and writing characters - formatted input and output.

3. Decision making and Looping statements

Duration: 14 Periods (L:12 – T:2)

Decision making in C programming - simple if statement - if-else statement - nested if statement - else-if ladder - Switch statement - Classification of various loop statements - while loop - do-while loop - for loop - break and continue statements - nesting of loops - Comparisons of different loop statements.

4. Arrays and Strings

Duration: 14 Periods (L:11 – T:3)

Arrays - definition, types, declaration and initialization of One Dimensional - Array - Accessing the elements in the Array - 'accessing array out of bounds' problem - Reordering an array in ascending order - average of elements in an array - largest element in an array -

Declaration and initialization of two Dimensional Arrays - sample programs on matrix addition and matrix multiplication, transpose- Strings – Definition, Declaration and initialization of String variables - Reading of strings from terminal - writing strings to screen - String handling functions with sample programs

5. User defined functions Duration: 13 Periods(L:10 – T:3)

Function – Definition - Need for user defined functions - Advantages of functions - elements of function - Return values and their types - function prototype - function call - function definition – Scope, visibility and lifetime of variables in functions- storage classes- Functions with no arguments and no return values - functions with arguments with no return values - functions with arguments with return values - functions with no arguments with return values - Recursion - sample programs on recursion - passing arrays to functions

6. Structures and Unions Duration: 14 Periods(L:12 – T:2)

Structures and Unions Structure- Definition - Creating a structure - Declaring structure variables - Accessing the structure members - Concept of structure assignment - Find size of a structure - Nested structure - Structure as function arguments –structures vs. arrays – Array of structures - Structure containing arrays- array of structures containing arrays - Union and illustrate usage of a union – difference between Structures and Union.

Text Books

1.LetUsC	--	YeshwanthKanetkarBPBPublications
2.Programmingin ANSIC	--	E.Balaguruswamy TataMcGrawHill
3.ProgrammingwithC	--	GottfriedSchaum’outline
4.CThecomplete Reference	--	SchildtTataMcGraw Hill

Reference Books

1. The C Programming Language- Brian W. Kernighan,Dennis M.Ritchie- Pre Publicationntice Hall
2. Programming in C 3rd Edition-Sams Publishing- Steven G. Kochan- Sams Publishing
3. Expert C Programming: Deep Secrets-Peter Van Der Linden- Pearson Publications
4. C Programming: A Modern Approach. K.N. King- Norton Publications
5. Learn to Program with C- Noel Kalicharan- APress Publications

Suggested e-Learning Links

1. https://www.w3schools.com/c/c_intro.php?external_link=true
2. <https://www.geeksforgeeks.org/c-programming-language/>
3. <https://www.programiz.com/c-programming>
4. <https://www.javatpoint.com/c-programming-language-tutorial>
5. <https://www.freecodecamp.org/news/the-c-programming-handbook-for-beginners/>
6. <https://www.tutorialspoint.com/cprogramming/index.htm>

7. <https://www.codecademy.com/catalog/language/c>
8. <https://www.codechef.com/learn/course/c>
9. <https://archive.nptel.ac.in/courses/106/104/106104128/>
10. <https://www.youtube.com/watch?v=3QiItnIWmOM>
11. <https://www.digimat.in/nptel/courses/video/106105171/L01.html>
12. <https://www.digimat.in/nptel/courses/video/106105171/L07.html>

Suggested Learning Outcomes

For achieving the Course outcomes, the following learning outcomes must be achieved

CO1: Develop Algorithms and Draw Flowchart for given problems.

- 1.1 State different steps involved in problem solving
- 1.2 Define algorithm and know its characteristics
- 1.3 State the steps involved in algorithm development
- 1.4 Develop algorithms for simple problems.
- 1.5 Define flowchart and know symbols used in drawing flowcharts
- 1.6 Draw flowchart for simple problems.
- 1.7 Differentiate algorithm and flowchart
- 1.8 Define program and differentiate between program and algorithm
- 1.9 Define High level language and low level language
- 1.10 Define Compiler, Assembler, Linker and Loader
- 1.11 Define source code, assembly code, object code, machine code.
- 1.12 State the importance of C language
- 1.13 Explain the structure of C program
- 1.14 List and Explain different stages in converting the C program source code to executable code.
- 1.15 Explain the steps involved in executing the C program.

CO2: Use Datatypes and classify Operators.

- 2.1 Describe Character set, C Tokens-Keywords, Variables, Identifiers, Constants and Variables.
- 2.2 Define Data type.
- 2.3 Classify Primary data types and explain with examples
- 2.3 Write the syntax to declare and assigning values to variables.
- 2.4 Define operator.
- 2.5 Classify and explain operators with examples
- 2.6 Describe operator precedence and associativity of operators.

- 2.7 Define expression.
- 2.8 Describe evaluation of Arithmetic, Relational and logical expressions.
- 2.9 Illustrate type conversion (implicit and explicit) techniques.
- 2.10 Define and List Pre-processor directives
- 2.11 Discuss #include and #define Pre-processor directives.
- 2.12 Define Header file and discuss stdio.h, conio.h, math.h, string.h Header files.
- 2.13 Illustrate getch(),putchar(),scanf(),printf() with programs.

CO3: Develop Programs Using Decision Making Branching and looping statements.

- 3.1 Discuss decision making in programming
- 3.2 Explain decision making statements- if, if-else, nested if-else, else-if ladder - with syntax and programs.
- 3.3 Explain decision making statement- switch statement - with syntax and programs.
- 3.4 Define looping and list loop statements.
- 3.5 Discuss the iterative statements – while, do- while, for statement- with syntax and programs.
- 3.6 Discuss break and continue statements.
- 3.7 Compare and Contrast break and continue statements.
- 3.8 Define Nested loops.
- 3.9 Develop programs using Nested loops.
- 3.10 Compare different loop statements.

CO4:Create Arrays, know the usage of strings.

- 4.1 Define an Array.
- 4.2 List different types of Arrays.
- 4.3 Declare and initialize One Dimensional Array with example program.
- 4.4 Develop a program to read, access and display the elements of a one dimensional array
- 4.5 Develop a program to sort the elements in ascending or descending order using one-dimensional Array.
- 4.6 Develop a c program to count the even and odd numbers for a given array of n elements.
- 4.7 Declare and initialize two Dimensional Arrays with example program.
- 4.8 Illustrate the concept of two dimensional arrays with the following programs
 - a. Matrix addition, subtraction
 - b. Matrix multiplication
 - c. Transpose of a matrix and check whether the given matrix is symmetric or not.

- 4.9 Define String
- 4.10 Declare and initialize a String variable.
- 4.11 Outline the different ways of reading and writing strings using scanf(), getchar(), gets(), printf(), putchar(), puts() functions.
- 4.12 Create a program to concatenate, copy, and finding out the length of a string without using string handling functions.
- 4.13 Explain about various String handling functions with sample programs.
- 4.14 Develop C programs using different string handling functions.

CO5: User defined functions and Applications

- 5.1 Define function,
- 5.2 Discuss the need of functions.
- 5.3 List out the advantages of functions.
- 5.4 Identify the elements of function.
- 5.5 Define and discuss function prototype, function call, and function definition with syntax and program.
- 5.6 Discuss the scope, visibility and lifetime of variables in functions.
- 5.7 Classify different storage classes.
- 5.8 Illustrate functions with no arguments and no return values with syntax and example programs.
- 5.9 Illustrate functions with no arguments and with return values with syntax and example programs.
- 5.10 Illustrate functions with arguments and with no return values with syntax and example programs.
- 5.11 Illustrate functions with arguments and with return values with syntax and example programs.
- 5.12 Illustrate passing arrays to functions as arguments with example programs.
- 5.13 Define recursion.
- 5.14 Develop the following programs using recursion
 - a. Factorial of a number.
 - b. compute x^n (hint : x raised to the power n).
 - c. Fibonacci series.

CO6: Develop programs Using structures and Unions

- 6.1 Define structure
- 6.2 State the uses of structures.
- 6.3 Declaration and initialization of a structure template and structure variables.

- 6.4 Explain accessing structure members using (.) dot operator.
- 6.5 Develop a C program to create, initialize a structure and access its data members.
- 6.6 Syntax to know the size of a structure.
- 6.7 Discuss nested structure concept.
- 6.8 Illustrate the concept of nested structure with a program.
- 6.9 Know the differences between Structures and Arrays.
- 6.10 Illustrate array of structures, structures containing arrays, array of structures containing arrays.
- 6.11 Illustrate array of structures using sample C program.
- 6.12 Illustrate structure as function arguments and returning of structure variables as function values.
- 6.13 Define Union.
- 6.14 State the usage of unions.
- 6.15 Declaration and initialization of a union.
- 6.16 Explain accessing of union members using (.) dot operator.
- 6.17 Know the differences between Structure and Unions.

Suggested Student Activities

Student activity like mini-project, surveys, quizzes, etc. should be done in group of 5-10 students.

1. Each group should do any one of the following type of activity or any other similar activity related to the course with prior approval from the course coordinator and programme coordinator concerned.
2. Each group should conduct different activity and no repetition should occur.
3. Explore and analyse topics to improve the level of creativity and analytical skill by taking Quiz/ tests/ assignments. Documents have to be maintained as a record.
4. Create a power point presentation on the topic relevant to course or advanced topic as an extension to the course to improve the communication skills. Documents have to be maintained as a record.
5. Visit different sites relevant to topics. Listen to the lectures and submit a handwritten report
6. Coding competitions

CO-PO Mapping Matrix

	Basic and Discipline Specific Knowledge	Problem Analysis	Design/Development of Solutions	Engineering Tools, Experimentation and Testing	Engineering Practices for Society, Sustainability and Environment	Project Management	Lifelong Learning	Linked PO
CO	PO1	PO2	PO3	PO4	PO5	PO6	PO7	
CO1	2	1	1			1	1	1,2,3,6,7
CO2	2					1	2	1,6,7
CO3	2	1	2	1	1	2	2	1,2,3,4,5,6,7
CO4	2	2	2	1	1	1	2	1,2,3,4,5,6,7
CO5	2	2	2	1	3	2	2	1,2,3,4,5,6,7
CO6	2	1	1			1	2	1,2,3,6,7

State Board of Technical Education and Training, Telangana
Model Question paper
PROGRAMMING IN CII-SEMESTER
Mid Semester-I Examination

Course Code: CS-205
Course Name: Programming in C

Duration:1 hour
Max.Marks: 20 Marks

PART-A

Answer all questions- Each Question carries ONE mark
Marks

4x1 = 4

1. List any two differences between algorithm and flowchart.
2. Define Low level language
3. List various types of constants.
4. Define an expression

PART-B

Answer two questions- Each Question carries THREE marks
Marks

2x3 = 6

- 5.a) List out any 6 symbols used in Flowchart.
(OR)
- b) Write any three differences between high level language and low level language
- 6.a) Write the syntax to declare variable in C? Give examples.
(OR)
- b) Evaluate an expression $(2+5)*(10-4)\%10$.

PART-C

Answer two questions- Each Question carries FIVE marks

2x5 = 10 Marks

- 7a) Draw a flowchart to find factorial of given number N.
(OR)
- b) Explain the stages to execute a C-Program
- 8a) Explain different data types in C with examples.
(OR)
- b) Elaborate any three categories of operators in C.

State Board of Technical Education and Training, Telangana
Model Question paper
PROGRAMMING IN C II-SEMESTER
Mid Semester-II Examination

Course Code: CS-205
Course Name: PROGRAMMING IN C

Duration: 1 hour
Max.Marks: 20 Marks

PART-A

Answer all questions- Each Question carries ONE mark
Marks

4x1 = 4

1. Writethe syntaxof ifstatement.
2. Givethe syntax of whilestatement inC.
3. Definean array.
4. Givethesyntax fordeclaringandinitializingof onedimensionalarray.

PART-B

Answer two questions- Each Question carries THREE marks
Marks

2x3 = 6

5a) Explain switch statement with syntax.

(OR)

5b) Writeanythreedifferences betweenwhileand do-whilestatements.

6a) WriteaCprogramtofindlargest numberinarray.

(OR)

6b) Explain anythreeStringhandlingfunctions.

PART-C

Answer two questions- Each Question carries FIVE marks

2x5 = 10 Marks

7a) Explaindo-whilestatementwithsyntaxandsampleprogram

(OR)

7b) Write a C program whether a given number is Armstrong or not using while loop

8. a WriteaCprogramto multiplytwomatrices.

(OR)

8.b Write a C program to check whether given string is palindrome or not.

State Board of Technical Education and Training, Telangana
Model Question paper
PROGRAMMING IN C II-SEMESTER
Semester End Examination

Course Code: CS-205
Course Name: Programming in C

Duration: 2 hour
Max.Marks: 40 Marks

PART-A

Answer all questions- Each Question carries ONE mark

8x1 = 8 Marks

1. List any two differences between algorithm and program.
2. Give the syntax of simple if statement in C.
3. List any two advantages of functions.
4. Give the syntax for declaring and initializing of one dimensional array.
5. Define function.
6. Define recursion.
7. Write any two uses of structures.
8. Define Union?

PART-B

Answer Four questions- Each Question carries THREE marks

4x3 = 12 Marks

9. a) Write any three characteristics of algorithm.
(OR)
9. b) Write any three advantages of functions.
10. a) Write any three differences between break and continue statements.
(OR)
10. b) Write any three differences between structure and union statements.
11. a) Explain elements of function in C.
(OR)
11. b) Write any three differences between local variable and global variable statements.
12. a) Explain how to access structure members.
(or)
- b. Compare structure and arrays.

PART-C

Answer Four questions- Each Question carries FIVE marks

4x5 = 20 Marks

13. a) Explain the structure of a C-Program.

(OR)

13. b) Write a C program to compute the transpose of given matrix.

14. a) Write a C program to sort the elements of a one-dimensional array.

(OR)

14. b) Write a C program to access the elements of a union.

15. a) Write a C program to illustrate functions with arguments and without return values.

(OR)

15. b) Write a C program to find the factorial of a number using recursion.

16. a) Write a C program to implement nested structures.

(OR)

b) Write a C program to implement array of structures.

ME-206 MANUFACTURING TECHNOLOGY

Course title:	Manufacturing Technology	Course code:	ME-206
Semester:	II	Course group:	Core
Teaching scheme in periods:	4:1:0	Credits:	2.5
Methodology:	Lecture + Tutorial	Total Contact periods:	75
CIE:	50 Marks	SEE:	40 Marks

Prerequisites

Enthusiasm to learn the course and requires the basic knowledge of Basic work shop

COURSE OUTCOMES

On successful completion of the course, the student's will be able to:

COURSE OUTCOMES	
CO1	Attain the knowledge effectively operate a lathe machine and produce high-Quality machined components in various manufacturing industries.
CO2	Grasp the fundamental principles of drilling required to effectively operate drilling machines and gain knowledge necessary to effectively utilize cutting fluids in machining operations.
CO3	Attain the concept of milling machine, types of milling machines, Milling cutters and contribute effectively to manufacturing industries.
CO4	Illustrate the Working of Grinding Process and apply for engineering applications. Understand various surface finishing processes and apply for various applications
CO5	Attain knowledge of identifying types of welding welding operations safely, efficiently, and to industry standards, thereby preparing them for careers in welding and fabrication across various sectors.
CO5	Identify the Press tools and apply it in various engineering applications & Identify Special tools for Work holding and guiding for different machining processes

BLUE PRINT OF MARKS FOR SEE

Unit No	Unit Name	Periods	Questions to be set for SEE			
			R		U	A
1	Lathe and lathe works	12	Q4	Q1	Q9(a)	Q13(a)
2	Drilling and cutting fluids	13				
3	Milling	12		Q2	Q10(a)	Q14(a)
4	Grinding and finishing	13				
5	Welding	13	Q3	Q5,Q5	Q9(b), Q11(a), Q11(b)	Q13(b), Q15(a), Q15(b)
5	Press tool s jigs and fixtures	12				
Total		75	08		08	08

CO-PO Matrix

	PO1	PO2	PO3	PO4	PO5	PO6	PO7	Mapping POs
CO1	3	3	3	2	-	1	1	1, 2,3,4,6,7
CO2	3	3	3	2	1	-	1	1, 2,3,4,5,7
CO3	3	3	3	2	-	-	2	1, 2,3,4,7
CO4	3	3	3	2	-	2	1	1,2 4,6, 7
CO5	3	3	3	2	-	1	2	1,2, 4,6,7
CO6	3	3	3	2	1	1	3	1,2,3,4,5,6,7

COURSE CONTENT

UNIT– I

LATHE & LATHEWORKS

PERIODS:12

Working Principle of Lathe, Types of Lathes - Engine lathe – construction details– specifications, geometry and nomenclature of single point cutting tool, tool signature, Cutting speed, feed, depth of cut, cutting tool materials, General and special operations – (Turning, facing, taper turning thread cutting, knurling, forming, drilling, boring, reaming, key way cutting). Explanation Lathe accessories viz., work holding devices and tool holding devices.

UNIT–II

DRILLING AND CUTTING FLUIDS

PERIODS:13

Drilling: Introduction, classification of drills, twist drills, straight flute drills, common forms of parallel shank drills, taper shank twist drills, drill size and specifications, Working principle of drilling, Type of drilling machines: sensitive drilling machine, upright drilling machine (single spindle), radial drilling machine. Operations-Drilling, reaming, boring, counterboring, counter sinking, tapping, spot facing and trepanning

Cutting Fluids and coolants : Properties and functions of fluids and coolants and their uses, Types of cutting fluids, Fluids and coolants required in turning, drilling, shaping, sawing & broaching; Selection of cutting fluids, methods of application of cutting fluid

UNIT –III

MILLING

PERIODS:12

Milling : Milling cutter - Purpose – Working principal - Classification – Applications - Column and knee type-plain universal milling machine-vertical milling machine-specification of milling machines - principles of operation-work and tool holding devices-arbor-stub arbor spring collet-adapter- various milling operations – plain – face – straddle milling-gang milling-form milling-profile –end –saw - keyway –gear cutting –flute –cam milling

UNIT-IV

GRINDING AND FINISHING

PERIODS:13

Grinding Introduction – working Principles of Metal Removal by Grinding-Purpose of grinding – advantages –disadvantages - types of abrasives - bonding materials types – binding processes: Vittrified, silicate, shellac, rubber,-grit ,grade and structure of wheels - Standard marking systems: Meaning of letters numbers sequence of marking – Grades of letters. Grinding machines – classification: Cylindrical, Surface, Principle of centre less grinding, Advantages & limitations of centre less grinding - Dressing and trimming of grind wheels

Other Finishing processes Honing, Lapping, Super finishing, Electroplating–Basic principles–Plating metals–applications, Hot dipping: Galvanizing, Tin coating, Parkerizing, Anodizing

UNIT-V**WELDING****PERIODS:13**

Introduction & classification of welding processes. Applications, Advantages and limitations of welding, Principles of arc welding, Arc welding equipment, Choice of electrodes for different metals, Principle of gas (oxy – acetylene) welding. Equipment of gas welding. Welding procedures(arc & gas), defects in welding - testing and inspection

UNIT-VI**PRESS TOOLS JIGS AND FIXTURES****PERIODS 12**

Press tools :-Introduction - Types of Presses – hand, power, gap, inclinable, adjustable, horn, straight side, pillar presses - Constructional details of a power press-Press size. Press Tools – Punch and die-Press working operations- blanking, piercing and forming, lancing, cutting off and parting, notching, shaving, trimming, embossing, beading and curling, bulging, twisting, coining, swaging, hole flanging or extruding –line sketches

Jigs & fixtures:- Need and Applications of jigs & fixtures - Basic principles of location - Explain the locating methods and devices. Explanation of basic principles of the clamping - Types of clamps – strap clamps, cam clamps, screw clamps, toggle clamps, hydraulic and pneumatic clamps- Types of jigs - template jig, plate jig, leaf jig, box and handle jig, Indexing jig, Universal jig, vice jigs. Types of fixtures: milling & boring fixtures.

SUGGESTED LEARNING OUTCOMES:

Upon completion of the course the student shall be able to;

I. LATHE AND LATHE WORKS.

- 1.1. State the working principle of lathe
- 1.2. Identify Function of lathe
- 1.3. Categorize lathes
- 1.4. Interpret the Specification of lathe machine
- 1.5. Draw the line diagram of engine lathe and describe the functions of each part in lathe.
- 1.6. Explain in detail about lathe bed, head stock
- 1.7. Explain the details of the tailstock, carriage
- 1.8. Explain the details about the feed rod and lead screw
- 1.9. Identify various single point Cutting tool materials and effect of alloying elements
- 1.10. Explicate the Nomenclature of single point tool with the help of legible sketch
- 1.11. Explicate the Significance of various angles like rake angle, clearance angle
- 1.12. Cognize the effect Cutting speed, feed, depth of cut on metal removal rate and surface finish
- 1.13. Record the various operations performed on lathe including special operations.
- 1.14. Explain the lathe operation centering, facing

- 1.15. Describe the lathe operation different turning operations
- 1.16. Explain the lathe operations like drilling ,boring ,reaming ,and chamfering
- 1.17. Illustrate the lathe operations like knurling and parting off
- 1.18. Catalog and identify the purpose of different work holding devices
- 1.19. Explain the lathe centre
- 1.20. Explain the drive plate ,carriers and face plate with sketches
- 1.21. Explain the in detail about 3 jaw chuck and 4 jaw chuck with sketches
- 1.22. Differentiate between 3 jaw and 4jaw check
- 1.23. Explain the about magnetic ,collet, drill chuck
- 1.24. Explain the details about angle plate and mandrels
- 1.25. Record and lineup the purpose of different tool holding devices like grinding ,milling ,taper attachment

II. DRILLING AND CUTTING FLUIDS

- 2.1. State the meaning of drilling.
- 2.2. Categorize different types of drilling machines.
- 2.3. Explain about portable drilling machine
- 2.4. Comprehend the construction and working of sensitive drilling machine
- 2.5. Grasp the construction and working of radial drilling machine.
- 2.6. Record various types of drills and their purpose
- 2.7. Interpret the construction and working of Twist drill only
- 2.8. Identify forms of drill shank such as straight and taper shank and its purpose
- 2.9. Explain the twist drill nomenclature
- 2.10. Explain the designation of drill
- 2.11. Identify various drill bit materials
- 2.12. Write the specifications of drilling machines.
- 2.13. Record the different operations on drilling machine.
- 2.14. Explain the drilling machine operations like drilling ,boring ,reaming
- 2.15. Explain the drilling machine operations like counter boring ,counter sinking ,tapping
- 2.16. Explain the drilling machine operations like spot facing ,trepanning
- 2.17. Identify different Properties and functions of cutting fluids
- 2.18. Record the uses and the Types of cutting fluids.
- 2.19. Identify Fluids and coolants required in turning, drilling, shaping, sawing & broaching;
- 2.20. Identify the Selection of cutting fluids and
- 2.21. Identify the methods of application of cutting fluid

III MILLING

- 3.1 State the purpose of the milling
- 3.2 State the working principle of the milling
- 3.3 Record the Types of milling machines
- 3.4 Record the applications of milling machines
- 3.5 Identify the types of milling machines

- 3.6 Cognize construction and working of column and knee type-plain milling machines
- 3.7 Be acquainted with the construction and working universal milling machine
- 3.8 Illustrate the construction and working vertical milling machine
- 3.9 Record the specification of milling machine
- 3.10 Identify work holding devices and their purpose
- 3.11 Explain the work holding devices like vices, clamps and T – bolts.
- 3.12 Explain the work holding devices like v blocks, angle plates.
- 3.13 Explain the work holding devices like dividing head and special milling fixture
- 3.14 Identify tool holding devices and their purpose
- 3.15 Explain the arbor and collets
- 3.16 Explain the adapter and spring collet
- 3.17 Perceive about Various Milling operations
- 3.18 Explain the plain ,face , straddle milling
- 3.19 Explain the gang-angular-form-profile-end-saw milling operations
- 3.20 Explain about keyway –gear cutting-flute milling –cam milling operation

IV. GRINDING AND FINISHING

- 4.1 Comprehend the principle of metal removal by grinding.
- 4.2 Catalog the purpose of grinding
- 4.3 Record the different types abrasives like natural and artificial
 - 4.4 Explain the types of natural abrasives with examples
 - 4.5 Explain the artificial abrasives like Silicon Carbide and Aluminum Oxide
 - 4.6 Comprehend the bonding materials used in grinding wheel
 - 4.7 Elaborate the grit size in grinding wheels
 - 4.8 Explain the grades associated with grinding wheel
 - 4.9 Explain about vitrified, silicate bond
 - 4.10 Explain about shellac ,resinoid bond
 - 4.11 Perceive the designation of grinding wheel
 - 4.12 State the factors for selecting the grinding wheels.
 - 4.13 Record the classification of grinding machines.
 - 4.14 Comprehend the working and construction of Cylindrical grinding
 - 4.15 Explain about center less grinding
 - 4.16 Explain about mounting in wheel maintenance
 - 4.17 Differentiate between loading and glazing in grinding wheel
 - 4.18 Explain about dressing in grinding wheel
 - 4.19 Explain about star wheel dresser
 - 4.20 Explain about star diamond wheel dresser
 - 4.21 Illustrate the working and construction of surface grinding
 - 4.22 Record the different finishing processes
 - 4.23 Explain about honing ,lapping ,super finishing
 - 4.24 Comprehend the principle of electro–plating with a legible sketch.
 - 4.25 Record the different hot dipping processes
 - 4.26 Explain the galvanizing
 - 4.27 Explain the tin coating
 - 4.28 Explain the Parkerizing and anodizing
 - 4.29 List and understand the processes of various organic coatings

- 4.30 State the principles of metal spraying.
- 4.31 Select the appropriate process for surface roughness of a given application

V. WELDING

- 5.1 State the necessity of welding.
- 5.2 State the applications of welding
- 5.3 State the advantages and limitations of welding
- 5.4 Record the classification of welding
- 5.5 Explain the principle of arc welding
- 5.6 Explain the MMAW
- 5.7 State The Applications of MMAW
- 5.8 State and explain the equipment of arc welding.
- 5.9 State and explain the accessories of arc welding
- 5.10 State and explain DC welding methods(SP &RP)
- 5.11 State and explain the tools of arc welding
- 5.12 Explain the selection of electrodes
- 5.13 Explain the principle of gas welding.
- 5.14 Record and explain the tools of gas welding
- 5.15 Record and explain the equipment of gas welding
- 5.16 Explain types of flames in gas welding
- 5.17 Explain the different types of gas welding techniques
- 5.18 Explain The Welding Safety and practice
- 5.19 Record the welding defects
- 5.20 Explain the welding defects like undercut, lack penetration
- 5.21 Explain the welding defects like slag inclusion , porosity
- 5.22 Explain the welding defects like weld crack and spatter
- 5.23 Explain the welding defects like poor fusion and distortion
- 5.24 Record the different welding testing and inspection methods
- 5.25 Explain the visual inspection , radiography test in welding inspection
- 5.26 Explain about ultrasonic testing
- 5.27 Explain about magnetic and liquid penetrant test

VI. PRESS TOOLS JIGS AND FIXTURES

- 6.1 Comprehend the Importance of Press Tools
- 6.2 Record Classify presses based on power and design of frame.
- 6.3 Explain the constructional details of a power press with the help of a legible sketch
- 6.4 State the meaning of Press size.
- 6.5 Identify the Press Tools–Punch and die.
- 6.6 Describe various press working operations.
- 6.7 Explain blanking, piercing and forming,
- 6.8 Explain lancing, cutting off and parting,
- 6.9 Explain notching, shaving, trimming,

- 6.10 Explain embossing, beading and curling.
- 6.11 Explain twisting, coining, swaging, hole flanging or extruding
- 6.12 Explain hole flanging or extruding , bulging
- 6.13 State and explain various die operations
- 6.14 State punch and die materials
- 6.15 Explain the types of jigs their constructional details with the help of legible sketches
- 6.16 State general considerations in design of drill jigs
- 6.17 List different types of fixtures such as milling boring fixtures
- 6.18 Explain the milling fixture with sketch
- 6.19 Explain boring fixtures with sketch
- 6.20 Differentiate between jigs and fixtures.
- 6.21 List the advantages of Jigs and Fixtures
- 6.22 Comprehend basic principle of location.
- 6.23 Identify different locating methods and devices.
- 6.24 Explain the basic principle of clamping.
- 6.25 Identify different types of clamps

REFERENCE BOOKS

1. Production Technology by Jain & Gupta (Khanna Publishers)
2. Elementary Workshop Technology (Vol.I & II) by Hazra Chowdary
3. Manufacturing Technology (Vol.I) by P N Rao (McGraw-Hill)
4. Workshop Technology (Vol.I& II) by Raghuvamshi
5. Production Technology by P.C.Sharma
6. Production Technology (Volume I & II) – O. P. Khanna & Lal, Dhanpat Rai Publications.
7. Fundamental of metal cutting and machine tools– B. L. Juneja, New age international limited.
8. Manufacturing Technology, Metal Cutting & Machine tools– P. N. Rao, Tata McGraw-Hill Publications
9. Production Technology – R.B. Gupta, Satya Prakashan, New Delhi

Suggested E-Learning references

1. <http://www.asme.org>
2. www.ocw.mit.edu/courses/mechanical-engineering
3. www.nptel.ac.in
4. Grinding process <https://www.youtube.com/watch?v=Vcfau3bJ8hE>
5. Milling machine operation <https://www.youtube.com/watch?v=2jc3HkrHh9s>
6. Center less grinding https://www.youtube.com/watch?v=LfbNFTyGW_c
7. Truing and dressing of a Grinding wheel <https://www.youtube.com/watch?v=GOR35qroeew>
8. Manual press <https://www.youtube.com/watch?v=nTshp3STG9M>
9. Hydraulic press <https://www.youtube.com/watch?v=JxJUPD-Ajnc>
10. Die and types <https://www.youtube.com/watch?v=qTuPkrfZB00>
11. Jigs and fixtures <https://www.youtube.com/watch?v=CA3GnfImGmw>

ME-207 : ENGINEERING DRAWING - II

(This Course is Common to all programs of Diploma in Level offered by the State Board of Technical Education, Hyderabad, Telangana State)

Course Title	Engineering Drawing -II	Course Code	ME-207
Semester	II	Course Group	Practical
Teaching Scheme in Periods (L:T:P)	1:0:2	Credits	1.25
Methodology	Teaching + Practice	Total Contact Periods:	45
CIE	60 Marks	SEE	40 Marks

Pre-requisites: Knowledge of Basic Engineering Drawing pictorial intelligence to learn this course.

COURSE OUTCOMES (CO)

Upon successful completion of the course, the students will be able to

	Course Outcome	Cognizant Level	Linked Program Objectives (PO)
CO1	Draw the specified projections of solids for the given 3D representation of the regular solids	R / U / A	1, 2, 3, 4, 7
CO2	Create sectional views using cutting-plane lines and appropriate section lining.	R / U / A	1, 2, 3, 4, 7
CO3	Practice drawing auxiliary views of engineering components, ensuring accuracy and alignment with other views.	R / U / A	1, 2, 3, 4, 7
CO4	Create detailed engineering drawings that include isometric views to provide a comprehensive understanding of component geometry.	R / U / A	1, 2, 3, 4, 7
CO5	Identify different types of surfaces and their corresponding development methods, such as cylindrical, conical, and spherical surfaces.	R / U / A	1, 2, 3, 4, 6,7
CO6	Appraise the drawing principles and appreciate its applications in engineering field.	R / U / A	1, 2, 3, 4, 7

BLUEPRINT OF MARKS FOR SEE

Unit No	Name of the Unit	Periods	Questions to be set for SEE		
			R	U	A
			PART-A (2M Questions)		PART-B (6 M Questions)
1	Projection of Solids	08	Q1	Q9(a)	
2	Sectional Views	08	Q2	Q9(b)	
3	Auxiliary views	06	Q3	Q10(a)	
4	Pictorial drawing	09	Q4	Q10(b)	
5	Development of surfaces	14	Q5, Q6, Q7, Q8	Q11(a), Q11(b), Q12(a), Q12(b)	
Total Periods / Total Questions		45	8	4	
<p>[R: Remembering, U: Understanding – 2 Marks] [A: Application – 6 Marks]</p> <p><u>Note:</u> Question Paper consists PART – A and PART-B, Total Marks: 40, Time: 2 Hours</p> <p>PART – A consists of 8 and student have to answer ALL questions, each question carries 2 marks (8x2 = 16)</p> <p>PART – B consists of 4 questions and student have to answer ALL questions, each question carries 6 marks (4x6=24)</p>					

CIE Question Paper Pattern and Syllabus

Unit No	Unit Name	Questions to be set for CIE		
		R	U	A
		2M Questions		6M Questions
Mid Semester - I				
1	Projection Solids	Q1, Q2		Q5(a), Q5(b),
2	Sectional Views	Q3, Q4		Q6(a), Q6(b)
	Total	4		2
Mid Semester - II				
3	Auxiliary views	Q1, Q2		Q5(a), Q5(b),
4	Pictorial drawing	Q3, Q4		Q6(a), Q6(b)
	Total	4		2
[R: Remembering, U: Understanding – 2 Marks] [A: Applying – 6 Marks]				
<p><u>CIE Question Paper Pattern: Total Marks: 20, Time: 1 Hour</u>Maximum</p> <p>Marks: 20, Time: 1 Hour</p> <p><u>Part A:</u> Consists of 4 Short questions, students have to attempt ALL questions and each question carries 2 Marks. (4 x 2 = 8 Marks)</p> <p><u>Part B:</u> Consists of 2 Essay type questions, students have to attempt ALL questions and each question carries 6 Marks.(2 x 6 = 12 Marks)</p>				

COURSE CONTENT

1.0 Projection of solids

(08 periods)

Projection of regular solids

- a) Axis perpendicular to one of the planes
- b) Axis parallel to VP and inclined to HP and vice versa.

2.0 Sectional views

(08 periods)

Need for drawing sectional views – what is a sectional view - Location of cutting plane – Purpose of cutting plane line – Selection of cutting plane to give maximum information (vertical and offset planes) - Hatching – Section of regular solids inclined to one plane and parallel to other plane

3.0 Auxiliary views

(06 periods)

Need for drawing auxiliary views -Explanation of the basic principles of drawing an auxiliary views - explanation of reference plane and auxiliary plane -Partial auxiliary view.

4.0 Pictorial Drawings

(09 periods)

Brief description of different types of pictorial drawing viz., Isometric, oblique, and perspective and their use - Isometric drawings: Iso axis, angle between them, meaning of visual distortion in dimensions - Need for an isometric scale, difference between Isometric scale and ordinary scale difference between Isometric view and Isometric projection - Isometric and non-Isometric lines -Isometric drawing of common features like rectangles, circular shapes, non-isometric lines - Use of box and offset methods.

5.0 Development of Surfaces

(14 periods)

Need for preparing development of surface with reference to sheet metal work - Concept of true length of a line with reference to its orthographic projection when the line is (i) parallel to the plane of projection (ii) inclined to one principal and parallel to the other -Development of simple solids like cubes, prisms, cylinders, cones, pyramid (sketches only) -Types of development: Parallel line and radial line development -Procedure of drawing development, drawings of trays, funnels, elbow pipes and rectangular ducts.

REFERENCE BOOKS

1. Engineering Drawing by Kapil dev – (Asian Publisher)
2. Engineering Drawing by Basant Agarwal&C.M Agarwal - (McGraw-hill)
3. Engineering Drawing by N.D.Bhatt. (Charotar Publishing House Pvt. Ltd.)
4. A Textbook on Engineering Drawing by P. Kannaiah, K. L. Narayana, K. Venkata Reddy
5. Engineering drawing + AutoCAD by Venugopal, K, New Delhi : New Age International

ONLINE RESOURCES

1. <https://nptel.ac.in/courses>
2. <https://nptel.ac.in/courses/124107159>
3. www.slideshare.net/shameem.mist/engineering-drawing
4. https://www.powershow.com/viewfl/76303aOWI5M/Engineering_Drawing_powerpoint_ppt_presentation
5. https://www.powershow.com/view0/91a2bfN2Q2N/Basic_engineering_drawing_solved_question_powerpoint_ppt_presentation

PECIFIC LEARNING OUTCOMES

1.0 Apply Principles of Projection of solids

- 1.1. Draw the projections of solids to axis of solids parallel to one plane.
- 1.2. Draw the projections of solids to axis of solid inclined to other plane.

2.0 Appreciate the need of Sectional Views

- 2.1 Explain the need to draw sectional views.
- 2.2 Select the section plane for a given component to reveal maximum information.
- 2.3 Explain the positions of section plane with reference planes
- 2.4 Differentiate between true shape and apparent shape of section
- 2.5 Draw sectional views and true sections of regular solids discussed in 6.0
- 2.6 Apply principles of hatching.

3.0 Understand the need of auxiliary views

- 3.1 State the need of Auxiliary views for a given engineering drawing.
- 3.2 Draw the auxiliary views of a given engineering component
- 3.3 Differentiate between auxiliary view and apparent view

4.0 Prepare pictorial drawings

- 4.1 State the need of pictorial drawings.
- 4.2 Differentiate between isometric scale and true scale.
- 4.3 Prepare Isometric views for the given orthographic drawings.

5.0 Interpret Development of surfaces of different solids

- 5.1 State the need for preparing development drawing.
- 5.2 Prepare development of simple engineering objects (cubes, prisms, cylinders, cones, pyramid) using parallel line and radial line method.
- 5.3 Prepare development of surface of engineering components like trays, funnel, 90° elbow & rectangular duct.

COURSE-PO ATTAINMENT MATRIX

CO	PO1	PO2	PO3	PO4	PO5	PO6	PO7
CO1	3	2	2	2	-	-	3
CO2	3	3	3	2	-	-	3
CO3	3	3	3	2	-	-	3
CO4	3	2	3	3	-	-	3
CO5	3	2	2	2	-	-	3
CO6	3	2	2	2	-	-	3

ME-207

BOARD DIPLOMA EXAMINATION, (C-21)

DME – II SEMESTER

MID SEM - I EXAMINATION ENGINEERING DRAWING - II

Time: 1 Hours]

[Total Marks: 20

PART-A

4x2=8

Instructions :

1. Answer **ALL** questions.
2. Each question carries **TWO** marks.

1. Draw the projections of a triangular prism of base side 35 mm, resting on H.P. on its base such that one of its base side is perpendicular to V.P.
2. Draw the projections of a cone of base diameter 40 mm and height 60 mm resting on H.P. on its base.
3. A cube of base side 30 mm resting on its base on H.P. such that one of its base side is making an angle of 30° to V.P. A sectional plane parallel to H.P passes through the axis at a distance of 20 mm from the base. Draw the sectional top view of the truncated cube.
4. Draw the sectional top view of the square pyramid of base side 30 mm and height 60 mm is resting on HP on its base with one of its base side is parallel to V.P. when it is cut by a horizontal section plane at a distance of 30 mm from the apex.

PART-B 2x6=12

Instructions :

1. Answer any **ALL** questions.
2. Each question carries **SIX** marks.

5. (a). Draw the projections of a pentagonal pyramid, base 30 mm edge and axis 50 mm long, having its base on the H.P. and an edge of the base parallel to the V.P. Also draw its side view.

(Or)

5. (b). A tetrahedron of 50 mm long edges is resting on the H.P. on one of its faces, with an edge of that face parallel to the V.P. Draw its projections.

6. (a) A cube of 35 mm long edges is resting on the H.P. on one of its faces with a vertical face inclined at 30° to the V.P. It is cut by a section plane parallel to the V.P. and 9 mm away from the axis and further away from the V.P. Draw its sectional front view and the top view.

(Or)

6. b) A cylinder of 40 mm diameter, 60 mm height and having its axis vertical, is cut by a section plane, perpendicular to the V.P., inclined at 45° to the H.P. and intersecting the axis 32 mm above the base. Draw its front view, sectional top view and true shape.

BOARD DIPLOMA EXAMINATION, (C-21)
DME – II SEMESTER
MID SEM- II EXAMINATION
ENGINEERING DRAWING - II

Time: 1 Hours]

[Total Marks: 20

PART-A

4x2=8

- Instructions :**
1. Answer **ALL** questions.
 2. Each question carries **TWO** marks.

1. What is the need for an auxiliary view?
2. A cube of side 30 mm placed on HP and sectioned diagonally, draw the auxiliary view of the inclined surface.
3. Draw the isometric view of a block whose orthographic projections are given below assume proper dimensions.

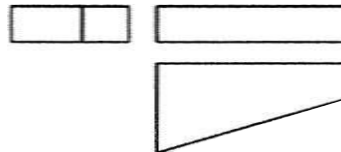

4. Draw the isometric view of a hexagonal plane of base side 30 mm when one of its side is parallel to H.P, when it is horizontal.

PART-B

2x6=12

- Instructions :**
1. Answer any **ALL** questions.
 2. Each question carries **SIX** marks.

5. (a) Draw the auxiliary view of a component given below.

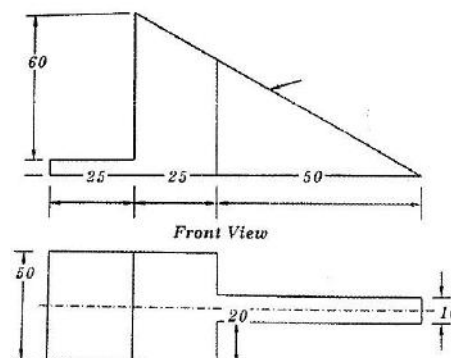

(Or)

5. (b) Draw the auxiliary view of the slopping surface of the cast iron block as shown in the figure.

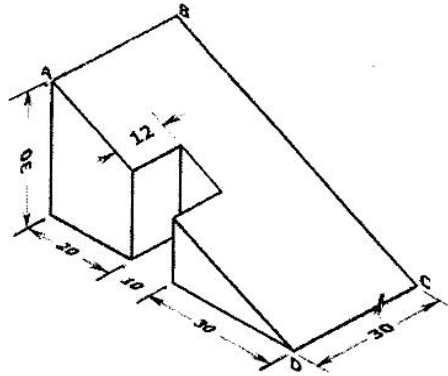

6. (a) Draw the isometric view of the block whose orthographic projections are given below by assuming proper dimensions.

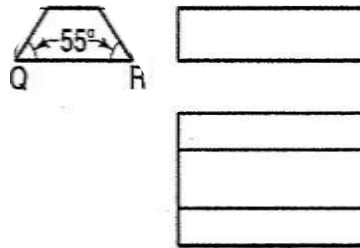

(Or)

6. (b) Draw the isometric drawing of the frustum of a cone shown in figure with proper dimensions.

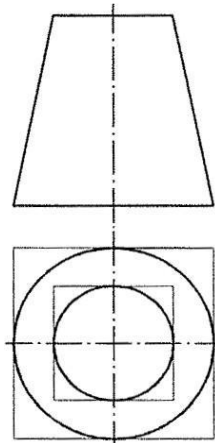

MODEL PAPER SEE
BOARD DIPLOMA EXAMINATION, (C-21)
DME-II SEMESTER END EXAMINATION
ENGINEERING DRAWING - II

Time: 2hours]

[Total Marks:40

Important Note: Wherever any question has choice, marks will be allotted only to first attempted question. **No marks will be allotted for extra questions answered.**

PART-A

- Instructions :**
1. Answer **ALL** questions.
 2. Each question carries **TWO** marks.
 3. All the dimensions are in mm.
- 8x2=16

1. Draw the projections of the cone with 30 mm height and 10 mm base circle radius, resting on H.P. on its base.
2. A cylinder with base radius 20 mm and height 60 mm resting on the ground, a 30° inclined section plane perpendicular to V.P. cuts the cylinder axis at mid-point. Draw the sectional top view of the cylinder.
3. Draw the auxiliary view of sloping surface of the object whose isometric view is

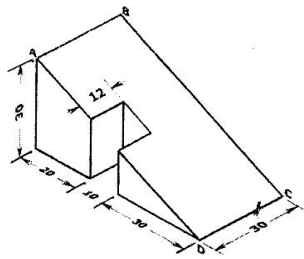

given below.

4. Draw the isometric view of a block whose orthographic views are given below by assume proper dimensions.

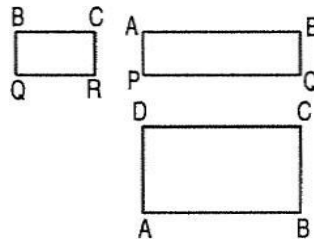

5. Develop the lateral surface of a cube of side length 30 mm.
6. Develop the lateral surface of a triangular pyramid of base side 25 mm and height 50 mm.
7. Develop the lateral surface of a cylinder of base diameter 60 mm.
8. Develop the lateral surface of a hexagonal prism of base side 25 mm and 60 mm height.

PART-B

- Instructions :**
1. Answer any **ALL** questions.
 2. Each question carries **SIX** marks.

9. a) Draw the projection of a cone of base diameter 50 mm and height 80 mm when its axis is making an angle of 45° to H.P and parallel to the V.P.

(Or)

9. b) A triangular prism, base 30 mm side and axis 50 mm long, is lying on the H.P. on one of its rectangular faces with its axis inclined at 30° to the V.P. It is cut by a horizontal section plane, at a distance of 12 mm above the ground. Draw its front view and sectional top view.

10. a) Draw the auxiliary view of sloping surface of an object shown in figure.

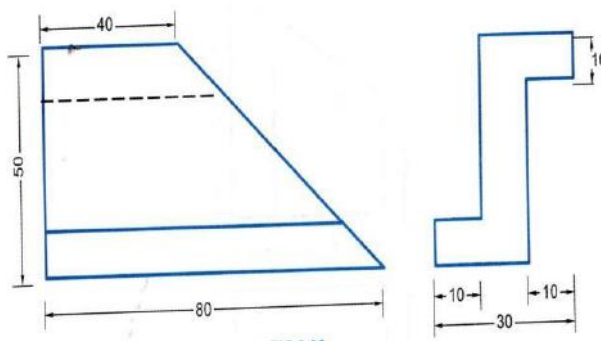

(Or)

10. b) Draw the isometric view of the block, whose orthographic views are shown in figure.

is shown.

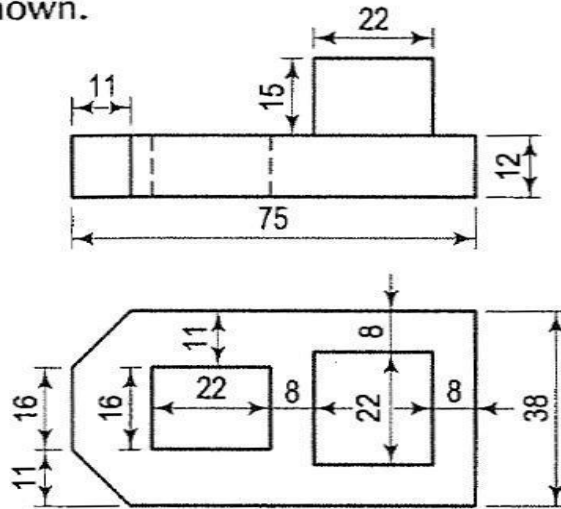

11. a) Develop the lateral surface of the truncated pentagonal prism as shown in figure.

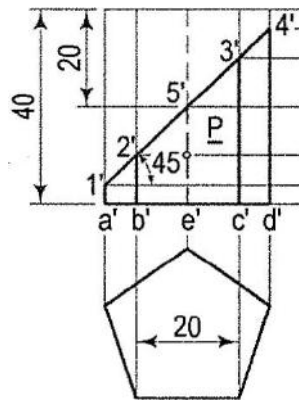

(Or)

11. b) Draw the development of a truncated cube shown in below figure.

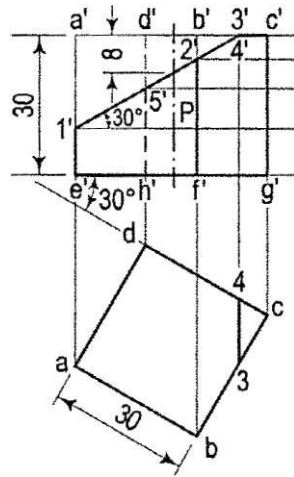

12. a) Develop of bottom portion of the truncated cylinder.

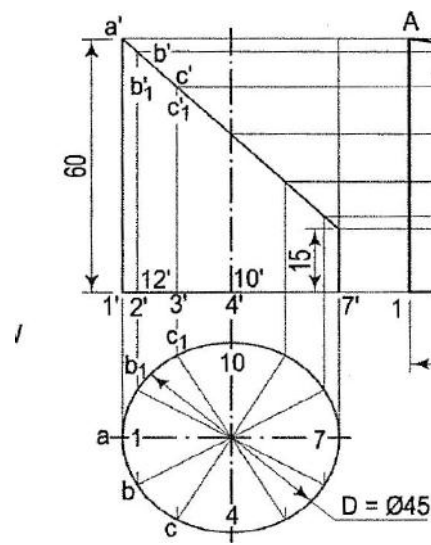

(Or)

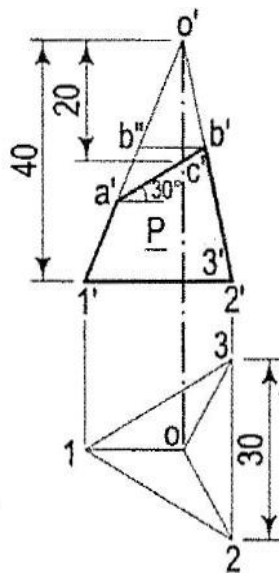

12. b) Develop the portion 'P' in the below figure.

ME-208 : CAD LAB

Course Title :	CAD Lab	Course Code	ME-208
Semester	II	Course Group	Practical
Teaching Scheme In Periods(L:T:P)	1:0:2	Credits	1.25
Methodology	Lectures+Practice	TotalContactPeriods:	45
CIE	60Marks	SEE	40Marks

Pre requisites This course requires the Basic CAD Skills and concepts of engineering drawing

COURSE OUTCOMES

At the end of the course the students will be able to :

CO	Course Outcomes (COs)
CO1	Apply basic CAD commands for entity creation, selection, and modification (lines, circles, arcs, rectangles, etc.) using absolute, relative cartesian, and polar coordinate systems.
CO2	Utilize advanced modification tools (trim, extend, stretch, fillet, chamfer) to create complex 2D shapes and leverage information retrieval tools (measure, area calculation, object properties) for accurate drawing creation.
CO3	Employ text tools for effective annotation with proper formatting and placement. Apply various dimensioning techniques (linear, angular, radial) with appropriate style control to create clear and informative drawings.
CO4	Implement layer management strategies (creation, visibility, locking, properties) to organize and control drawing elements. Utilize blocks to create reusable components and enhance drawing efficiency.
CO5	Demonstrate proficiency in basic 3D modeling techniques (extrusion, revolve, sweep, loft) to convert 2D drawings into 3D models and perform basic 3D viewing and editing tasks.
CO6	Integrate cumulative CAD skills to create a complex 2D or a simple 3D model, showcasing effective application of learned concepts in a practical scenario.

COURSE CONTENTS

UNIT 1: CAD Fundamentals (15 Periods)

Theory (3 Periods):

Introduction to CAD- Definition of Computer-Aided Drafting, Advantages of CAD, Overview of common CAD software (AutoCAD, Intelli CAD, ProG CAD, etc), Features of a CAD workstation- CAD Environment- Screen elements (drawing area, menus, toolbars), Navigating toolbars and menus- Basic Commands- Selection methods, Creating simple entities (lines, circles, arcs, rectangles, polygons), Saving and opening drawings- Coordinate Systems- Absolute coordinates, Relative cartesian coordinates, Polar coordinates.

Practice (12 Periods):

Practice with basic entity creation, Exercises using different coordinate systems, Practice with basic modification tools (move, copy, delete, mirror), Grid and snap settings configuration, Viewing tools practice (zoom, pan, scroll).

UNIT 2: Advanced Modifications & Information (10 Periods)

Theory (2 periods):

Advanced Modification Tools- Trim, Extend, Stretch, Fillet, Chamfer, Arrays- Information Retrieval Tools- Measure distance, Calculate areas, Object properties.

Practice (8 periods):

Practice creating complex shapes using advanced modification tools - Array (rectangular and polar) exercises - Practice using measure, divide, and object property tools.

UNIT 3: Text, Dimensioning, & Drawing Practice (8 Periods)

Theory (2 Periods):

Text Tools- Font styles, Text creation, Text alignment- Dimensioning- Dimensioning types (linear, angular, radial, etc), Controlling dimension styles (arrows, text format, etc).

Practice (6 Periods):

Text creation, formatting, and placement exercises - Dimensioning practice on simple 2D objects - Creating simple 2D component drawings.

UNIT 4: Layers and Blocks (5 Periods)

Theory (1 Period):

Layers- Creating layers, Layer visibility, Locking layers, Changing layer properties (color, line type, line weight), Printing on/off layers- Blocks- Concept of blocks, Creating blocks, Inserting blocks.

Practice (4 Periods):

Exercises on layer management within drawings - Practice creating and using blocks effectively.

UNIT 5: Introduction to 3D (5 Periods)

Theory (1 Period):

3D Modeling Fundamentals- Converting 2D to 3D- Extrusion, Revolve, Sweep, Loft.

Practice (4 periods):

Create basic 3D objects (boxes, cylinders, cones, spheres, wedges, tori, prisms, pyramids) - Practice viewing and basic editing in 3D.

UNIT 6: Project-Based Application(2 Periods)

Project-Based (2 Periods):

Students create a more complex 2D or simple 3D model using their cumulative skills.

RECOMMENDED BOOKS

1. Auto cad by George Omura
2. 4MCAD User Guide- IntelliCAD Technology Consortium

SPECIFIC LEARNING OUTCOMES

UNIT 1: CAD Fundamentals

1. Introduction to CAD
 - 1.1 Define Computer-Aided Drafting (CAD).
 - 1.2 Identify at least three advantages of CAD over traditional drafting methods.
 - 1.3 List three common CAD software options.
 - 1.4 Describe the basic components of a CAD workstation (monitor, input devices, etc.).
2. CAD Environment
 - 2.1 Identify the drawing area, menus, and toolbars within the CAD interface.
 - 2.2 Demonstrate how to navigate menus and toolbars.
 - 2.3 Select objects using a mouse or other input device.
3. Basic Commands
 - 3.1 Create lines, circles, arcs, rectangles, and polygons.
 - 3.2 Save a CAD drawing.
 - 3.3 Open an existing CAD drawing.
4. Coordinate Systems
 - 4.1 Define absolute, relative cartesian, and polar coordinate systems.
 - 4.2 Demonstrate how to use each coordinate system to draw basic shapes.

UNIT 2: Advanced Modifications & Information

1. Advanced Modification Tools
 - 1.1 Use the trim tool to modify object lengths.
 - 1.2 Use the extend tool to modify object lengths.
 - 1.3 Use the stretch tool to resize objects.
 - 1.4 Use the fillet tool to create rounded corners.
 - 1.5 Use the chamfer tool to create beveled edges.
2. Information Retrieval Tools
 - 2.1 Use the distance measurement tool.
 - 2.2 Use the area calculation tool.
 - 2.3 Access the object properties window.
3. Drawing Practice
 - 3.1 Create a complex shape using a combination of basic entities and modification tools.
 - 3.2 Create a rectangular array of objects.
 - 3.3 Create a polar array of objects.

UNIT 3: Text, Dimensioning & Drawing Practice

1. Text Tools
 - 1.1 Select a font style from available options.
 - 1.2 Change the size of text elements.
 - 1.3 Create a single-line text object.
 - 1.4 Create a multi-line text object.
 - 1.5 Position text within the drawing.
 - 1.6 Align text (left, center, right, justified).
2. Dimensioning

- 2.1 Add a linear dimension.
- 2.2 Add an angular dimension.
- 2.3 Add a radial dimension.
- 2.4 Modify the appearance of dimension arrows.
- 2.5 Modify the format of dimension text.
- 3. Drawing Practice
 - 3.1 Create a simple 2D component drawing.
 - 3.2 Add appropriate text annotations to the drawing.
 - 3.3 Add necessary dimensions to fully define the component.

UNIT 4: Layers and Blocks

- 1. Layers
 - 1.1 Explain the purpose of layers in CAD drawings.
 - 1.2 Create a new layer.
 - 1.3 Assign a name to a layer.
 - 1.4 Change the color of a layer.
 - 1.5 Change the line type of a layer.
 - 1.6 Change the line weight of a layer.
 - 1.7 Set a layer as the current active layer.
 - 1.8 Turn layer visibility on or off.
 - 1.9 Freeze or thaw a layer.
 - 1.10 Lock or unlock a layer.
- 2. Blocks
 - 2.1 Define the concept of a block in CAD.
 - 2.2 Explain the advantages of using blocks.
 - 2.3 Create a block from existing geometry.
 - 2.4 Insert a block instance into a drawing.
 - 2.5 Move a block instance.
 - 2.6 Rotate a block instance.
 - 2.7 Scale a block instance.
 - 2.8 Explode a block instance.

UNIT 5: Introduction to 3D Modeling

- 1. 3D Modeling Fundamentals
 - 1.1 Explain the basic difference between 2D and 3D CAD modeling.
 - 1.2 Describe the extrusion method of creating 3D objects.
 - 1.3 Describe the revolve method of creating 3D objects.
- 2. 3D Creation
 - 2.1 Create a basic box shape using extrusion.
 - 2.2 Create a basic cylinder shape using revolve.
 - 2.3 Create other basic 3D shapes (cone, sphere, wedge, etc.)
- 3. 3D Navigation & Editing
 - 3.1 Use orbit, pan, and zoom tools to view a 3D model.
 - 3.2 Move a 3D object.
 - 3.3 Copy a 3D object.

UNIT 6: Project-Based Application

1. Planning

1.1 Choose a project that aligns with the skills learned (more complex 2D drawing or simple 3D model).

1.2 Sketch or outline a basic plan for the project.

1.3 Identify the CAD tools and techniques needed for the project.

2. Execution

2.1 Create a new CAD drawing with appropriate settings.

2.2 Apply drawing commands to build the chosen object or component.

2.3 Utilize layers effectively to organize the drawing.

2.4 Use blocks where appropriate to increase efficiency.

2.5 Add necessary text and dimensions, ensuring clarity and accuracy.

2.6 Employ 3D modeling techniques (if chosen for the project).

3. Problem-Solving

3.1 Troubleshoot any issues encountered during the creation process.

3.2 Reference help resources or seek assistance if needed.

3.3 Adapt the approach as needed to achieve the desired outcome of the project.

4. Presentation

4.1 Save the final project in an appropriate format.

4.2 Prepare the project for presentation (This might include printing, creating screenshots, or preparing a 3D rendering).

Unit	Exercise	Key Components
Unit 1	Basic Shape Creation: Create drawings with lines, circles, arcs, rectangles, and polygons	Coordinate systems, selection tools, basic drawing commands
	Entity Modification: Modify existing shapes using editing tools	Move, copy, trim, extend, offset
	File Management Save, open, and close drawings	File formats, project organization
Unit 2	Advanced Modification: Create a more complex shape by combining basic entities and advanced tools	Trim, extend, stretch, fillet, chamfer, arrays
	Measuring & Analysis: Calculate the area, perimeter of shapes on a drawing	Measurement tools, object properties window
Unit 3	Component Drawing: Create a detailed 2D drawing of a mechanical part	Text tools, dimensioning, dimension styles, drawing conventions
Unit 4	Layer & Block Usage: Create a drawing with multiple components, organizing them on separate layers	Layer creation, properties, visibility, blocks (create, insert)
Unit 5	3D Fundamentals: Convert a 2D component drawing into a simple 3D model	Extrusion, revolve, sweep, loft, basic 3D navigation
Unit 6	Project Application: Design and execute a more complex 2D or simple 3D model project	Cumulative CAD skills, planning, problem-solving, presentation

Course Outcome		Cognizant Level	Linked PO	Teaching Hours
CO1	Apply basic CAD commands for entity creation, selection, and modification (lines, circles, arcs, rectangles, etc.) using absolute, relative cartesian, and polar coordinate systems.	U/A	1,2,3,4,5,6,7	15
CO2	Utilize advanced modification tools (trim, extend, stretch, fillet, chamfer) to create complex 2D shapes and leverage information retrieval tools (measure, area calculation, object properties) for accurate drawing creation.	U/A	1,2,3,4,5,6,7	10
CO3	Employ text tools for effective annotation with proper formatting and placement. Apply various dimensioning techniques (linear, angular, radial) with appropriate style control to create clear and informative drawings.	U/A	1,2,3,4,5,6,7	8
CO4	Implement layer management strategies (creation, visibility, locking, properties) to organize and control drawing elements. Utilize blocks to create reusable components and enhance drawing efficiency.	U/A	1,2,3,4,5,6,7	5
CO5	Demonstrate proficiency in basic 3D modeling techniques (extrusion, revolve, sweep, loft) to convert 2D drawings into 3D models and perform basic 3D viewing and editing tasks.	U/A	1,2,3,4,5,6,7	5
CO6	Integrate cumulative CAD skills to create a complex 2D or a simple 3D model, showcasing effective application of learned concepts in a practical scenario.	A	1,3,4,5,6,7	2

CO-POMATRIX

CO/PO	PO1	PO2	PO3	PO4	PO5	PO6	PO7
CO1	1.5	3	3	3	1.5	3	3
CO2	1.5	1.5	3	3	1.5	3	3
CO3	2	1.5	3	1	2	3	1
CO4	1.5	3	3	3	1.5	3	3
CO5	3	1.5	1.5	1.5	3	3	1.5
CO6	1.5	0	3	3	1.5	1.5	3

ME-208- CAD Lab
Lab MODEL PAPER FORM ID
-I(CIE)

TIME: 2hr

Marks: 20M

PART-A

NOTE: Answer all questions

4 X 2 = 8marks

1. Draw a square of 50x50mm by using any CAD software.
2. Draw an equilateral triangle of 50mm side by using any CAD software.
3. Draw a line of 10mm and divide it into four equal parts.
4. Draw a pentagon of side 60mm and calculate its area by using any CAD software.

PART-B

NOTE: Answer any one question

1 X 12 = 12marks

5. Draw the following using any CAD software and add dimensioning.

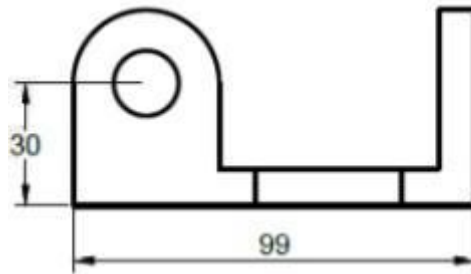

6. Draw the following using any CAD software and add dimensioning.

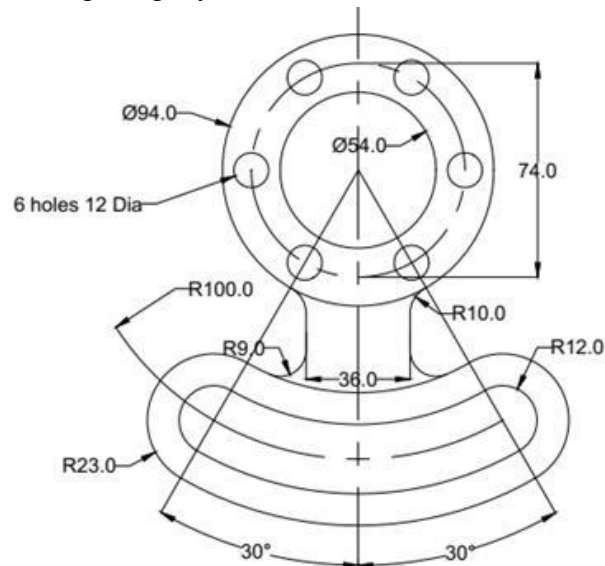

ME-208- CAD Lab
MODEL PAPER FORM ID-II(CIE)

TIME: 2hr

Marks: 20M

PART-A

NOTE: Answer all questions

4 X 2 = 8marks

1. Write text "CADLab" with Calibri font style and font size 10 by using any CAD software.
2. Draw a line of 10mm, divide it into four equal parts and add continuous dimensions to divided line.
3. Create four layers, name the layers and assign different properties like line color, line type, line weight to different layers.
4. Write the procedure to create a block.

PART-B

NOTE: Answer any one questions

1 X 12 = 12marks

5. Draw the following using Layers. Use different layers to different line types, text, dimension and main figure.

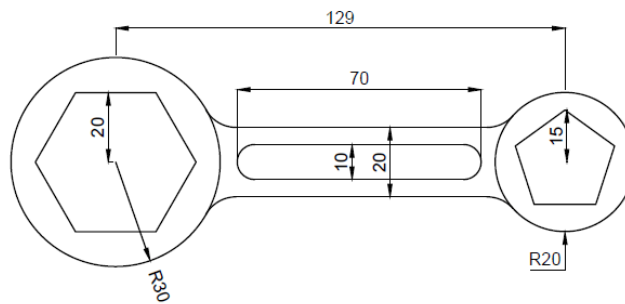

6. Draw the following using Layers. Use different layers to different line types, text, dimension and main figure.

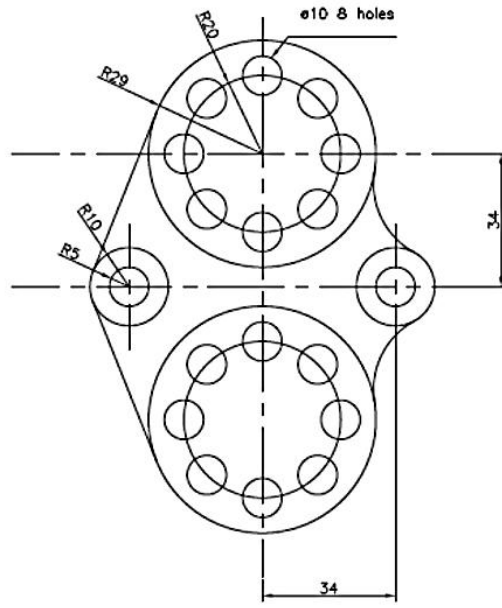

ME-208- CAD Lab
MODEL PAPER FORSEE

TIME:3hr

Marks:40M

PART-A

NOTE: Answer all questions

4X 4 =16marks.

1. Draw a hexagon of 60mm side and add dimensions to it.
2. Create a rectangular array of 10mm diameter circles in 4 rows,, 4 columns with 20mm space between each row and column.
3. Create four layers, name the layers and assign different properties like line color, line type, line weight to different layers.
4. Write the procedure to create and insert a block.

PART-B

NOTE: Answer any one questions

1X 24 =24marks

5. (a) Draw the following 3D object in CAD software. 20+4marks
(b) List the commands in sequence and also write the procedure

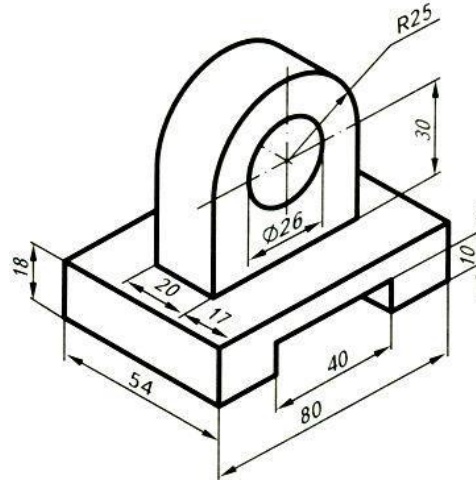

6. (a) Draw the following 3D object in CAD software. 20+4marks
(b) List the commands in sequence and also write the procedure

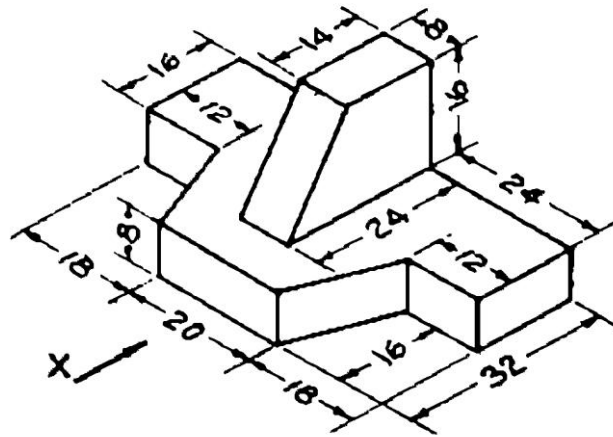

SC-209: APPLIED SCIENCE LAB

Course Title	Applied Science Lab	Course Code	SC-209
Semester	II Semester	Course Group	Practical
Teaching Scheme in Periods (L:T:P)	15:0:30	Credits	1.25
Type of course	Lecture + Practical	Total Contact Periods	45
CIE	60 Marks	SEE	40 Marks

SC-209 (A) Physics Lab

Pre requisites:

This course requires the basic knowledge of Science and Mathematics.

Course Outcomes

Upon completion of the course, the student shall be able to

CO1	Determine the value of acceleration due to gravity using simple pendulum and verify with L-T ² graph.
CO2	Determine the velocity of sound in air at room temperature and calculate velocity of sound at 0 ⁰ C.
CO3	Draw magnetic lines of force, locate neutral points and calculate magnetic moment of a bar magnet.
CO4	Determine the specific resistance of given wire using meter bridge.
CO5	Determine the refractive index of a solid using travelling microscope
CO6	Develop V-I characteristics of Photocell (Demonstration only)

	Basic and Discipline Specific Knowledge	Problem Analysis	Design/Development of Solutions	Engineering Tools, Experimentation and Testing	Engineering Practices Engineering Practices for Society, Sustainability and Environment	Project Management	Lifelong Learning	Linked PO
CO	PO1	PO2	PO3	PO4	PO5	PO6	PO 7	
CO1	3					1	1	1,6,7
CO2	3					1	1	1,6,7
CO3	3					1	3	1,6,7
CO4	3					1	3	1,6,7
CO5	3					1	3	1,6,7

Learning outcomes

On successful completion of the course, the student will have ability to:

1. Determine the value of acceleration due to gravity using simple pendulum and verify with $L-T^2$ graph.
2. Determine the velocity of sound in air at room temperature and calculate velocity of sound at 00 C.
3. Draw magnetic lines of force, locate neutral points and calculate magnetic moment of a bar magnet. Determine the specific resistance of given wire using meter bridge.
4. Determine the refractive index of a solid using travelling microscope.
5. V-I characteristics of Photocell (Demonstration only)

Course Delivery:

The course will be delivered through lectures, class room interaction, group discussions, graded exercises, demonstration and practice.

Tutorial: 1 Period/Experiment:

1. Introduction to Physics practical and its importance, safety precautions in maintenance of equipment in the laboratory.
2. Maintenance of apparatus and equipment.
3. Follow of Do's and Don'ts.
4. Maintenance of data in manual and record book.
5. Write the procedure of the experiment before the commencement of each experiment.
6. Strictly following of instructions given from time to time by the lecturer-in-charge.
7. Demonstration of each experiment by the lecturer in charge.

Conduction of experiments: 2 periods/Experiment.

Student must perform experiment individually under the supervision of the lecturer-in charge.

EXAMINATION & EXPERIMENTS		
S.NO	EXAMINATION	EXPERIMENTS
1	MIDSEM-I	EXPERIMENT NO 1 & 2
2	MIDSEM-II	EXPERIMENT NO 3 & 4
3	SEMESTER END EXAMINATION	EXPERIMENT NO 1,2,3,4 and 5

Scheme of Valuation of SEE		
S.No	Particulars	Marks
1.	Objective/Aim	01
2.	Apparatus/Equipment	02
3.	Observations	02
4.	Principle including formula	02
5.	Experiment (Tabular form, readings, etc)	05
6.	Calculation and Result	05
7.	Viva Voce	03
	Total	20

References:

1. Intermediate Physics lab manual – Telugu Academy
2. Laboratory manual for class XI and XII – NCERT

SC-209 (B) Chemistry Lab

Prerequisite: Knowledge of basic concepts of Chemistry of Secondary Education

Course Objectives:

To provide practical knowledge about the basics of volumetric analysis of chemical compounds

Course Outcomes:

On successful completion of the course, the student will have ability to attain the following COs

Course Outcome	
CO1	Determine the molarity of potassium permanganate solution.
CO2	Estimate the amount of the Mohr's salt in the given solution.
CO3	Determine of acidic impurities present in water samples.
CO4	Determine of alkaline impurities present in water samples.
CO5	Estimate the amount of the chlorides in the water sample.

CO-PO Matrix:

CO	PO1	PO2	PO3	PO4	PO5	PO6	PO7
CO1	3	-	-	-	-	1	1
CO2	3	-	-	-	-	1	1
CO3	3	-	-	-	2	1	1
CO4	3	-	-		2	1	1
CO5	3	-	-	-	2	1	1

Course Delivery:

The course will be delivered through lectures, classroom interaction, group discussion, demonstration and practical.

Conduction of experiments: Lecture 1 period + Experiment 2 periods.

Student must conduct experiment individually under the supervision of the staff-in-charge.

Lecture and Demonstration: 1 Period

1. Introduction of chemistry practical and its importance, safety precautions in maintenance of cleanliness and orderliness of chemicals in the laboratory.
2. Maintenance of apparatus and equipment.
3. Follow of Do's and Don'ts.
4. Maintenance of data in record book.
5. Write the procedure of the experiment before the commencement of each experiment.
6. Strict following of instructions given from time to time by the staff-in-charge.
7. Demonstration of each experiment by the staff-in-charge.

Course content

Volumetric Analysis: (22.5 Periods) Volumetric Analysis by Titrimetric Method:-

Volumetric Analysis - Titration – Standard solutions - Concentration of solutions - Indicators – Self indicator - Acid base indicators - Selection of indicators - Endpoint of titration - Neutralization.

List of experiments:

1. Determination of molarity of KMnO_4 by using standard oxalic acid solution
2. Estimation of Mohr's salt by using standard KMnO_4 solution.
3. Determination of acidity of water sample by using standard NaOH solution.
4. Determination of alkalinity of water sample by using standard H_2SO_4 solution.
5. Estimation of chloride content present in water sample by using standard AgNO_3 solution.

Specific Learning Outcomes

Upon completion of the course, the student will have ability to

1. Determine the molarity of KMnO_4 by using 0.1 M oxalic acid solution
2. Estimate Mohr's salt by using 0.05 M potassium permanganate solution.
3. Determine the partial and total acidity of water sample by using 0.02 N NaOH solution.
4. Determine the partial and total alkalinity of water sample by using 0.02 N H_2SO_4 solution.
5. Estimate the chloride content present in water sample by using 0.0141 N AgNO_3 solution.

Reference Books:

1. Vogel's Inorganic Qualitative and Quantitative Analysis.
2. Practical chemistry by O.P. Pande & others.
3. Qualitative and quantitative analysis by Alex.

EXAMINATION & EXPERIMENTS		
S.NO	EXAMINATION	EXPERIMENTS
1	MIDSEM-I	Experiment No 1 & 2
2	MIDSEM-II	Experiment No 3 & 4
3	SEMESTER END EXAMINATION	Experiment No 1, 2, 3, 4 and 5

Scheme of Valuation for SEE		
Sl.No.	Particulars	Marks
1	Identification of apparatus/equipment/chemical compounds/tools/etc.	2
2	Writing Principle and Procedure	5
3	Experiment and Observations	6
4	Calculation and Results	4
5	Viva-voce	3
Total		20

BOARD DIPLOMA EXAMINATION, (C-24)
SECOND SEMESTER EXAMINATION
MIDSEM – I
SC-209: APPLIED SCIENCE LAB

TIME: 1 Hour

TOTAL MARKS: 20

Instructions: (1) Answer both PART-A AND PART-B on separate answer sheets.
(2) Each question carries **TEN** marks.

PART-A (PHYSICS LAB)

Perform ONE experiment allotted by the examiner.

1 x 10 = 10

1. Determine the value of acceleration due to gravity using L-T² graph.
2. Determine the value of acceleration due to gravity using simple pendulum.
3. Determine the velocity of sound in air at room temperature.
4. Determine the velocity of sound in air at room temperature and calculate velocity of sound at 0° C.

PART-B (CHEMISTRY LAB)

Perform ONE experiment allotted by the examiner.

1 x 10 = 10

1. Determine the molarity of KMnO₄ solution by using 0.1M oxalic acid.
2. Estimate the amount of Mohr's salt present in the given 500 ml of solution by using 0.02M Potassium permanganate solution
3. Estimate the amount of Mohr's salt present in the given 750 ml of solution by using 0.02M Potassium permanganate solution.

BOARD DIPLOMA EXAMINATION, (C-24)
SECOND SEMESTER EXAMINATION
MIDSEM – II
SC-209: APPLIED SCIENCE LAB

TIME: 1 Hour

TOTAL MARKS: 20

Instructions: (1) Answer both PART-A AND PART-B on separate answer sheets.
(2) Each question carries **TEN** marks.

PART-A (PHYSICS LAB)

Perform ONE experiment allotted by the examiner.

1 x 10 = 10

1. Draw magnetic lines of force and calculate magnetic moment of a bar magnet.
2. Draw magnetic lines of force and locate neutral points of a bar magnet.
3. Determine the specific resistance of given wire using meter bridge.
4. Determine the resistance of given wire using meter bridge.

PART-B (CHEMISTRY LAB)

Perform ONE experiment allotted by the examiner.

1 x 10 = 10

1. Determine the partial acidity of water sample by using 0.02N NaOH solution.
2. Determine the total acidity of water sample by using 0.02N NaOH solution
3. Determine the partial alkalinity of water sample by using 0.02N H₂SO₄ solution.
4. Determine the total alkalinity of water sample by using 0.02N H₂SO₄ solution

BOARD DIPLOMA EXAMINATION, (C-24)
SECOND SEMESTER END EXAMINATION
SC-209 - APPLIED SCIENCE LAB

Time: 2 Hours]

[Total Marks: 40

Instructions: (1) Answer both PART-A AND PART-B on separate answer sheets.

(2) Each question carries **TWENTY** marks.

PART-A (PHYSICS LAB)

Perform ONE experiment allotted by the examiner.

1 x 20 = 20

1. Determine the value of acceleration due to gravity using L-T² graph.
2. Determine the value of acceleration due to gravity using simple pendulum.
3. Determine the velocity of sound in air at room temperature.
4. Determine the velocity of sound in air at room temperature and calculate velocity of sound at 0° C.
5. Draw magnetic lines of force and calculate magnetic moment of a bar magnet.
6. Draw magnetic lines of force and locate neutral points of a bar magnet.
7. Determine the specific resistance of given wire using meter bridge.
8. Determine the resistance of given wire using meter bridge.
9. Determine the refractive index of a solid using travelling microscope.

PART-B (CHEMISTRY LAB)

Perform ONE experiment allotted by the examiner.

1 x 20 = 20

1. Determine the molarity of KMnO₄ solution by using 0.1M oxalic acid.
2. Estimate the amount of Mohr's salt present in the given one litre of solution by using 0.02M KMnO₄ solution.
3. Determine the partial acidity of water sample by using 0.02N NaOH solution.
4. Determine the total acidity of water sample by using 0.02N NaOH solution.
5. Determine the partial alkalinity of water sample by using 0.02N H₂SO₄ solution.
6. Determine the total alkalinity of water sample by using 0.02N H₂SO₄ solution.
7. Estimate the chloride content present in water sample by using 0.0141N AgNO₃ solution.

CS-210: PROGRAMMING IN 'C' LAB

Course Title	Programming in C Lab	Course Code	CS-210
Semester	II Semester	Course Group	Practical
Teaching Scheme in Periods(L:T:P)	1:0:2	Credits	1.25
Methodology	Lecture + Practical	Total Contact Hours:	45
CIE	60Marks	SEE	40Marks

Prerequisites

Basic knowledge of Mathematics, Logical, Reasoning and IT skills.

Course Content and Blue Print of Marks for SEE

Unit No	Unit name	Hours/ Periods	Marks for SEE			Marks weightage	%Weightage
			Coding	Execution	Viva		
1	Programming in C Lab	45	20	10	10	40	100
	Total	45	40			40	100

Course Outcomes

On successful completion of the course, the students will be able to

CO'S	Description
CO1	Use the concepts of algorithm and flow chart for developing programs in C language.
CO2	Use variables, constants, data types, operators and Input / Output functions in programs
CO3	Apply decision making and looping concepts for developing programs in C language
CO4	Implement the concepts of arrays and structures for a given problem
CO5	Illustrate the use of functions in developing modular programming
CO6	Illustrate the usage of structures and unions.

Course Content

Unit Number	Unit Name	Periods
1	Programming Methodology and Introduction to C Language	2
2	Understand Constants, Variables and Data types in C and Understand Operators and Expressions in C	4
3	DecisionmakingandLoopingstatements	9
4	ArraysandStrings	10
5	User Defined functions	10
6	Structure,union	10
	Total	45

Recommended Books

1. Let Us C -- Yeshwanth Kanetkar BPB Publications
2. Programming in ANSI C -- E. Balaguruswamy Tata McGraw Hill
3. Programming with C -- Gottfried Schaum's outline
4. C The complete Reference -- Herbert Schildt Tata McGraw Hill

Suggested E-learning references

13. https://www.w3schools.com/c/c_intro.php?external_link=true
14. <https://www.geeksforgeeks.org/c-programming-language/>
15. <https://www.programiz.com/c-programming>
16. <https://www.javatpoint.com/c-programming-language-tutorial>
17. <https://www.freecodecamp.org/news/the-c-programming-handbook-for-beginners/>
18. <https://www.tutorialspoint.com/cprogramming/index.htm>
19. <https://www.codecademy.com/catalog/language/c>
20. <https://www.codechef.com/learn/course/c>
21. <https://archive.nptel.ac.in/courses/106/104/106104128/>
22. <https://www.youtube.com/watch?v=3QiItmIWmOM>
23. <https://www.digimat.in/nptel/courses/video/106105171/L01.html>
24. <https://www.digimat.in/nptel/courses/video/106105171/L07.html>

Suggested Learning Outcomes

Upon completion of the course, the student shall be able to

List of Exercises:

1. Write an algorithm to compute whether a given number is even or odd.
2. Write a algorithm to check whether a given year is leap year.
3. Draw a flowchart to identify whether the given number is a “BUZZ” number or not.
4. Write and execute a C program to compute number of months, number of remaining weeks and number of remaining days, given number of days. (**hint : Input:** 265 days
Output: 8 months, 3 weeks,4days)
5. Write and execute a C program to compute Lateral surface area, Total surface area and volume of a cuboid given length, breadth and height.
6. Write and execute a C program to evaluate an expression using operator precedence and associativity rule.
(hint: $a+b/c*d - (e * (f-z)\%k$)
7. Write and execute a C program to display the following pattern using for loop given n rows
(hint n=4).
1
1 2
1 2 3
1 2 3 4
8. Write and execute a C program to reverse a 4 digit number.
9. Write and execute a C program to print all the prime numbers from 2 to n.
10. Write and execute a C program to read two matrices to perform matrix addition.
11. Write and execute a C program to perform matrix multiplication.
12. a. Write and execute a C program to check whether the given string is palindrome or not.
b. Write and execute a C program to read a line of text and display the vowels and consonants.
13. Write and execute a C program to compute the following series using functions
 $1+ x+(x^2/2!) +(x^3/3!) +\dots\dots\dots+(x^n/n!)$
14. Write and execute a C program to compute the sum of first n natural numbers using recursion.
15. Write and execute a C program on” TOWERS OF HANOI PROBLEM“ using recursion.
16. Write and execute a C program to read two integers and compute sum, difference, product, quotient using “functions with arguments and with return values”.
17. Consider and execute a structure with the following structure members
a.Student name b. PIN c.subject1 marks d. subject2 marks e. subject3 marks
Write and execute a Program to compute individual subject total, individual student marks

total for n number of students.

18. Write and execute a c program to read, retrieve, and display the members of a union.

Suggested Student Activities

1. Slip test on C snippets
2. Lab Slip test to execute a random program beyond the given list of exercises

CO-PO Mapping Matrix

	Basic and Discipline Specific Knowledge	Problem Analysis	Design/Development of Solutions	Engineering Tools, Experimentation and Testing	Engineering Practices for Society, Sustainability and Environment	Project Management	Lifelong Learning	Linked PO
CO	PO1	PO2	PO3	PO4	PO5	PO6	PO 7	
CO1	1	1	1			2	1	1,2,3,6,7
CO2	1						1	1,7
CO3	1	2	1	2	1	2	1	1,2,3,4,5,6,7
CO4	1	1	1	1	2	1	1	1,2,3,4,5,6,7
CO5	2	2	1	3	1	2	1	1,2,3,4,5,6,7
CO6	1	1	1			1	1	1,2,3,6,7